

## **APPENDIX B**

# **ENVIRONMENTAL CONSTRUCTION STANDARDS**

**Appendix B has the following NiSource Environmental construction Standards:**

- Attachment B1 – Columbia Gas Transmission Corporation Environmental Construction Standards – 2008
- Attachment B2 – Columbia Gas Transmission Corporation Environmental Construction Standards – Virginia Projects - 2008
- Attachment B3 – Columbia Gulf Transmission Company Environmental Construction Standards – 2008

**Attachment B1 – Columbia Gas Transmission Corporation  
Environmental Construction Standards – 2008**

**Attachment B2 – Columbia Gas Transmission Corporation  
Environmental Construction Standards – Virginia Projects - 2008**

**Attachment B3 – Columbia Gulf Transmission Company  
Environmental Construction Standards – 2008**



# **ENVIRONMENTAL CONSTRUCTION STANDARDS**

January 2008

---

Columbia Gas Transmission  
Charleston, West Virginia

## TABLE OF CONTENTS

I.	INTRODUCTION.....	1
II.	UPLAND CONSTRUCTION.....	2
A.	General.....	2
B.	Right-of-Way Width .....	2
C.	Clearing .....	3
1.	Wood Products .....	3
2.	Brush .....	3
3.	Fence Crossings.....	4
D.	Grading.....	4
1.	Tree Stump and Rock Removal and Disposal.....	4
2.	Topsoil Conservation .....	5
3.	Erosion Control Devices .....	5
4.	Temporary Road Entrances.....	6
E.	Access Roads .....	6
F.	Residential Areas .....	7
G.	Trenching .....	7
1.	Trenching Specifications .....	7
2.	Blasting.....	8
3.	Temporary Construction Access Over the Trenchline.....	8
4.	Drainage Tile and Irrigation Facilities .....	9
H.	Backfilling Specifications .....	9
I.	Final Grading, Restoration and Stabilization .....	9
1.	Final Grading .....	10
2.	Soil Compaction Testing.....	11
3.	Restoration .....	11
4.	Temporary Stabilization.....	12
5.	Restoring Man-Made Structures.....	13
6.	Off-Road Vehicle (ORV) Control.....	13
J.	Noise Impact Mitigation and Dust Control .....	14
K.	Hydrostatic Testing.....	14
III.	STREAM AND WETLAND CROSSINGS.....	15
A.	Stream Crossings.....	15
1.	General.....	15
2.	Crossing Techniques.....	16
3.	Clearing .....	17
4.	Grading.....	17
5.	Trenching.....	18
6.	Blasting.....	19
7.	Backfilling .....	19
8.	Restoration .....	19
B.	Wetland Crossings .....	21

1.	General.....	21
2.	Crossing Techniques.....	21
3.	Clearing.....	22
4.	Grading.....	22
5.	Trenching.....	23
6.	Blasting.....	23
7.	Backfilling.....	23
8.	Restoration.....	24
IV.	SPILL PREVENTION, CONTAINMENT AND CONTROL.....	24
A.	General.....	24
B.	Spill Cleanup.....	26
V.	MAINTENANCE.....	27
A.	General.....	27
B.	Upland Areas.....	27
C.	Waterbodies, Wetlands, And Environmentally Sensitive Areas.....	28
VI.	ENVIRONMENTAL CONSTRUCTION MANAGEMENT AND INSPECTION.....	29
A.	General.....	29
B.	Environmental Inspector.....	29
C.	Environmental Training.....	31
D.	Contractor's Environmental Compliance Specialist (Environmental Foreman) ...	31
E.	Environmental Construction Management.....	31
F.	Environmental Variances.....	32
VII.	EMERGENCY CONSTRUCTION.....	32
VIII.	DEFINITION OF TERMS*.....	33
IX.	TABLES.....	36
X.	FIGURES.....	37
A.	Figure 1 – Typical Upland Pipeline Construction Sequence.....	37
B.	Figure 2 – Typical 75ft. Construction Right-of-Way.....	38
C.	Figure 3 – Typical 50ft. Construction Right-of-Way.....	39
D.	Figure 4 – Temporary Construction Gate.....	40
E.	Figure 5 – Typical Soil Conservation.....	41
F.	Figure 6A - Interceptor Diversions/Slope Breakers.....	42
G.	Figure 6B – Interceptor Diversions.....	43
H.	Figure 7 – Sediment Filter Device Silt Fencing.....	44
I.	Figure 8 – Sediment Filter Device Staked Bales.....	45
J.	Figure 9 – Temporary Road Entrance Rock Pads.....	46
K.	Figure 10 – Temporary Road Entrance Terra-Mats.....	47



L.	Figure 11 – Temporary Road Entrance Board Road.....	48
M.	Figure 12 – Typical Erosion Control Measures at Road Crossings.....	49
N.	Figure 13 – Trenchline Barriers and Breakers .....	50
O.	Figure 14A – Sediment Trap .....	51
P.	Figure 14B – Filter Bag .....	52
Q.	Figure 15 – Field Tile Replacement Methods.....	53
R.	Figure 16 – Erosion Control Blanket .....	54
S.	Figure 17 – Typical Stream Crossing Intermittent Streams.....	55
T.	Figure 18 – Typical Stream Crossing Dry-Ditch .....	56
U.	Figure 19 – Typical Stream Crossing Dam and Pump .....	57
V.	Figure 20 – Typical Stream Crossing Wet-Ditch .....	58
W.	Figure 21 – Temporary Equipment Crossing Culvert and Stone.....	59
X.	Figure 22 – Temporary Equipment Crossing Equipment Pads .....	60
Y.	Figure 23 – Typical Wetland Crossing .....	61
Z.	Figure 24 – ROW Maintenance Perennial Streams .....	62

## I. INTRODUCTION

Columbia is committed to complying with the applicable environmental rules and regulations of federal, state, and local governments. Columbia's goal is to meet these requirements in the pursuit of a cleaner, safer environment for future operations.

Recognizing this goal, it is Columbia's policy that all construction, operation and maintenance activities be conducted in a safe manner that minimizes impacts on stream and wetland ecosystems, wildlife habitat, cultural resources and the human environment. To this end, Columbia has prepared these Environmental Construction Standards (ECS). The ECS provides the minimum requirements to be applied to all construction, operation and maintenance activities.

The general objective of this ECS is to provide Columbia personnel and Columbia's contractors with instructional information, complete with a practical approach to environmental concerns, which can arise before, during and after facility construction. More specific objectives include:

- minimize impacts to environmentally sensitive areas;
- use the minimum land required for safe and efficient construction, operation, and maintenance of the facilities;
- prevent erosion and sedimentation during construction; and
- complete construction in a safe and timely manner.

Words and/or phrases which have special meaning (shown in **bold** at first occurrence in text) and acronyms have been defined in Definition of Terms Section VIII.

The intent of the ECS is to confine project-related disturbance to the identified **construction work areas** and to minimize erosion and enhance revegetation in those areas. Any project-related ground disturbance (including erosion) outside of these areas is subject to compliance with all applicable survey<sup>1</sup> (see superscript note on Page 32) and mitigation requirements.

The ECS is focused primarily on pipeline related construction, operation, and maintenance. However, it can be equally applied to all Columbia facilities, for example, storage facilities including well locations, compressor stations, horizontal directional drill locations and measurement/regulation stations. This ECS shall be used as the base document from which Columbia will build individual project-specific Environmental Management and Construction Plans (EM&CP) as called for in Columbia's Policy and Procedure, Plan 120-10. The EM&CP may include written recommendations from the local soil conservation authorities or land management agencies for both temporary and permanent erosion control and revegetation specifications. Federal, State and local agencies having regulations more stringent than this ECS shall supercede<sup>2</sup> (see superscript note [2](#)).

## II. UPLAND CONSTRUCTION

### A. General

This chapter describes typical upland pipeline construction.

The upland pipeline construction spread operates as a moving assembly line performing specialized procedures in an efficient, planned sequence. Figure 1 presents this typical upland pipeline construction sequence. In addition, special construction crews install and alter fences, bore under roads and railroads, install stream and **wetland** crossings that are not done by conventional upland techniques, and construct valve settings and meter/regulator stations.

While construction work is on going, the construction work area will be kept clean of all rubbish and debris resulting from the work. Non-hazardous materials and waste shall be disposed of in an approved landfill. Hazardous waste shall be disposed of in accordance with Columbia policies (Plan 120.03 and 120.04) and federal, state and local regulations.

### B. Right-of-Way Width

For 14-inch or larger diameter pipelines on new alignments, Columbia typically utilizes a 50-foot wide permanent right-of-way (ROW) and a 25-foot wide temporary construction ROW as illustrated in Figure 2. After the construction work area is restored, the temporary work areas are allowed to revert to its previous uses. The permanent ROW is maintained as Columbia's permanent ROW for the facility. Figure 2 also illustrates the typical pipeline construction work area when paralleling existing facilities.

In addition, there may be instances where extra work areas are needed for topsoil conservation, side hill construction, equipment staging, pipe and material storage, borrow and disposal areas, temporary and permanent access, and related construction activities. Such areas will be identified in the project plans and will undergo all required environmental and cultural resources reviews prior to use. In contrast, pipelines may be constructed through confined areas such as extremely steep and narrow ridges. Alternate construction methods may be required in narrow construction work area situations to safeguard workers, equipment, the pipeline, and the environment.

For 12-inch and smaller diameter pipelines, a 50-foot wide ROW is typically used due to a narrower trench and the use of smaller equipment. The typical 50-foot ROW is illustrated in Figure 3. In addition, there may be areas where extra construction work areas are needed as described above.

For non-pipeline construction activities, such as storage well locations and station projects, the construction work area and permanent ROW may vary and can be dependent on property lease, property owner agreements, and/or local topography. For example, the construction work area for a typical storage well is 200 feet by 200 feet and the permanent ROW is a 300-foot radius around the well.

## C. Clearing

The construction work area is cleared to the width specified in the ROW agreements or EM&CP, whichever is less, during clearing operations, all brush and trees will be felled into the construction work area to prevent off-construction work area damage to trees and structures.

The clearing crew and related equipment and equipment necessary for installation of equipment crossings will be permitted a single pass through streams prior to equipment crossing installations unless the stream is a **high quality stream** or designated as an **exceptional value water**. Federal, State and local agencies having regulations more stringent than this shall supercede<sup>2</sup> (see superscript note 2).

Should substantial soil disturbance take place during clearing install temporary erosion and sedimentation controls as described in section D-3.

### 1. Wood Products

Wood Products (i.e., sawlogs, pulpwood or cordwood) are the property of the landowner unless otherwise specified. They will not be used for any purpose unless permission is first obtained from the landowner. When the landowner requests salvage of these materials or approves wood products to be stockpiled and left on site, they will be stockpiled just off the edge of the construction work area, but not within 50 feet of streams, floodplains, or wetlands. Equipment stacking the wood products will not leave the construction work area. Usable timber that measures at least 10 inches in diameter at the butt will be cut into pole lengths or as otherwise negotiated with the landowner. Off-site disposal in other than commercially operated disposal locations is subject to compliance with all applicable survey, landowner approval and mitigation requirements.

### 2. Brush

All cleared brush will be disposed of by one of the following methods:

- Brush may be piled just off the edge of the construction work area but not within 50 feet of streams, floodplains or wetlands. Equipment stacking the brush will not leave the construction work area. Brush piles will be constructed a maximum of 12 feet wide and compacted to approximately 4 feet high, with periodic breaks at a minimum of every 200 feet to permit wildlife travel. The landowner should be consulted to determine acceptable brush pile locations along the construction work area. Landowner approval is required for this method.
- Brush may be burned where permitted by law. The necessary burning permits will be obtained. Fires will be of reasonable size and located and patrolled so that they will not spread off the construction work area.

- The brush may be chipped and given away, buried, or thinly spread (less than 2 inches thick) over the construction work area or blown off the construction work area (per landowner agreement and approvals) except in **agricultural lands** or within 50 feet of streams, floodplains, or wetlands. Chipping will be limited to those areas where agreed to with the landowner. During **restoration**, soil will be augmented by the addition of 12 to 15 pounds of nitrogen per ton of chips to aid revegetation\*.
- Brush may be hauled off-site. Off-site disposal in other than commercially operated disposal locations is subject to compliance with all applicable survey, landowner approval and mitigation requirements.

\*One ton of chips spread 1 inch thick cover approximately  $\frac{1}{4}$  acre.

### 3. Fence Crossings

Where it is necessary to remove fences, adequate temporary fences or gates as illustrated in Figure 4 will be installed **immediately** or in accordance with landowner agreement. Such temporary fences or gates will be kept closed, except when necessary for construction purposes per landowner agreement. Once construction is completed, permanent fence repairs will be completed. All fences that have been cut or removed will be permanently repaired during restoration to match the original type of the fence as much as possible. Where there is any doubt as to the usability of old fence material, new material will be used in making repairs. Fence repairs will be subject to the approval of the landowner.

#### D. Grading

Grading is necessary to provide a smooth and even surface for safe and efficient operation of construction equipment. Grading will be the minimum amount necessary and includes prompt installation of erosion control devices such as interceptor diversions, **sediment filter devices**, and equipment crossings at streams to minimize soil loss and subsequent sedimentation.

##### 1. Tree Stump and Rock Removal and Disposal

Tree stumps and large rocks will be cut, graded or removed as necessary to permit construction and to provide adequate clearance for mechanical equipment and other vehicles. Tree stumps that are adjacent to roads will be cut close to the ground or removed.

Stumps and large rocks will be disposed of in the following manner with landowner approval. Off-site disposal in other than commercially operated disposal locations is subject to compliance with all applicable survey, landowner approval and mitigation requirements.

- buried within the construction work area except in agricultural, residential, or wetland areas;
- windrowed just off the edge of the construction work area with landowners' permission. Windrows will be a maximum of 12 feet wide with periodic breaks a minimum of 200 feet apart;
- hauled from the site and disposed of in an approved landfill or other suitable area.

## 2. Topsoil Conservation

Unless the landowner or land management agency specifically approves otherwise, prevent the mixing of topsoil with subsoil by stripping topsoil from either the full work area or from the trench and subsoil storage area (ditch plus soil side method) in:

- actively cultivated or rotated croplands and pastures;
- residential areas;
- hayfields; and
- other areas at the landowner's or land managing agency's request.

In deep soils (more than 12 inches of topsoil), segregate at least 12 inches of topsoil. In soils with less than 12 inches of topsoil make every effort to segregate the entire topsoil layer. Segregated topsoil may not be used for padding the pipe. Figure 5 illustrates topsoil conservation techniques.

The topsoil will be stockpiled separately from all subsoil and will be replaced last during backfilling and **final grading**. Where topsoil is stripped from the entire construction ROW, an additional 25-foot wide temporary work area may be used for topsoil storage with landowners' permission and appropriate environmental approvals. The **Inspector** will determine if additional erosion control devices are needed in topsoil storage areas.

In residential areas, topsoil replacement (i.e., importation of topsoil) is an acceptable alternative to topsoil segregation.

## 3. Erosion Control Devices

Temporary erosion controls will be installed immediately after or during the initial disturbance of soil. The most effective and versatile erosion control devices are interceptor diversions (temporary slope breakers) and sediment filter devices as illustrated and described in Figures 6A, 6B, 7, and 8. Temporary diversions will be maintained during the construction phase until final diversions are installed. Where required grading has significantly reduced the slope, the Inspector may require fewer temporary diversions consistent with the table on Figure 6.

At a minimum, install and maintain temporary sediment barriers (silt fence, staked hay or straw bales, compacted earth, sand bags, or other appropriate materials) across the entire construction right-of-way at the base of slopes greater than 5 percent where the base of the slope is less than 50 feet from a waterbody, wetland, or road crossing until revegetation is successful. Leave adequate room between the base of the slope and the sediment barrier to accommodate ponding of water and sediment disposition.

All temporary erosion control devices, including roadside ditches, will be inspected near the end of each work day or after each storm (rain) event of 1/2 inch or greater, to ensure proper functioning. Any devices damaged beyond functioning will be repaired **promptly**.

#### **4. Temporary Road Entrances**

Temporary road entrances as illustrated in Figures 9, 10, and 11 will be installed during grading where the construction work area crosses public roads when needed to maintain safe conditions and to prevent tracking soil and mud onto public roads. These installations are designed to remove mud from vehicle tires and tracks before accessing the road. In addition, public roads will be swept, shoveled or scraped as necessary to keep the road surface safe. If the public road is gravel, the temporary entrance is not required to be graveled. Typical erosion control measures at road crossings are illustrated in Figure 12. If no access is required onto the roadway the installation of a construction entrance is not required, however, safety fencing should be installed across the ROW and signs designating "no entrance" can be erected to avoid any unintentional entrances.

#### **E. Access Roads**

Typically, Columbia requires access roads to the construction and staging areas. New access roads will be built only if existing access is inadequate. The access roads will be a maximum 25-foot wide with additional width in tight turns and at intersections with public roads. The roads will either be temporary (used for access during construction only) or permanent (used during and after construction for operation and maintenance of the facilities). All public roads are available for use as access roads without further environmental review. However, all private access roads intended for use are subject to environmental reviews. Safe and accessible conditions will be maintained at all roadway crossings and access points during construction and restoration.

Access road gradient will be as flat as local topography will practically allow. By breaking or changing grade frequently, fewer erosion problems will be encountered than on long, straight, continuous gradients. Interceptor diversions and/or other erosion and sediment control devices will be installed as needed.

At temporary road entrances, geotextile fabric will be used as illustrated in Figures 9, 10 and 11. The roadbed should be cleared of small stubs because

these tend to puncture the fabric, thereby allowing fine particles to mix with the gravel. Geotextile fabric not required at existing, graveled access road entrances, if gravel is to be left after construction landowner approval is required.

Roads will cross streams and wetlands as close as possible to right angles. Road gradients approaching these crossings will be flattened to decrease runoff velocity. Runoff will be dispersed just prior to the crossing by means of an interceptor diversion with a sediment filter device at the outlet. Where conditions permit, new roads will be located at least 25 feet from any stream or wetland except at crossing locations. Culverts will be sized and placed to permit water flow under the access road.

After construction, temporary access roads (including any additional width used for construction) will be graded and left intact for the landowner's benefit, or removed and the area restored using the same specifications as applied to the construction work area.

## **F. Residential Areas**

The following mitigation measures will be implemented for all residences within 50 feet of the construction work area:

- mature trees and landscaping will not be removed from within the edge of the construction work area unless necessary for safe operation of construction equipment;
- immediately after backfilling the trench, all lawn and landscaping will be restored to final restoration, or temporary restoration pending weather and soil conditions;
- while the trench is open, the edge of the construction work area adjacent to the residence will be safety fenced for a distance of 100 feet on either side of the residence to ensure that equipment, materials and spoil remain within the construction work area;
- a minimum of 25 feet will be maintained between the residence and construction work area for a distance of 100 feet on either side of the residence. If the facility must be within 25 feet of a residence, it must be installed such that the trench does not remain open overnight.

## **G. Trenching**

### **1. Trenching Specifications**

Typically, the trench will not remain open for more than 30 days in any area unless authorized by the Inspector (additional restrictions for stream and wetland areas are provided in Section III).

- As the trench is completed, trenchline breakers as illustrated in Figure 13 will be installed promptly at every second temporary



interceptor diversion at a minimum. Topsoil will not be used to construct the breakers. The breakers reduce water velocity and erosion of the trench bottom. The breakers will be maintained promptly.

- Sediment filter devices will be installed around spoil storage areas before digging bore pits, stream crossings, and as necessary wetland crossings.
- If it is necessary to pump water from the trench or bore pits, the water will be pumped into a heavily vegetated upland area where the water will filter back into the ground, a sediment trap as illustrated in Figure 14A, a sediment filter bag as illustrated in figure 14B, or through a sediment filter device such as a series of terra tubes. Sediment logs or flocculent logs at least 10 feet from any stream or wetland in order to minimize erosion and subsequent sedimentation of streams or wetlands. Water impounded in the trench will not be released directly or by overland flow into any **waterbody** or wetland. Dewater the trench in a manor that does not cause erosion and does not result in heavily silt laden water flowing into a waterbody or wetland.

When the trench must remain open for a greater length of time, appropriate erosion controls and safety measures will be employed as directed by the Inspector.

## **2. Blasting**

All drilling and blasting will be done in a cautious manner, and suitable precautions will be taken to avoid injury or damage to persons, livestock, or other property.

If blasting is necessary within 150 feet of residential or commercial buildings, An independent contractor will be hired to perform pre- and post-blast structural inspections and, if necessary, seismographic monitoring.

In those instances where blasting has the potential to affect water quantity/quality from domestic or agricultural wells or springs in the proximity of the construction work area, Columbia will conduct pre- and post-blasting (within two months of construction work restoration) testing of water wells within an appropriate distance (typically 150 feet) of the pipeline with landowner permission. These tests may include a pump inspection, flow rate, and bacteriological cultures. If a water well is damaged as a result of Columbia's activities, Columbia will provide a temporary source of water and/or compensate the owner.

## **3. Temporary Construction Access Over the Trenchline**

Where access across the trenchline is required, temporary facilities such as trench plugs and fences, wooden mats or steel plates will be

constructed or installed to permit safe crossing of livestock, vehicles, equipment, and persons from one side of the trench to the other.

#### **4. Drainage Tile and Irrigation Facilities**

Attempt to locate existing drain tiles and irrigation systems. Columbia personnel will contact landowners and/or the local National Resource Conservation Service (NRCS) to determine the locations of future drain tiles that are likely to be installed within 3 years of the authorized construction, if planned, the pipeline will be installed at a sufficient depth to accommodate the drainage tile. For adjacent pipeline loops in agricultural areas, install the new pipeline with at least the same depth of cover as the existing pipeline(s) and within US Department of Transportation (DOT) specifications. Mark locations of drain tiles damaged during construction.

Engage qualified drain tile specialists, as needed to conduct or monitor repairs to drain tile systems affected by construction. Use drain tile specialists from the project area, if available. Drainage tile removed, cut, broke, or otherwise damaged during construction will be repaired or replaced as illustrated in Figure 15. Temporary measures approved by the Inspector will be taken to provide suitable drainage until permanent repairs are made. Repair damaged drain tiles to their original or better condition. Do not use filter-covered drain tiles unless the local soil conservation authorities and landowner agrees.

Water flow will be maintained in crop irrigation systems unless shutoff is coordinated with affected parties.

#### **H. Backfilling Specifications**

Backfilling will follow pipe lowering as closely as practical. Topsoil will not be used to pad the pipe. Soil that has been excavated during construction and not used for backfill will be evenly spread over the cleared construction work area or removed from the site and properly disposed. All waste materials such as barrels, cans, drums, stumps, coating and wrap, rubbish, waste, or other refuse will not be placed in the trench.

Trenchline barriers as illustrated in Figure 13 will be placed in the trench prior to backfilling to prevent water movement and subsequent erosion. An engineer or similarly qualified professional shall determine the need for and spacing of trenchline barriers. Otherwise, trenchline barriers shall be installed at the spacing illustrated in Figure 13 and up-slope of any permanent interceptor diversions.

Excess rock, including blast rock, may be used to backfill the trench to the top of the existing bedrock profile. Care should be taken to not damage the pipeline.

#### **I. Final Grading, Restoration and Stabilization**

After construction activities, all disturbed areas will be stabilized with either (1) final grading and restoration; or (2) **temporary stabilization** measures in order to prevent erosion and sedimentation until final grading and restoration can be completed.

## 1. Final Grading

Final grading will be completed within 20 calendar days of backfilling (10 days in residential areas), weather and soil conditions permitting. Should unsuitable soil conditions persist, or be expected to persist, for more than 20 calendar days (10 days in residential areas), the Inspector will record the conditions and require the installation of temporary stabilization measures, and final grading and restoration will be delayed until conditions allow. In no case shall final grading be delayed beyond the end of the next recommended seeding season.

If final grade can be established, but conditions are not ideal for permanent seeding, the Inspector will specify application of temporary stabilization measures (including temporary seeding), and may also consider concurrent application of final seed mix and mulch as provided in Table 2a or per the local conservation authority.

Grade the construction right-of-way to restore pre-construction contours.

During final grading, soil over the trench may be mounded to allow for future settling. Where fill in the trench or major depressions have settled below ground level, additional fill will be added as needed, and the area brought to final grade. The Inspector may approve a temporary travel lane in the construction work area where needed to facilitate the remainder of construction and/or restoration. This travel lane must be restored when access through the area is no longer required.

Conserved topsoil will be returned during final grading.

Excess rock will be removed from at least the top 12 inches of soil to the extent practicable in all actively cultivated or rotated agricultural land, hayfields, pastures, residential areas, and other areas at the landowner's request. The size, density and distribution of rock on the construction work area should be similar to adjacent areas not disturbed by construction. Diligent efforts will be made to remove rocks greater than 4 inches if, off-construction work areas do not contain rocks greater than 4 inches. The landowner may approve other rock size provisions in writing.

Final erosion control devices including interceptor diversion/slope breakers will be installed during final grading. Sediment filter devices needed to protect off-construction work area resources will be installed or rebuilt promptly after final grading. Final interceptor diversions will not be installed in agricultural or pasture land without landowner's consent.

## 2. Soil Compaction Testing

Test topsoil and subsoil for compaction at regular intervals in agricultural and residential areas disturbed by construction activities. Conduct tests on the same soil type under similar moisture conditions in undisturbed areas to identify approximate preconstruction conditions. Use U.S. Army Corps of Engineers-style cone penetrometers or other appropriate devices to conduct tests.

Plow severely compacted agricultural areas with a paraplow or other deep tillage implement. In areas where topsoil has been segregated, plow the subsoil before replacing the segregated topsoil. Alternatively, make arrangements with the landowner to plant and plow under a "green manure" crop, such as alfalfa, to decrease soil bulk density and improve soil structure. If subsequent construction and cleanup activities result in further compaction, conduct additional tilling.

Perform appropriate soil compaction mitigation in severely compacted residential areas.

## 3. Restoration

Restoration as defined in Definition of Terms – Section VIII, will begin within 6 days of final grading, weather and soil conditions permitting. Fertilizer and lime will be disked into the soil (except rocky soils) to a depth of 3 to 4 inches to prepare a seedbed. In rocky soils, fertilizer and lime may be incorporated into the soil with tracked equipment. Seeding and mulching the construction work area will promptly follow seedbed preparation. Ensure that mulch is adequately anchored to minimize loss due to wind and water. Mulch tacifiers used in accordance with the manufacturers recommendations may be used as an alternative. Do not use liquid mulch binders within 100 feet of wetlands or waterbodies.

The typical application rates for lime, fertilizer, seed and mulch are listed in Table 2a. They will be used unless the ROW agreement, permit or local NRCS provides project-specific recommendations. If Tall Fescue is used, plant endophyte free certified seed.

If hydroseeding is utilized, lime and fertilizer applications should be equivalent to table 2a unless ROW agreement, permit or the local NRCS provides project specific recommendations. Hay or straw mulch shall be applied in accordance with table 2a over hydroseeding. Hydromulch can be used in conjunction with (for texture purposes) but not substituted for hay or straw mulch. **Scarify** the seedbed to facilitate lodging and germination of seed.

Uniformly apply and cover seed in accordance with the written recommendations of the local soil conservation authorities or land management agencies.

Base seeding rates on Pure Live Seed. Use seed within 12 months of seed testing. Treat legume seed with an inoculate specific to the species using the manufacturer's recommended rate of inoculant appropriate for the seeding method. If the above recommendations are not available for conventional seeding, use 4 times the manufacturer's recommended rate of inoculant. For hydroseeding, use 10 times the recommended rate of inoculant.

In the absence of recommendations from the local conservation authority, a seed drill equipped with a cultipacker is preferred for application, but broadcast or hydroseeding can be used at double the recommended seeding rates. Where seed is broadcast, firm the seedbed with a cultipacker, roller or other suitable means after seeding. In rocky soils or where site conditions may limit the effectiveness of this equipment, other alternatives may be approved by the environmental inspector.

Restoration will not be performed in agricultural lands from the beginning of the spring thaw through May 15 unless requested by the landowner. Restoration will be coordinated with the landowner's planting schedule. Grazing deferment plans will be developed with willing landowners, grazing permittees, and land management agencies as appropriate to minimize grazing disturbance of revegetation efforts.

Permanent seeding, liming, and fertilizing may be performed by the landowner. The Inspector will ensure that the restoration is satisfactory and consistent with the regulatory requirements.

Restore all turf, ornamental shrubs, and specialized landscaping in accordance with the landowner's request, or compensate the landowner. Restoration work must be performed by personnel familiar with local horticultural and turf establishment practices.

Jute netting as illustrated in Figure 16 or equivalent approved by the Inspector may be used on **steep slopes** to help stabilize the construction work area.

Restoration shall be considered successful if the right-of-way surface condition is similar to adjacent undisturbed lands, construction debris is removed (unless requested otherwise by the landowner or land managing agency), revegetation is successful, and proper drainage has been restored.

Revegetation in non-agricultural areas shall be considered successful if upon visual survey the density and cover of non-nuisance vegetation are similar in density and cover to adjacent undisturbed lands. In agricultural areas, revegetation shall be considered successful if crop yields are similar to adjacent undisturbed portions of the same field.

#### **4. Temporary Stabilization**

When the Inspector determines that temporary stabilization measures are required, they will be completed as soon as possible. The seeding and mulching rates are provided in Table 2b. Consideration will be given to the following when determining if temporary stabilization measures are to be implemented:

- if final grading and installation of permanent interceptor diversions or slope breakers will not be completed in an area within 20 days after the trench in that area is backfilled (10 days in residential areas);
- anticipated weather conditions; and
- resources on and off the construction work area to be protected.
- Construction or restoration activity is interrupted for extended periods.

If temporary stabilization measures are utilized, final grading and/or restoration must commence once weather and soil conditions permit.

Apply mulch in accordance with the specifications outlined in this section however, during temporary restoration; increase mulch application on all slopes (8 percent or more) within 100 feet of waterbodies and wetlands to a rate of 6,000 lbs/acre (3 tons).

## **5. Restoring Man-Made Structures**

All existing man-made installations that are disturbed or damaged during construction along new ROW will be repaired or replaced and left in equivalent or better condition than they were found prior to construction, unless alternative arrangements with landowners dictate otherwise.

Man-made installations on existing ROW that are disturbed or damaged during construction will be addressed consistent with Columbia's encroachment policy.

## **6. Off-Road Vehicle (ORV) Control**

Columbia will discuss with each landowner and park manager along new ROW (not adjacent to existing ROW) in forest lands the need for ORV control. If requested, one or more of the following ORV control measures will be installed:

- Plant conifers (pine trees) across the construction work area. The spacing of trees and length of construction work area planted should provide for adequate facility maintenance, but should be sufficient to limit access and to screen the ROW from view. Trees will not be planted directly over the pipeline.

- Install a slash and timber barrier, a pipe barrier, or a line of boulders across the construction work area to restrict vehicle access.
- Install a locking gate with fencing extending a reasonable distance to prevent bypass.
- Install “No Trespass” signs.

**J. Noise Impact Mitigation and Dust Control**

Construction equipment will be properly muffled and maintained to avoid producing excessive noise near **noise sensitive areas**.

Efforts will be made to control dust at sensitive areas such as residential areas and road crossings. Water trucks will be used at a minimum to dampen the work area if dust becomes a problem.

**K. Hydrostatic Testing**

Typically, Columbia verifies a facility’s integrity by hydrostatic testing. Water will be drawn from local sources (streams, ponds, public water supplies) in a manner that will minimize impacts to the environment and other existing users, while maintaining adequate stream flow. Water from state designed *high quality streams* or *exceptional value waters*, waterbodies which provide habitat for federally listed threatened or endangered species, or streams utilized as public water supplies will not be used unless other water sources are not readily available and the appropriate federal, state or local agency permits its use.

Intake hoses will be screened.

Locate hydrostatic test manifolds outside wetlands and riparian areas to the maximum extent practicable.

All required federal, state and local approvals for the withdrawal and/or discharge of hydrostatic test water will be obtained prior to such activities.

Jurisdictional agencies will be notified of the intent to withdraw water from streams. Notify appropriate state agencies of intent to use specific sources at least 48 hours before testing activities unless they waive this requirement in writing.

Maintain adequate flow rates to protect aquatic life and provide water for downstream withdrawals by existing users.

Comply with all approval/permit conditions which may include notifying the appropriate state agency of withdraw/discharge and collection of samples in accordance with permit conditions where required.

All welds will be radiographically inspected or hydrostatically tested before pipe installation under waterbodies or wetlands.

The discharge of the hydrostatic test water will be performed in a manner that minimizes erosion. The energy of the released test water will be dissipated by discharging the water:

- into a well-vegetated upland area;
- into a tank(s)
- into a body of water (with all required permits); or
- through sediment filter devices or a sediment trap to filter out various particulate matter or allow it to infiltrate through the soil.

If necessary, regulate the water discharge rate, use energy dissipation device(s); and/or install sediment barriers to prevent erosion, streambed scour, suspension of sediments, or excessive streamflow. During the discharge, the Inspector must ensure that erosion and sedimentation are properly controlled.

Do not discharge into waters from state designated exceptional value waters, waterbodies which provide habitat for federally listed threatened or endangered species, or streams utilized as public water supplies unless the appropriate federal, state or local agency grants permission.

Methanol may be injected, after discharging the water, to dry the pipe. Excess methanol will be retrieved from the facility and used during subsequent operation of Columbia's facilities.

This guidance is for hydrostatic testing of new pipe. Permitting requirements associated with hydrostatic testing of used pipe can be extensive. Contact the Construction Permitting Specialist prior to testing any used pipe.

### **III. STREAM AND WETLAND CROSSINGS**

#### **A. Stream Crossings**

##### **1. General**

The main objective of any waterbody crossing is to construct the pipeline in a manner, which minimizes erosion and subsequent sedimentation into the waterbody. Crossings will be constructed as close as possible to right angles with the waterbody channel. Adequate downstream flow rates will be maintained at all times to protect aquatic life and prevent the interruption of existing downstream uses. Each waterbody crossing will be treated as a separate construction entity, such that trenching, pipe installation, backfilling and temporary stabilization or final restoration are completed in the minimum number of consecutive calendar days possible.

Whenever a time limit is imposed on a crossing procedure, that time limit is only applicable to trenching (except blasting), lowering in, and backfilling. Clearing, grading and equipment crossing installation and



removal activities are not included as part of the separate construction entity. Construction equipment will not be allowed in the water except as provided in this Section.

Unless expressly permitted or further restricted by the appropriate state agency in writing on a site-specific basis, crossings must be constructed during the following time windows:

- Coldwater Fisheries - June 1 through September 30
- Coolwater and Warmwater Fisheries - June 1 through November 30

Columbia will notify in writing authorities responsible for potable water supplies at least one week, or as required by state or local regulation, prior to any waterbody crossing.

When water levels are temporarily high, the Inspector will direct that starting any waterbody crossing be postponed until water levels subside.

Any extra work areas will be located at least 50 feet away from the water's edge, except where the adjacent upland consists of actively cultivated or rotated cropland or other disturbed land. Where topographic conditions do not permit a fifty-foot setback, contact the Natural Resources Permitting group for approval. All extra work areas must be located at least 10 feet from the water's edge and limited to the size needed to construct the crossing. Pipe assembly for the waterbody crossing is usually performed in the extra work areas prior to or concurrently with trenching.

Standards relating to spill prevention at waterbodies are contained in Section IV, "Spill Prevention".

If the facility parallels a waterbody, attempt to maintain at least 15 feet of undisturbed vegetation between the waterbody and the right-of-way except at the crossing location. Where waterbodies are adjacent to the construction right-of-way, install sediment barriers along the edge of the construction right-of-way as necessary to contain spoil and sediment within the right-of-way.

Waterbody buffers (extra work area setbacks, refueling restrictions, etc.) must be clearly marked in the field with signs and/or highly visible flagging until construction related ground disturbing activities are completed.

## 2. **Crossing Techniques**

Columbia typically utilizes either the dry-ditch (flume pipe) wet-ditch; or Dam and Pump techniques to install pipelines across waterbodies. Figures 18, 19 and 20 illustrate these methods. **Upland construction** techniques may be used for **intermittent waterbody** crossings without perceptible flow at the time of the crossing, provided that a culvert is

**promptly** installed to carry stormwater flow across the trench area and the erosion and sediment control devices illustrated in Figure 17 are installed.

**a) Minor Waterbodies**

For crossings of coldwater fisheries and coolwater and warmwater fisheries considered significant by the state, install the pipeline using the dry-ditch method or Dam and Pump method, unless approved otherwise in writing by the appropriate state agency.

For other **minor waterbody** crossings, complete instream construction in the waterbody using the wet-ditch method within 24 hours (except for blasting and pneumatic chipping; see Section III.6.). Limit use of equipment operating in the waterbody to that needed to construct the crossing.

**b) Intermediate Waterbodies**

The wet-ditch method can be used for **intermediate waterbody** crossings. Only the equipment necessary for excavating the trench, lowering-in the pipe, and backfilling the trench is allowed in the waterbody. Columbia will attempt to complete trenching and backfill work in the waterbody within 48 hours, unless site-specific conditions make completion within 48 hours infeasible.

For crossings of coldwater fisheries and coolwater and warmwater fisheries considered significant by the state 10 to 30 feet in width, install the pipeline using the dry-ditch method or Dam and Pump method, unless approved otherwise in writing by the appropriate state agency.

**c) Major Waterbodies**

Due to their sensitive nature, **major waterbody** crossings will have site-specific construction plans approved by the Natural Resource Permitting group. Directional drilling may be considered as an alternative for these crossings.

**3. Clearing**

Tree and brush clearing will be performed as previously described in Section II, "Upland Construction". All cleared materials will be disposed of at least 50 feet from the water's edge.

**4. Grading**

Grading equipment will not enter the water to grade the banks. Waterbody banks will be graded only where, and as much as, necessary to permit safe and efficient operation of construction equipment. During

grading operations, sediment filter devices will be installed across the entire construction right-of-way promptly and as close to the water as practical. Removable sediment filter devices must be installed across the travel lane. These removable sediment filter devices, if removed during the day, must be re-installed by the end of the work day or when heavy precipitation is imminent. All disturbed areas within 50 feet of the water's edge will be promptly mulched. The mulch will be maintained until the waterbody crossing restoration is complete. Spoil from grading will be piled at least 10 feet from the stream banks and immediately protected with sediment filter devices so that it will not erode into the waterbody. On waterbody crossings with approaches sloped 5 percent or greater, interceptor diversions will be installed 50 feet from the water's edge to divert surface runoff into adjacent vegetation. If vegetation is sparse or nonexistent, a sediment filter device will be installed at the discharge of the diversion. Install a sediment filter device across the entire construction right-of-way at the base of slopes 5 percent or greater where the base of the slope is less than 50 feet from a stream. Leave adequate room between the sediment filter device and base of the slope for sediment deposition.

Construction equipment bridges consisting of culvert(s) with clean rock fill of non-erodable material or equipment pads as illustrated in Figures 21 and 22 will be installed during grading operations at all waterbodies. For proper culvert installation, the Inspector may permit grading/excavating equipment to enter the water. Equipment bridges are not required at minor waterbodies that do not have a state-designed fishery classification (for example, agricultural or intermittent drainage ditches). However, if an equipment bridge is used, it must be constructed in accordance with this ECS. Construct equipment bridges to maintain unrestricted flow and to prevent soil from entering the stream.

## **5. Trenching**

Notifications to applicable jurisdictional agencies will be made at least 2 days prior to any trenching in waterbodies, or as specified in permits

Prior to trenching within the waterbody, water impounded in the upland trench will be pumped into a into a sediment trap( Figure 14A) and/or properly installed filter bag (Figure 14B) and/or a series of terra tubes, sediment logs or flocculent logs, or a heavily vegetated upland area where the water can filter back into the ground. Prevent the flow of spoil or heavily silt-laden water into any waterbody.

Sediment filter devices for trench spoil will be installed prior to commencing trenching activities. Sediment filter devices can be temporarily removed from the trench line only to allow trenching activities to proceed.

All spoil from minor and intermediate waterbody crossings, and upland spoil from major waterbody crossings, must be placed in the construction

ROW at least 10 feet from the water's edge or in additional extra work areas.

For all new construction activities, the minimum depth of cover for all waterbody crossings is 48 inches in normal soils and 24 inches in consolidated rock.

Trench plugs will be used at all non-flumed waterbody crossings to prevent diversion of water into upland portions of the pipeline trench and to keep any accumulated trench water out of the waterbody. Trench plugs must be of sufficient size to withstand upslope water pressure.

For dry ditch method crossings, use sand bag or sand bag and plastic sheeting diversion structure or equivalent to develop an effective seal and to divert stream flow through the flume pipe (some modifications to the stream bottom may be required in to achieve an effective seal). In addition, do not remove flume pipe during trenching, pipelaying, or backfilling activities, or initial streambed restoration efforts.

## **6. Blasting**

During the pre-planning of waterbody crossings, an evaluation will be made concerning the need for blasting. If the evaluation is inconclusive, the waterbody bed will be tested for consolidated rock prior to trenching. Blasting will not be done within waterbody channels without prior approval from applicable government authorities having jurisdiction and at least 2-day notice to the authority, or as specified in permits

If the waterbody bottom is consolidated rock, it can be drilled and shot at any time prior to commencing the crossing. However, removal of shot rock, and any additional drilling, shooting and material removal, must be completed within the minimum number of consecutive calendar days practical. The time frame for completing the crossing will immediately commence once a trench of appropriate dimensions is established.

## **7. Backfilling**

Waterbody bottoms will be returned as near as practical to their original contours. Spoil from the trench will be used as backfill. Clean gravel or native cobbles will be used for the final one-foot of fill in the backfilled trench in all coldwater fisheries.

The sediment filter devices removed at the stream will be promptly reinstalled after backfilling.

## **8. Restoration**

The preferred restoration method is to achieve final grade and restore the waterbody, its banks, and 50-foot buffers within 24 hours of backfilling. In the absence of site-specific seeding recommendations, the specifications

listed in Table 2a will be used. If conditions do not permit the preferred method, the construction work area not in use for access will be promptly rough graded and stabilized in accordance with Table 2b.

Stabilize waterbody banks and install permanent sediment barriers/sediment filter devices within 24 hours of completing the crossing. For dry-ditch crossings, complete streambed and bank stabilization before returning flow to the waterbody channel.

Liquid mulch binders will not be used within 100 feet of waterbodies.

For each waterbody crossed, install a permanent interceptor diversion/slope breaker and a trench breaker at the base of slopes near the waterbody. Locate the trench breaker immediately upslope of the interceptor diversion/slope breaker.

All equipment bridges will be removed once access in the area is no longer required.

Return all waterbody banks to preconstruction contours or to a stable angle of repose as approved by the Environmental Inspector. If the waterbody banks are such that an unstable final soil grade would result and vegetative stabilization is inadequate, the Inspector will require mechanical stabilization of the waterbody banks. Mechanical stabilization includes riprap, gabions, jute netting, etc.

Unless otherwise specified by state permit, limit the use of riprap to areas where flow conditions preclude effective vegetative stabilization techniques, such as seeded erosion control fabric.

Revegetate disturbed riparian areas with conservation grasses and legumes or native plant species, preferably woody species.

Application of riprap must comply with the US Army Corps of Engineers, or its delegated agency, permit terms and conditions. In general, riprap will be of field or quarry run stone, which is hard and durable. The riprap will be large enough to prevent normal waterbody current from moving it, typically 6-inch rock for slow moving waterbodies and 12 inch or larger rock for others. The riprap will be placed at least 18 inches thick and generally thicker at the base. The riprap slope will be no steeper than 1:1 and should conform with the remainder of the waterbody bank slopes where they are flatter than 1:1.

Install erosion control fabric, figure 16, such as jute thatching or bonded fiber blankets at a minimum, on waterbody banks at the time of final bank re-contouring. Anchor the erosion control fabric with staples or other appropriate devices.

Sediment filter devices will be removed once permanent revegetation is successful.

## **B. Wetland Crossings**

### **1. General**

The main objective of any wetland crossing is to construct the pipeline and restore the original contour of the wetland. Wetlands will be clearly marked in the field by a knowledgeable person prior to the start of construction with signs and/or highly visible flagging until construction is complete. The Inspector will maintain these field markings during construction. A maximum 75-foot wide construction work area may be used through wetlands.

Mulch will not be used as a temporary erosion control measure in wetlands.

Aboveground facilities will not be located in any wetland, except where the location of such facilities outside of wetlands would prohibit compliance with US DOT regulations.

When water levels are temporarily high, the Inspector will direct that starting construction in the wetland will be postponed until after the water levels subside.

Standards relating to spill prevention at wetlands are contained in Section IV, "Spill Prevention".

### **2. Crossing Techniques**

For wetland crossings without standing water or saturated soils, upland construction techniques can be used provided the top 12 inches of soil taken from the trench is stockpiled separately from the remaining excavated material. The construction right-of-way may be used for access when the wetland soil is firm enough to avoid rutting or the construction right-of-way has been appropriately stabilized to avoid rutting (e.g., with timber riprap, prefabricated equipment mats, or terra mats). In wetlands that cannot be appropriately stabilized, all construction equipment other than that needed to install the wetland crossing shall use access roads located in upland areas. Where access roads in upland areas do not provide reasonable access, limit all other construction equipment to one pass through the wetland using the construction right-of-way.

Wetland crossings in non-saturated soil wetlands will be constructed in a manner that will minimize the amount of time construction activities are occurring in the wetland, such as the length of time the topsoil is segregated and the trench is open.

Wetland crossings with standing water or saturated soils will be constructed as separate construction entities, such that trenching, pipe

installation, backfilling, and restoration are completed in the minimum number of consecutive calendar days necessary. Clearing, grading and equipment crossing installations are not included as part of the separate construction entity. The “push-pull” or “float” technique of pipe installation will be utilized whenever water and other site conditions permit. Assemble the pipeline in an upland area unless the wetland is dry enough to adequately support skids and pipe.

If standing water or saturated soils are present or if construction equipment causes ruts or mixing of the topsoil and subsoil, use **low-ground-weight** construction equipment, or operate normal equipment on timber riprap (only 2 layers), prefabricated equipment mats or terra mats. Tree stumps, rock, gravel, soil imported from outside the wetland or brush will not be used to stabilize the construction work area or as equipment pads in wetlands. Remove all equipment mats, and timber riprap during restoration of the wetland.

Staging areas will be located at least 50 feet from the wetland edge except where the adjacent upland consists of actively cultivated or rotated cropland or other disturbed land and will be limited to the minimum necessary to construct the crossing. If topographic conditions do not permit a 50-foot setback, these areas must be located at least 10 feet from the wetland's edge with prior approval from the Natural Resources Permitting group.

The only access roads, other than the construction work area, that can be used in wetlands without FERC approval are those existing roads that can be used with no modification and no impact on the wetland.

Limit construction equipment operating in wetland areas to that needed to clear the construction work area, dig the trench, fabricate and install the pipeline, backfill the trench, and restore the ROW. All other construction equipment shall use access roads located in upland areas to the maximum extent practicable. Where access roads in upland areas do not provide reasonable access, limit all other construction equipment to one pass through the wetland using the construction work area.

A typical wetland crossing is illustrated in Figure 23.

### **3. Clearing**

Tree and brush clearing will be performed as previously described in Section II, “Upland Construction”. Cut vegetation off just above ground level, leaving existing root systems in place, and remove (vegetation) from the wetland for disposal.

### **4. Grading**

Grading in wetlands will consist of the minimum necessary for safe and efficient equipment operation. Limit pulling of tree stumps and grading

activities to directly over the trenchline. Do not grade or remove stumps or root systems from the rest of the construction work area in wetlands unless the Chief Inspector and **Environmental Inspector** determine that safety-related construction constraints require removal of tree stumps from under the working side of the construction work area. Areas where stumps are removed will be noted by the Inspector so, if necessary, those areas can be replanted with woody vegetation as described in wetland restoration.

Where wetlands are adjacent to the construction right-of-way and the right-of-way slopes toward the wetland, install sediment barriers along the edge of the construction work area as necessary to prevent sediment flow into the wetland. Remove these sediment barriers after successful restoration has occurred.

Sediment filter devices will be installed promptly across the construction work area during grading at any wetland edge and maintained until construction work area revegetation is complete. Temporary interceptor diversions will be installed adjacent to wetlands. Locations for these devices are illustrated in Figure 23.

#### **5. Trenching**

Sediment filter devices can be temporarily removed from the trenchline to allow trenching activities to proceed. Spoil piles will be protected with sediment filter devices, if determined necessary by the Inspector, to prevent the flow of spoil off the construction work area.

#### **6. Blasting**

During the pre-planning of crossing wetlands with standing water or saturated soils, an evaluation will be made concerning the need for blasting. If the evaluation is inconclusive, the wetland will be tested for consolidated rock prior to trenching. If the wetland has consolidated rock, it must be drilled and shot as part of the single construction entity.

#### **7. Backfilling**

If trench dewatering is required, the water will be filtered and discharged through a sediment trap (Figure 14A) and/or filter bag (Figure 14B) and/or a series of terra tubes, sediment logs or flocculent logs or into a heavily vegetated area outside the wetland (where the water will filter back into the ground), so that no heavily silt-laden water enters directly into a wetland or waterbody. Remove any dewatering structure as soon as possible after the completion of dewatering activities. Spoil from the trench will be used as backfill. The surface will be recontoured as closely as practical to the original condition so that drainage patterns will not be changed. The conserved topsoil layer will be returned to the surface after backfilling.



Sediment filter devices will be promptly installed after backfilling.

Where the pipeline trench may drain a wetland, construct trenchline barriers and/or seal the trench bottom as necessary to maintain the original wetland hydrology. For each wetland crossed, install a permanent interceptor diversion and trenchline barriers at the base of slopes near the boundary between the wetland and adjacent upland areas. Locate the trenchline barriers immediately upslope of the interceptor diversion.

Concrete coating activities will not take place within 100 feet of any wetland.

## **8. Restoration**

For each wetland crossed, install a trench breaker at the base of slopes near the boundary between the wetland and adjacent upland areas. Install a permanent slope breaker/interceptor diversion across the construction right-of-way at the base of a slope greater than 5 percent where the base of the slope is less than 50 feet from the wetland, or as needed to prevent sediment transport into the wetland. In addition, install sediment barriers/sediment filter devices as shown in Figure 23. In some areas, with the approval of the Environmental Inspector, an earthen berm may be suitable as a sediment barrier adjacent to the wetland.

Consult with the appropriate land management or state agency to develop a project-specific wetland restoration plan. The restoration plan should include measures for re-establishing herbaceous and/or woody species, controlling the invasion and spread of undesirable exotic species (e.g., purple loosestrife and phragmites), and monitoring the success of the revegetation and weed control efforts.

Upon completion of construction in wetland areas with standing water or saturated soils, all access improvements will be promptly removed. In the absence of specific recommendations from conservation authorities, the seed mix and rate specified in Table 2c will be used. Fertilizer, lime or mulch will not be used, unless required in writing by a jurisdictional agency.

Asphaltic emulsions will not be used to stabilize mulch within 100 feet of wetlands. Liquid mulch binders will not be used within 100 feet of wetlands.

## **IV. SPILL PREVENTION, CONTAINMENT AND CONTROL**

### **A. General**

Spills of any amount of petroleum products or polluting materials are to be prevented. The following will be followed to help avoid spills and minimize the impact of spills, which accidentally occur:

- Bulk quantities up to 5,000 gallons of diesel fuel and 5,000 gallons of gasoline will be stored in one location (the fuel depot) for the Project. Adequate spill containment measures, such as containment dikes, combined with impervious lining will be installed before fuel storage tanks are filled, and will be maintained throughout the Project. Bulk quantities of hazardous liquids (e.g., solvents and lubricants) will be stored at the fuel depot locations.
- Generally, fuel will be stored at the equipment staging areas and as much equipment as practical will be refueled there. Any equipment that must be refueled in the field will be fueled from tanks carried to the work site. Fuel carriers (greater than 110 gallons capacity) will not be permitted to cross wetlands or ford waterbodies. Equipment refueling will not be performed within 100 feet of any body of water or wetland except by hand-carried cans (5 gallon maximum capacity) when necessary. If construction equipment must be refueled within 100 feet of a waterbody, follow the procedures outlined in the project-specific SPCC Plan. Care will be taken during refueling not to overfill or spill fuel onto the housing of equipment.
- Lesser quantities of fuel (up to 500 gallons) and solvents and lubricants (e.g., motor oils, hydraulic fluid) may be stored along the construction work area as necessary to service equipment used on the Project (quantities vary depending on the size of the construction spread being used), provided that this storage does not conflict with other parts of this plan. Sorbent booms and clean-up kits will be kept at all storage locations and will be readily available at all times.
- All fuel storage areas will be located at least 100 feet from streams, ponds, or wetlands; at least 200 feet from active private water wells, and at least 400 feet from municipal water wells, unless using an operational fuel storage area established on Columbia property. All fuel storage areas will not be located within any designated municipal watershed area (except at locations designated for these purposes by an appropriate governmental authority): Equipment servicing, lubricating and refueling will also be in accordance with these requirements whenever possible (i.e., except when stationary equipment such as drilling rigs is being used). Where these conditions cannot be met, the Environmental Inspector will prepare a supplemental SPCC plan, based on field conditions, to protect these resources.
- Use of hazardous materials for vehicle maintenance will follow the same requirements mentioned above for equipment refueling. Impervious or sorbent materials will be placed under the work area before the work begins. Additional sorbent materials will also be readily available. Waste materials created during maintenance (e.g., used oil) will be collected for proper disposal. The work site and the vehicle will be checked by a Columbia inspector after the maintenance work is complete to ensure that all hazardous materials are properly contained. All waste material,

including partially used or empty containers, discarded parts, clean up rags, and used sorbent materials, as well as discarded hazardous materials containers (e.g., oil cans, grease tubes), will be collected for proper disposal.

- All motor fuel, lube oil, chemicals, and other polluting substances will be tightly sealed and clearly labeled during transportation and storage.
- Fuel trucks, pumps, mechanics' vehicles, the contractor's foremen's vehicles and Columbia Inspectors' vehicles will be equipped with appropriate sized spill kits containing absorbent materials approved for petroleum products and have sufficient tools and material to stop leaks.
- Construction equipment will not be washed in any body of water or wetland, nor will runoff resulting from washing operations be permitted to directly enter any body of water or wetland area.
- Construction equipment, vehicles, materials, hazardous materials, chemicals, fuels, lubricating oils, and petroleum products will not be parked, stored, or serviced within 100 feet of all bodies of water and wetlands.
- All equipment will be checked, by a Columbia inspector, daily for leaks prior to beginning work in bodies of water or wetlands. Steps will be taken to repair leaks or remove the equipment from service, if necessary.

If barge mounted equipment is to be employed, the contractor will develop specific spill-prevention plans to be reviewed and approved by Natural Resource Permitting group.

## **B. Spill Cleanup**

Spills occurring during construction, operation and maintenance are to be reported immediately to the Monitoring Center at 1-800-835-7191 in accordance with Columbia policies, plans and procedures (Plan Number 120.02.01). Columbia's Environmental Health and Safety department will be responsible for contacting the appropriate agencies, except as provided for below.

If the call to the Monitoring Center is not returned within 30 minutes and the spill has impacted water, the person discovering the spill or release will contact the National Response Center at 1-800-424-8802 and report the release. That person will continue calling the Monitoring Center until a representative is reached.

If a spill should occur, Columbia will ensure immediate action is taken to minimize the impact of the spill, and see that appropriate cleanup action is immediately undertaken.

In the event of a spill into or in the vicinity of bodies of water or wetlands, the following will occur immediately:

- the source will be immediately stopped;
- the spill will be contained by placing sorbing booms or constructing dikes;
- the spill will be collected with sorbing materials, skimmed off water surfaces with booms, and/or the contaminated soil will be excavated;
- the waste materials will be properly stored and disposed in accordance with Columbia policy.

The affected areas will be restored as closely as possible to their previous condition.

If the spill is such that Columbia personnel or the on-site contractor cannot immediately and effectively respond, Columbia's environmental contractor, who specializes in spill cleanup, will be employed.

## **V. MAINTENANCE**

### **A. General**

Maintenance of Columbia's ROWs is an ongoing process, which is governed by Columbia policy, certificate and permit conditions and landowner agreements. Full width vegetation maintenance clearing shall not be done more frequently than every 3 years. However, to facilitate periodic corrosion and leak surveys, a corridor not exceeding 10 feet in width centered on the pipeline may be maintained annually in a herbaceous state. In no case shall full width vegetation maintenance clearing occur between April 15 and August 1 of any year.

Maintenance activities will be performed with emphasis on preservation and enhancement of the environment. All applicable certificate and permit conditions will be incorporated into the future maintenance plan of the facility.

Specific procedures when required by regulations will be developed in coordination with the appropriate agency to prevent the introduction or spread of noxious weeds and soil pests resulting from construction and restoration activities.

### **B. Upland Areas**

Plant growth on the ROW will be inspected regularly and maintained for the life of the facility. Follow-up inspections will occur after the first and second growing season.

Revegetation in non-agricultural areas shall be considered successful if upon visual survey the density and cover of non-nuisance vegetation are similar in density and cover to adjacent undisturbed lands. In agricultural areas,

revegetation shall be considered successful if crop yields are similar to adjacent undisturbed portions of the same field.

Continue revegetation efforts until revegetation is successful.

Monitor and correct problems with drainage and irrigation systems resulting from pipeline construction in active agricultural areas until restoration is successful.

ROW are generally maintained by mowing or other mechanical means, and through the use of herbicides. Use of herbicides will follow Columbia policy. Only those herbicides approved by the EPA will be used. Herbicide use will be in accordance with existing regulations and label instructions.

If revegetation is not successful, the area will be restored as soon as practical.

Problems with drainage and irrigation systems resulting from construction activities will be reported to the local Operations Team Leader. Corrective measures will be performed as needed.

Erosion problems on the facility ROW and access roads will be reported to the local Operations Team Leader or the Natural Resource Permitting group. Corrective measures will be performed as needed. Erosion control devices that are no longer required must be removed. Removal of the erosion control devices will be at the discretion of the local Operations Team Leader and the Engineering & Construction department. Similarly, additional erosion control devices will be installed as required.

Maintain all temporary sediment barriers in place until permanent revegetation measures are successful or the upland areas adjacent to wetlands, waterbodies, or roads are stabilized. Remove temporary sediment barriers from an area once that area is successfully restored.

Efforts to control unauthorized off-road vehicle use, in cooperation with the landowner, shall continue throughout the life of the project. Maintain signs, gates, and vehicle trails as necessary.

### **C. Waterbodies, Wetlands, And Environmentally Sensitive Areas**

Columbia will work cooperatively with appropriate government agencies in an effort to minimize the impacts of ROW maintenance in waterbodies, wetlands, and other environmentally sensitive areas.

Limit vegetation maintenance adjacent to waterbodies to allow a riparian strip at least 25 feet wide, as measured from the waterbody's mean high water mark, to grow. Figure 24 illustrates ROW maintenance standards near waterbodies.

Do not use herbicides or pesticides in or within 100 feet of a waterbody or wetland except as specified by the appropriate land management or state agency.

In wetlands, a corridor up to 10 feet wide centered on the pipeline will be maintained in a herbaceous state. In addition, trees that are located within 15 feet of the pipeline and greater than 15 feet tall may be selectively cut. All felled trees will be removed from the wetland.

Attempts will be made to prevent the invasion or spread of undesirable exotic vegetation (i.e., purple loosestrife and phragmites) within wetland areas disturbed during construction. Typically, these efforts include Columbia's wetland construction techniques and the use of approved herbicides.

Monitor the success of wetland revegetation annually for the first 3 years after construction or until wetland revegetation is successful. Revegetation should be considered successful if the cover of native herbaceous and/or woody species is at least 80 percent of the total area, and the diversity of native species is at least 50 percent of the diversity originally found in the wetland. If revegetation is not successful at the end of 3 years, develop and implement (in consultation with a professional wetland ecologist) a remedial revegetation plan to actively revegetate the wetland with native wetland herbaceous and woody plant species. Continue revegetation efforts until wetland revegetation is successful.

For certain locations through Columbia's system listed threatened, endangered, or special concern species and their habitats have been identified. In addition, eligible cultural resources, wetlands, and other environmentally sensitive areas may also have been identified. In these instances, permits normally include maintenance provisions that must be adhered to for the life of the facility.

## **VI. ENVIRONMENTAL CONSTRUCTION MANAGEMENT AND INSPECTION**

### **A. General**

Columbia is responsible for compliance with the environmental conditions contained in a Projects' EM&CP, which include all permits and other approvals. One or more Environmental Inspectors will be assigned to every Project and will report to the Natural Resources Permitting group. At least one Environmental Inspector is required for each construction spread during active construction or restoration. Environmental Inspectors shall have peer status with all other activity inspectors.

### **B. Environmental Inspector**

The Environmental Inspector is responsible for assuring that the construction activity is performed in accordance with the environmental conditions of the EM&CP and landowner requirements and have the authority to stop work and order appropriate corrective action as outlined in Section VI.E. For construction activities that are found by the Natural Resource Permitting group to have minimal environmental impacts, the Environmental Inspector may also serve to monitor other construction functions.

At a minimum, the Environmental Inspector(s) shall be responsible for:

- ensuring compliance with the requirements of the EM&CP, ECS, and any permits, landowner agreements or FERC certificates obtained for the Project;
- Identifying, documenting and overseeing corrective actions, as necessary to bring an activity back into compliance.
- verifying that the limits of authorized construction work areas and locations of access roads are properly marked before clearing;
- verifying the location of drainage and irrigation systems;
- identifying erosion/sediment control and stabilization needs in all areas;
- locating dewatering structures and interceptor diversions to ensure they will not direct water into known cultural resource sites or locations of sensitive species;
- verifying that trench dewatering activities do not result in the deposition of sand, silt, and/or sediment near the point of discharge into a wetland or waterbody. If such deposition is occurring, the dewatering activity shall be stopped and the design of the discharge shall be changed to prevent reoccurrence;
- verifying the testing of subsoil and topsoil in agricultural and residential areas to measure compaction and determine the need for corrective action;
- advising the Chief Inspector when conditions (such as wet weather) make it advisable to restrict construction activities in agricultural areas;
- ensuring restoration of contours and topsoil;
- verifying that the soils imported for agricultural or residential use are noxious weed free certified;
- ensuring that temporary erosion controls are properly installed and maintained, daily if necessary;
- inspecting temporary erosion control measures at least on a daily basis in areas of active construction or equipment operation, on a weekly basis in areas with no construction or equipment operation, and within 24 hours of each 0.5 inch of rainfall; This responsibility may be transferred to field operations after construction is complete but before restoration is successful.
- ensuring the repair of all ineffective temporary erosion control measures within 24 hours of identification;

- keeping records of compliance with the environmental conditions of the (EM&CP and any certificates) and other federal or state environmental permits during active construction and restoration;
- establishing a program to monitor the success of restoration. Implementation of this program may be transferred to (Field Services) upon completion of construction and restoration activities;
- looking for evidence of contamination and, if found, cease activities in that area and notify the Environmental Health & Safety department and the Natural Resource Permitting group and wait for further instruction. If the contamination is determined to be hazardous, an experienced hazardous waste contractor will be mobilized to handle the waste; the hazardous waste contractor will follow a site-specific health and safety plan and standard operating procedures for working in hazardous environments, which is maintained by the Environmental Health & Safety department; and
- verifying the location of signs and visible flagging marking the boundaries of wetlands, waterbodies and other environmental sensitive areas.

### **C. Environmental Training**

The Engineering & Construction Team Leader assigned to the construction activity and/or the Columbia employee in responsible charge, will be responsible for assuring that the Environmental Inspector(s), other inspectors and any contractor's foreman have been trained in all environmental aspects of the activity, and fully understands the environmental conditions contained in the activity's EM&CP.

The Natural Resource Permitting group staff will conduct training for construction personnel when sensitive resources are present or when permit/certificate conditions mandate, or when requested by the Team Leader.

### **D. Contractor's Environmental Compliance Specialist (Environmental Foreman)**

For construction activities that utilize an outside contractor, the contractor will be required to provide at least one environmental compliance specialist. This specialist will become thoroughly familiar with Columbia's EM&CP for the activity. The specialist will be responsible for the contractor's efforts to correctly install and maintain environmental control devices and for construction in environmentally sensitive areas. Contractor's specialist will work in cooperation with Columbia's employees responsible for environmental compliance.

The Contractor's Environmental Foreman must be available at all times during the project and have the appropriate number of available employees to adequately implement the project's EM&CP.

### **E. Environmental Construction Management**



The Environmental Inspector and each functional inspector shall have the authority to stop work on a particular construction function to which they are assigned if it deviates from the environmental conditions of the activity's EM&CP. The deviation shall be reported immediately to the Columbia employee in responsible charge of the activity and the Environmental Inspector. The Columbia employee in responsible charge, the Engineering & Construction Team Leader and the Natural Resource Permitting group department will be responsible for the resolution of the deviation.

Stop work authority for the entire construction activity rests with the Columbia employee in responsible charge or the Engineering & Construction Team Leader.

The Natural Resource Permitting group may, from time to time, perform inspections of construction activities to review the implementation of the EM&CPs. The Natural Resource Permitting group will have stop work authority during these inspections should deviations from the activity's EM&CP occur. Any corrective actions that are required shall be taken as directed by the Natural Resources Permitting group.

#### **F. Environmental Variances**

Unapproved variances from an EM&CP and this ECS are not permitted. Any proposed variance from an EM&CP will require approval from the EM&CP preparer, prior to commencing the activity. The approval for a variance will be in writing. In instances where written approval is not practical (i.e., emergencies and weekends), verbal approval may be given provided that written confirmation is provided as soon as possible.

Any proposed variance from this ECS will require approval from the Natural Resource Permitting group prior to commencing the activity.

### **VII. EMERGENCY CONSTRUCTION**

In the event of an emergency, the Company employee in responsible charge will take such action as is necessary to contain the emergency giving due regard to minimizing environmental impact. In conjunction with other Columbia policies, the requirements contained in this ECS will be followed as close as possible.

<sup>1</sup> Will include all environmental and regulatory mandated surveys such as but not limited to, threatened and endangered species surveys, archeology surveys, wetland delineations etc.

<sup>2</sup> Deviations that involve measures different from those contained in this ECS will only be permitted by written approval from the Natural Resource Permitting group. The Natural Resource Permitting group may be required to obtain written approval from the Director of the Office of Pipeline Regulation (OPR) (Federal Energy Regulatory Commission), or his/her designee, unless specifically required in writing by another Federal, state, or Native American land management agency for the portion of the project on its land. The Natural Resource Permitting group shall coordinate the filing of

other agency requirements with the Secretary of the Commission (Secretary). This filing shall be prior to construction.

## VIII. DEFINITION OF TERMS\*

**AGRICULTURAL LANDS:** Permanent or rotated croplands, hayfields, and pastures.

**COLUMBIA:** Columbia Gas Transmission Corporation

**COE:** U.S. Army Corps of Engineers

**CONSTRUCTION WORK AREA:** Construction work areas include permanent and temporary ROW, contractor's yards, pipe and materials storage yards, staging areas, and access roads.

**ECS:** Environmental Construction Standards

**ENVIRONMENTAL INSPECTOR:** The Inspector responsible for environmental compliance on a construction project.

**EPA:** Environmental Protection Agency

**FWS:** U.S. Fish and Wildlife Service

**EM&CP:** Environmental Management and Construction Plan

**EXCEPTIONAL VALUE WATER(S):** A stream or waterbody which constitutes an outstanding national, State, regional or local resource, such as waters of national, State or county parks or forests, or waters which are used as a source of unfiltered potable water supply, or waters of wildlife refuges or State game lands, or waters which have been characterized by the Fish Commission as "Wilderness Trout Streams." and other waters of substantial recreational or ecological significance.

**FINAL GRADING:** Includes returning the construction work area as closely as practical to its original contour, redistributing conserved topsoil, soil compaction testing in agricultural lands, and installing final interceptor diversions.

**HIGH QUALITY STREAM:** A cold water fishery or significant warm water fishery as designated by a state resource agency.

**IMMEDIATE:** Without interval of time; "right now".

**INSPECTOR:** Collectively: the Chief Inspector, Environmental Inspector, Utility Inspector, or any other inspector assigned to do an environmental task.

**INTERMITTENT WATERBODY:** A waterbody channel which generally carries water in the spring or immediately after a rain event; designated on topographic maps and environmental construction drawings with a broken line.

**INTERMEDIATE WATERBODY:** A waterbody greater than 10 feet wide at the water's edge at the time of construction but less than or equal to 100 feet wide.

**LOW-GROUND-WEIGHT:** Construction equipment that is designed “specifically for” or “frequently used in” areas where compaction and sinking is to be minimized. This equipment can be less than 5 lbs/in<sup>2</sup> or contain wider tracks than the standard minimum size width tracks for the model equipment to be used.

**MAJOR WATERBODY:** A waterbody greater than 100 feet wide at the water's edge at the time of construction.

**MINOR WATERBODY:** A waterbody less than or equal to 10 feet wide at the water's edge at the time of construction.

**MSDS:** Material Safety Data Sheet

**NRCS:** Natural Resource Conservation Service

**NOISE SENSITIVE AREA:** Includes residences, schools, churches, cemeteries, hospitals, farms, camping facilities and outdoor amphitheaters and playgrounds.

**ORV:** Off-road vehicle.

**PERENNIAL WATERBODY:** A waterbody which generally flows all year in years of normal rainfall; waterbody level is generally lowest in the fall, highest in the spring; designated with a solid line on topographic maps and environmental construction drawings.

**PROMPTLY:** By the end of the work day.

**RESTORATION:** Includes fertilizing, liming, disking, seeding and mulching, and crimping mulch.

**RIVER:** A waterbody which is 100 feet wide or more.

**ROW:** Right-of-way.

**SCARIFY:** To make shallow cuts into the soil surface. This should be accomplished with a disk, rake, tracked equipment (grousers) or other suitable means.

**SEDIMENT FILTER DEVICE:** Properly embedded silt fence or staked bales (Figures 7 & 8).

**SPCC:** Spill Prevention Control and Countermeasure Plan

**STEEP SLOPE:** Slope of 33% or greater.

**TEMPORARY STABILIZATION:** Includes installing temporary interceptor diversions and sediment filter devices, mulching critical areas and at times, seeding to hold soil in place until final grading and restoration can be accomplished.

**UPLAND CONSTRUCTION:** All areas which are not waterbodies, rivers, streams, or wetlands.

**WATERBODY:** Includes any natural or artificial waterbody, river, or drainage with perceptible flow at the time of crossing, and other permanent waterbodies such as ponds and lakes.

**WETLAND:** An area of special concern with soils prone to holding water for long periods of time, generally also characterized by distinctive plants such as rushes, sedges, cattails, or certain trees. Includes any area that satisfies the requirements of the current Federal methodology for identifying and delineating wetlands.

\*Includes all grammatical variations of each term.

**IX. TABLES**

**TABLE 2A  
SEED MIX REQUIREMENTS FOR UPLAND ROW AND WATERBODY CROSSINGS**

<b>Type</b>		<b>Rate (lbs/acre)</b>
Seed <sup>1</sup>	Orchard Grass and/or Tall Fescue <sup>2</sup>	20
	Birdsfoot-trefoil (Empire) <sup>3</sup>	7
	Annual Rye	10
Fertilizer	10-10-10 (or equivalent)	600 <sup>4</sup>
Agricultural Lime		4000
Mulch	Hay or Straw	4000
<p><sup>1</sup> Pure live seed within 12 months of testing.</p> <p><sup>2</sup> If tall fescue is used, plant endophyte-free certified seed.</p> <p><sup>3</sup> Legumes to be inoculated by manufacturer's recommendations, if not available legumes are to be inoculated at 4 times recommended rate for conventional methods. 10 times recommended rate for hydro seeding.</p> <p><sup>4</sup> Where wood chips are spread, additional nitrogen (12 to 15 lbs per ton of chips) will be spread.</p>		

**TABLE 2B  
SEED MIX FOR TEMPORARY STABILIZATION**

<b>Type</b>		<b>Rate (lbs/acre)</b>
Seed	Annual Rye	40
Mulch	Hay or Straw	6000

**TABLE 2C  
SEED MIX REQUIREMENTS IN WETLANDS**

<b>Type</b>		<b>Rate (lbs/acre)</b>
Seed*	Annual Rye	40
<p>* Annual Rye is used as a temporary revegetative measure until indigenous plants re-establish cover. A monitoring program will be in effect to insure adequate cover is established.</p>		

X. FIGURES

A. Figure 1 – Typical Upland Pipeline Construction Sequence

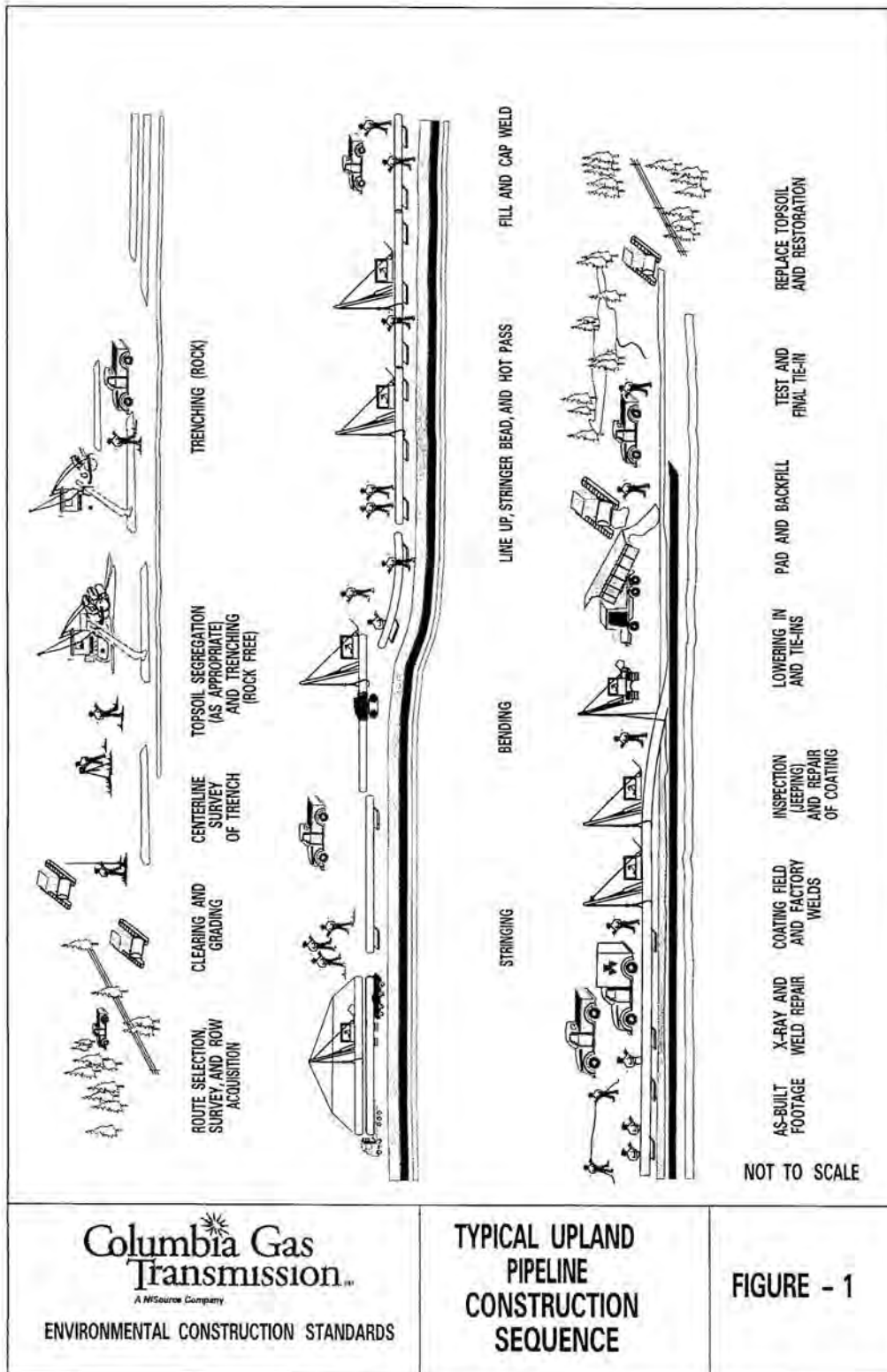

B. Figure 2 – Typical 75ft. Construction Right-of-Way

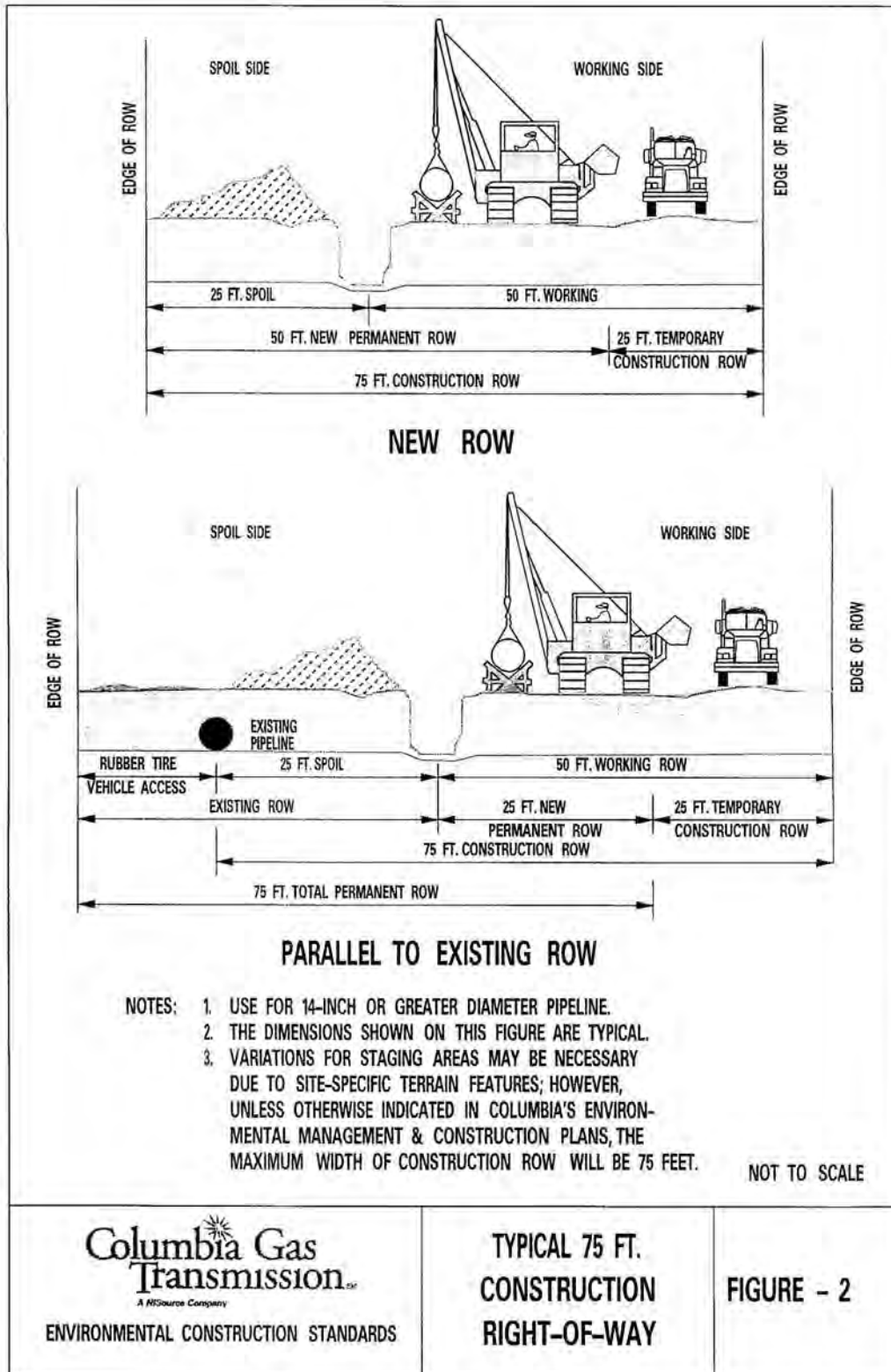

C. Figure 3 – Typical 50ft. Construction Right-of-Way

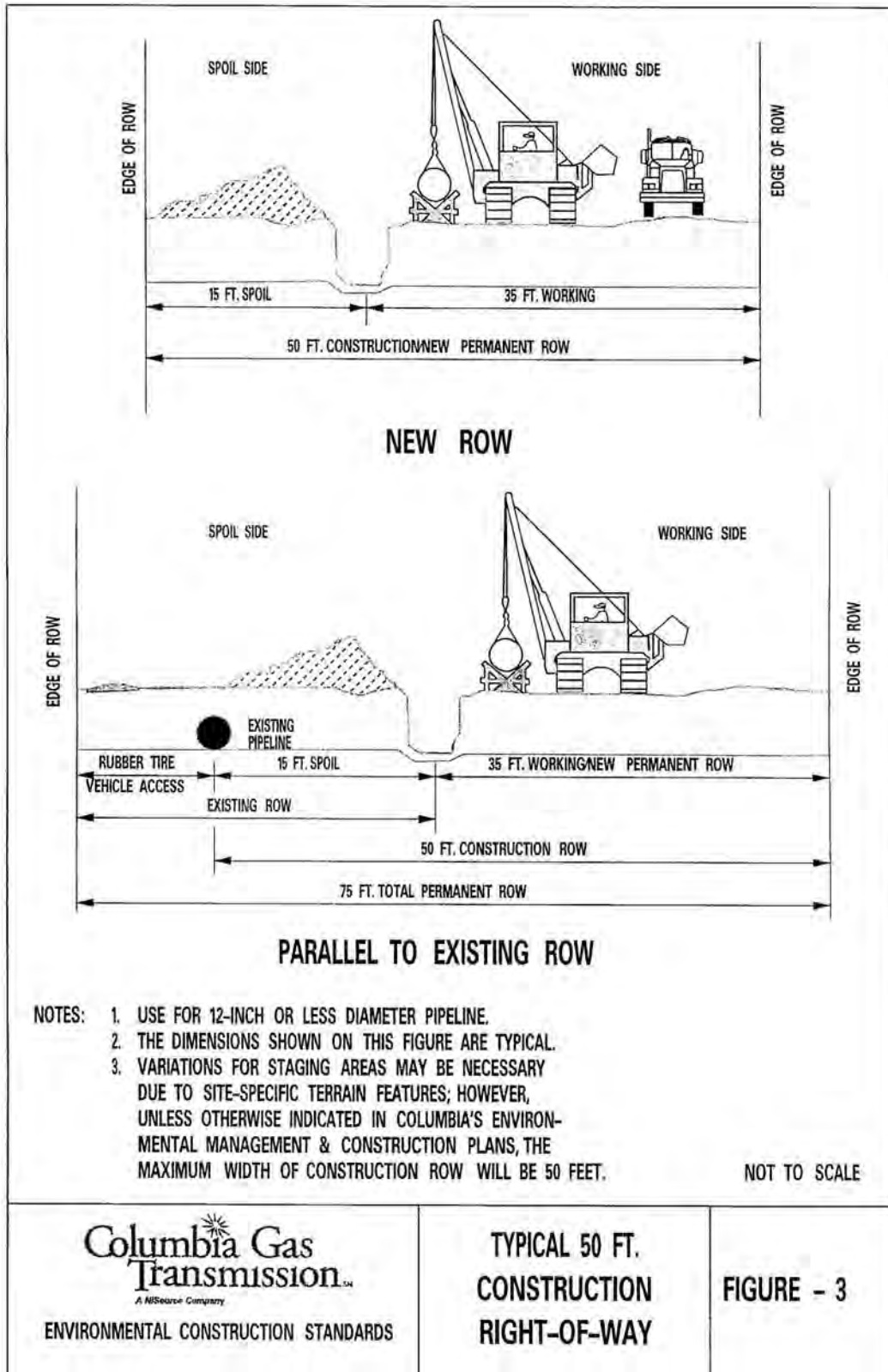



D. Figure 4 – Temporary Construction Gate

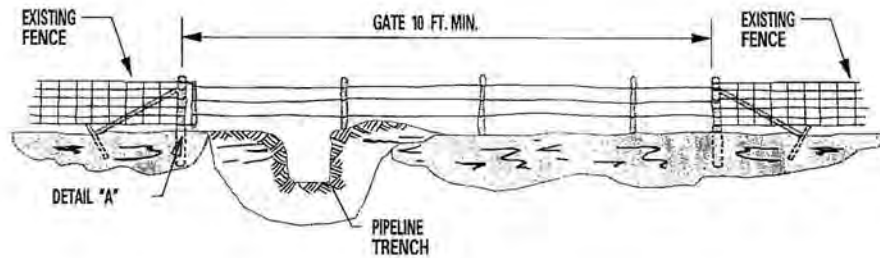
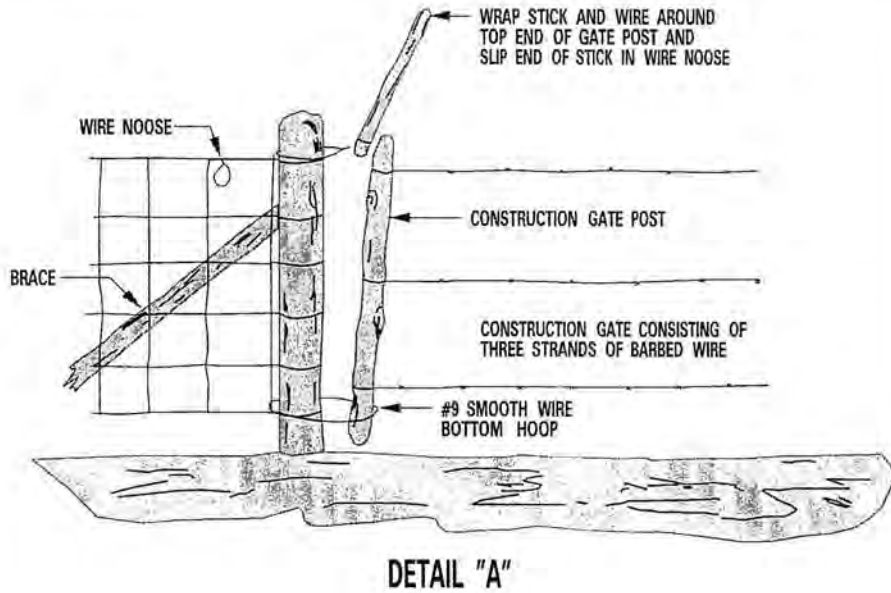

- NOTES:
1. IF EXISTING FENCE POSTS ARE STEEL "T" BAR TYPE, THEN REMOVE THE STEEL "T" BAR POST ON BOTH SIDES OF THE GATE OPENING AND REPLACE WITH TEMPORARY WOODEN POSTS, BRACED AS SHOWN.
  2. SUITABLE SUBSTITUTES FOR THE STICK AND WIRE GATE FASTENER ARE PERMISSIBLE.

NOT TO SCALE

**Columbia Gas**  
**Transmission**<sup>SM</sup>  
A NISource Company

ENVIRONMENTAL CONSTRUCTION STANDARDS

**TEMPORARY  
 CONSTRUCTION  
 GATE**

**FIGURE - 4**

E. Figure 5 – Typical Soil Conservation

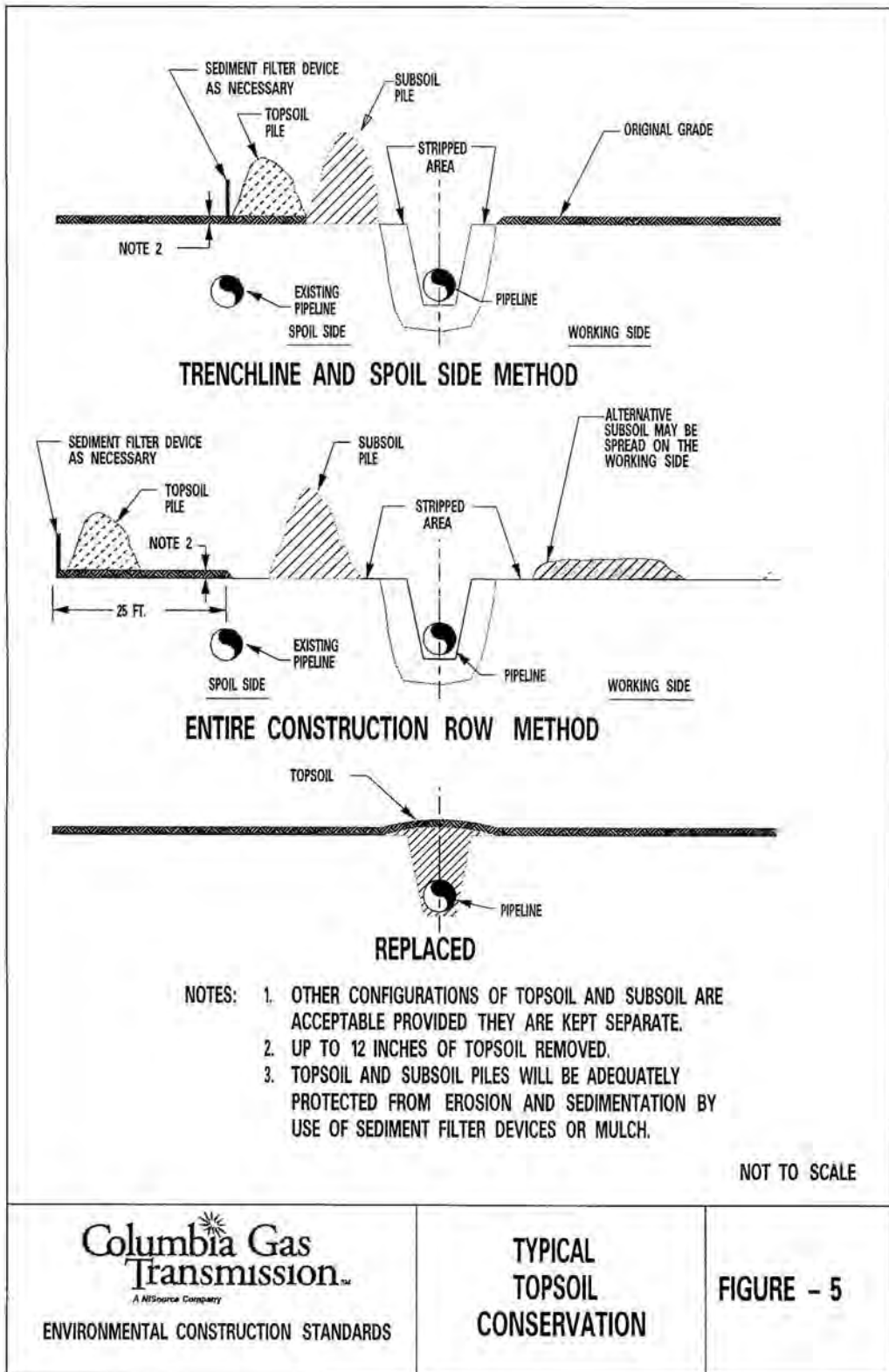

F. Figure 6A - Interceptor Diversions/Slope Breakers

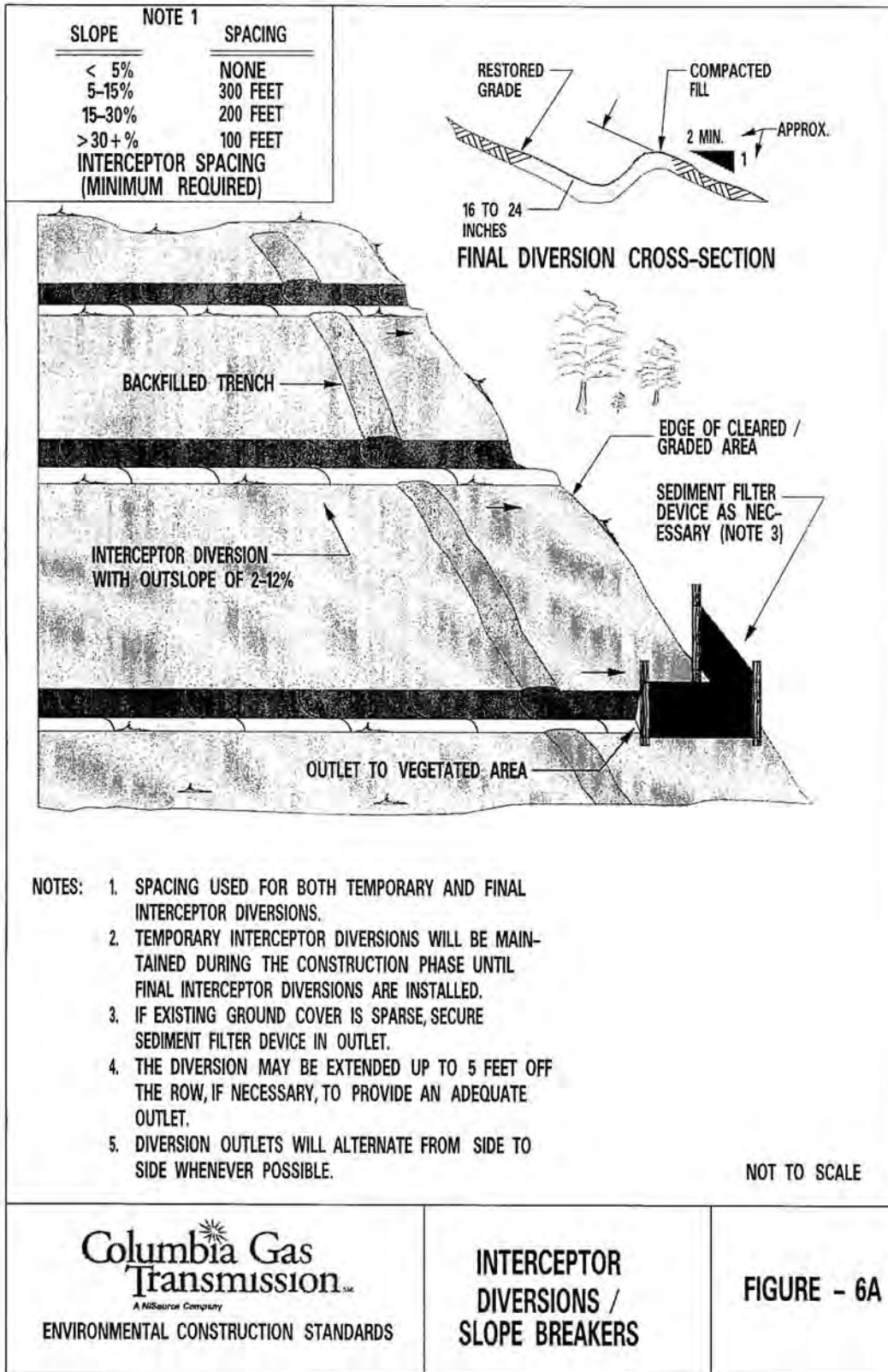

**Columbia Gas Transmission**  
A NBSource Company  
ENVIRONMENTAL CONSTRUCTION STANDARDS

**INTERCEPTOR  
DIVERSIONS /  
SLOPE BREAKERS**

**FIGURE - 6A**

**G. Figure 6B – Interceptor Diversions**

INTERCEPTOR DIVERSIONS /SLOPE BREAKERS

Interceptor diversions are the most common and effective device used for erosion control on construction ROW. During construction, temporary diversions are installed to control water on the graded ROW. During restoration final diversions are installed to protect the ROW from erosion until the vegetation reestablishes on the disturbed areas.

Temporary diversions are generally made by building a curb 8 to 14 inches high across the ROW. The curbs are shaped to allow passage of construction equipment and inspector vehicles. The diversion should have a gradient of 2%– 12%, and must drain either into the trench or off the ROW. Where water is directed off the ROW, the outlet will be protected by a sediment filter device or heavy vegetation. Temporary diversions may be broken down by construction equipment during the workday, but will be restored by the end of each day. Temporary diversions will be spaced along the ROW in accordance with Figure 6A. The actual number of temporary diversions may vary from that of final diversions because the construction ROW's artificial grade may reduce the slope. Temporary diversions may be constructed out of silt fence, staked hay or straw bales or sand bags with the Environmental Inspectors approval. Position the outfall of each temporary slope breaker to prevent sediment discharge into wetland, waterbodies, or other sensitive areas.

Final diversions typically consist of a curb 16 to 24 inches high below a shallow swale. The curb is constructed of compacted earth fill with side slopes of 2:1 or flatter to allow passage of maintenance equipment. The diversions should extend across the entire ROW and drain water with a 2% to 12% gradient. The outlets of final diversions are stabilized with sediment filter devices, rock, brush, or heavy vegetation. Final diversions will be spaced along the ROW in accordance with Figure 6A (or as shown on the Environmental Construction Drawings), and will tie into existing diversions where present. In places where final grade creates side slopes or slopes which break in more than one direction, diversion installation may need to vary to create an outslope of 2% to 12% which will carry water off the ROW.

Alternative diversion construction may be used in areas where an earthen diversion is impractical. In these instances, temporary diversions may be constructed with sediment filter devices as noted above.

H. Figure 7 – Sediment Filter Device Silt Fencing

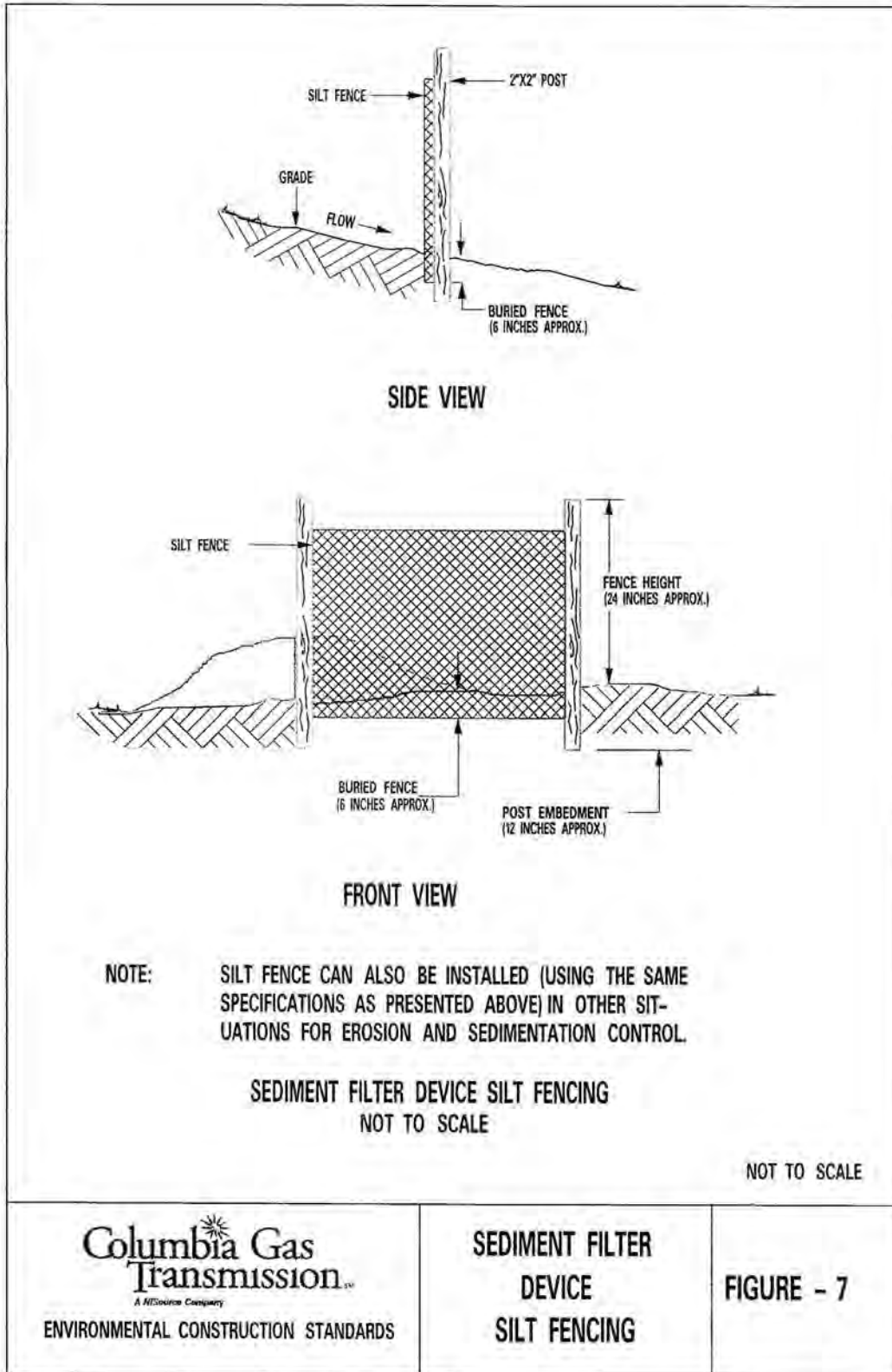

I. Figure 8 – Sediment Filter Device Staked Bales

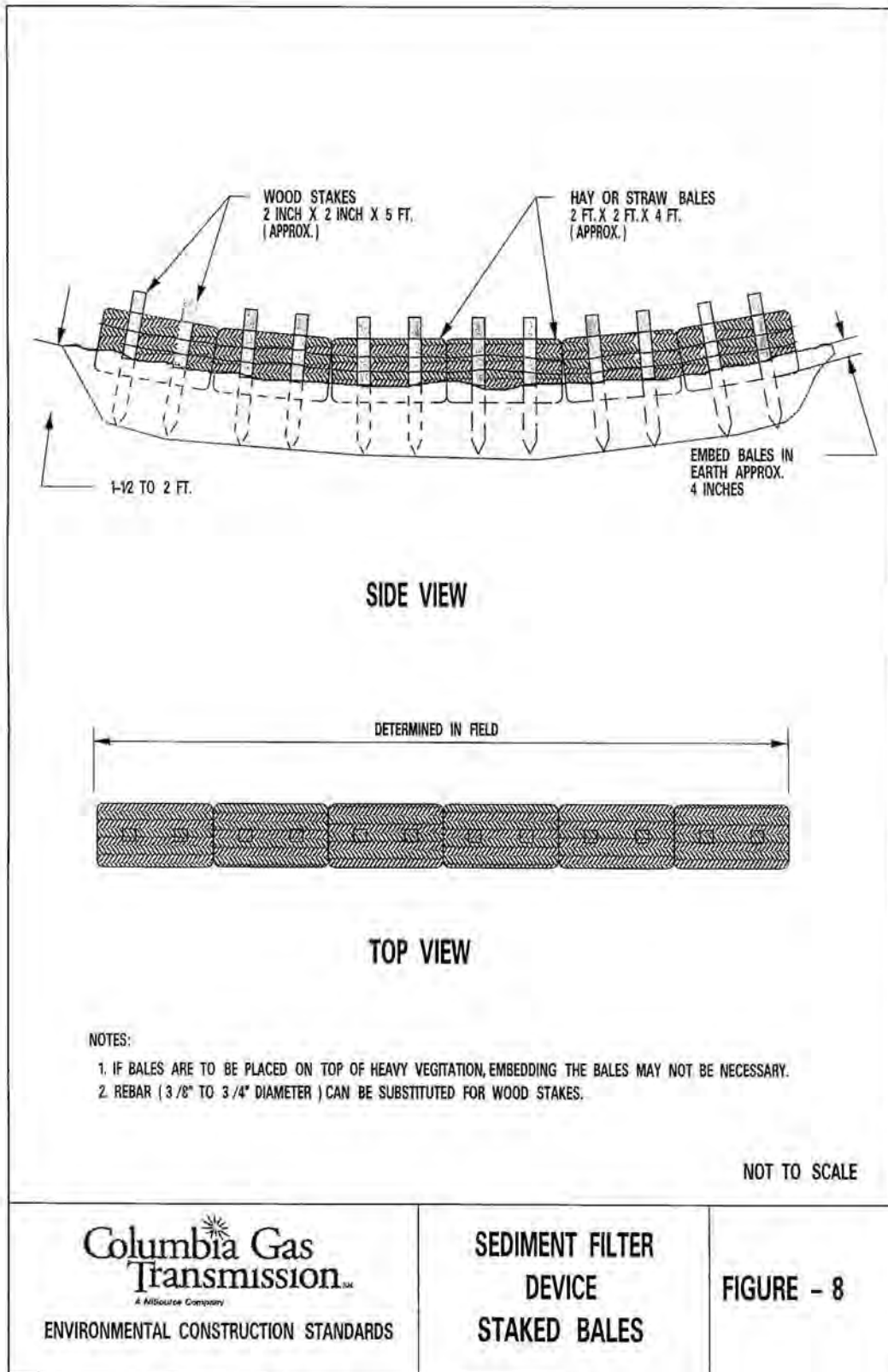

J. Figure 9 – Temporary Road Entrance Rock Pads

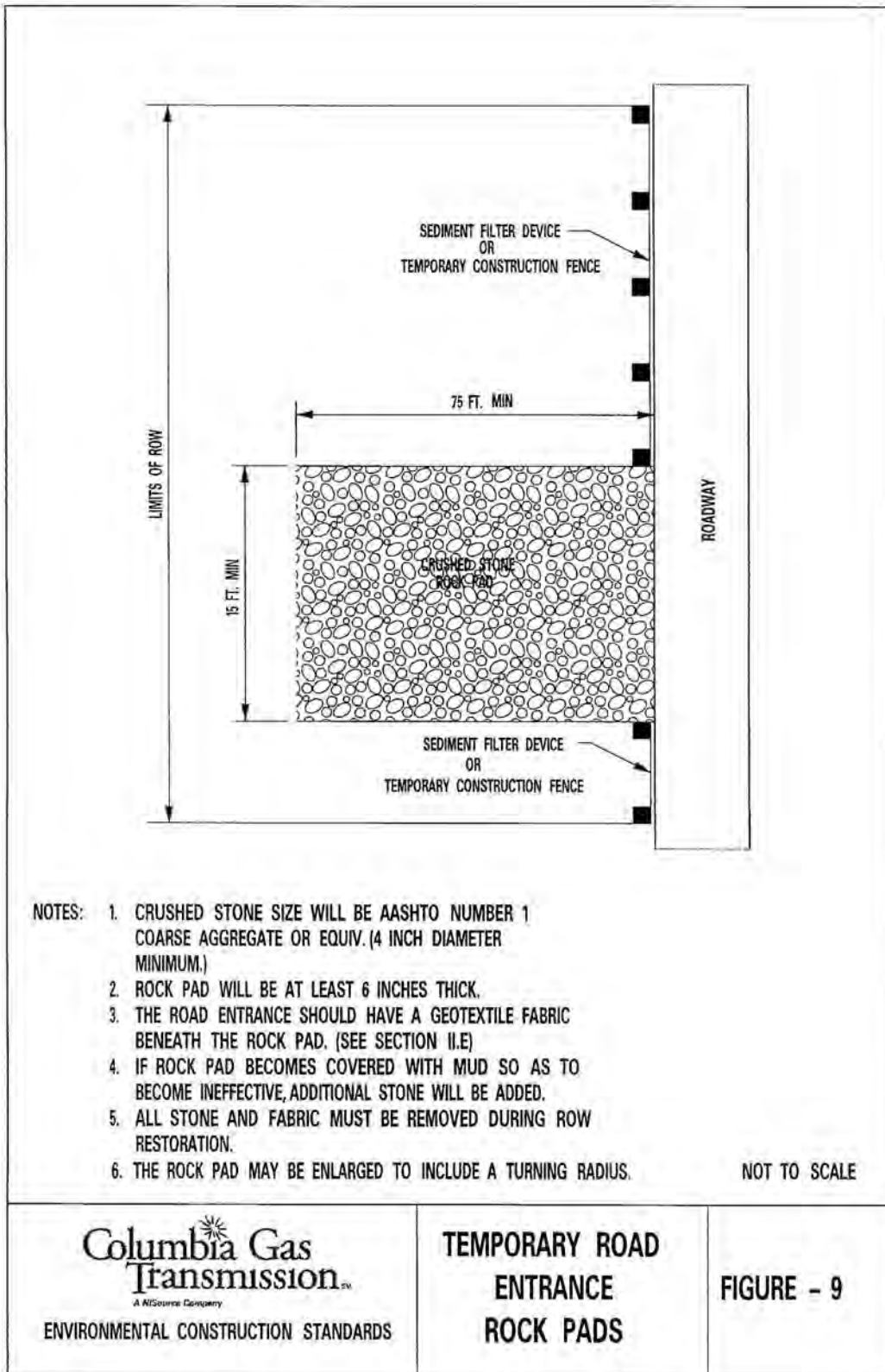

K. Figure 10 – Temporary Road Entrance Terra-Mats

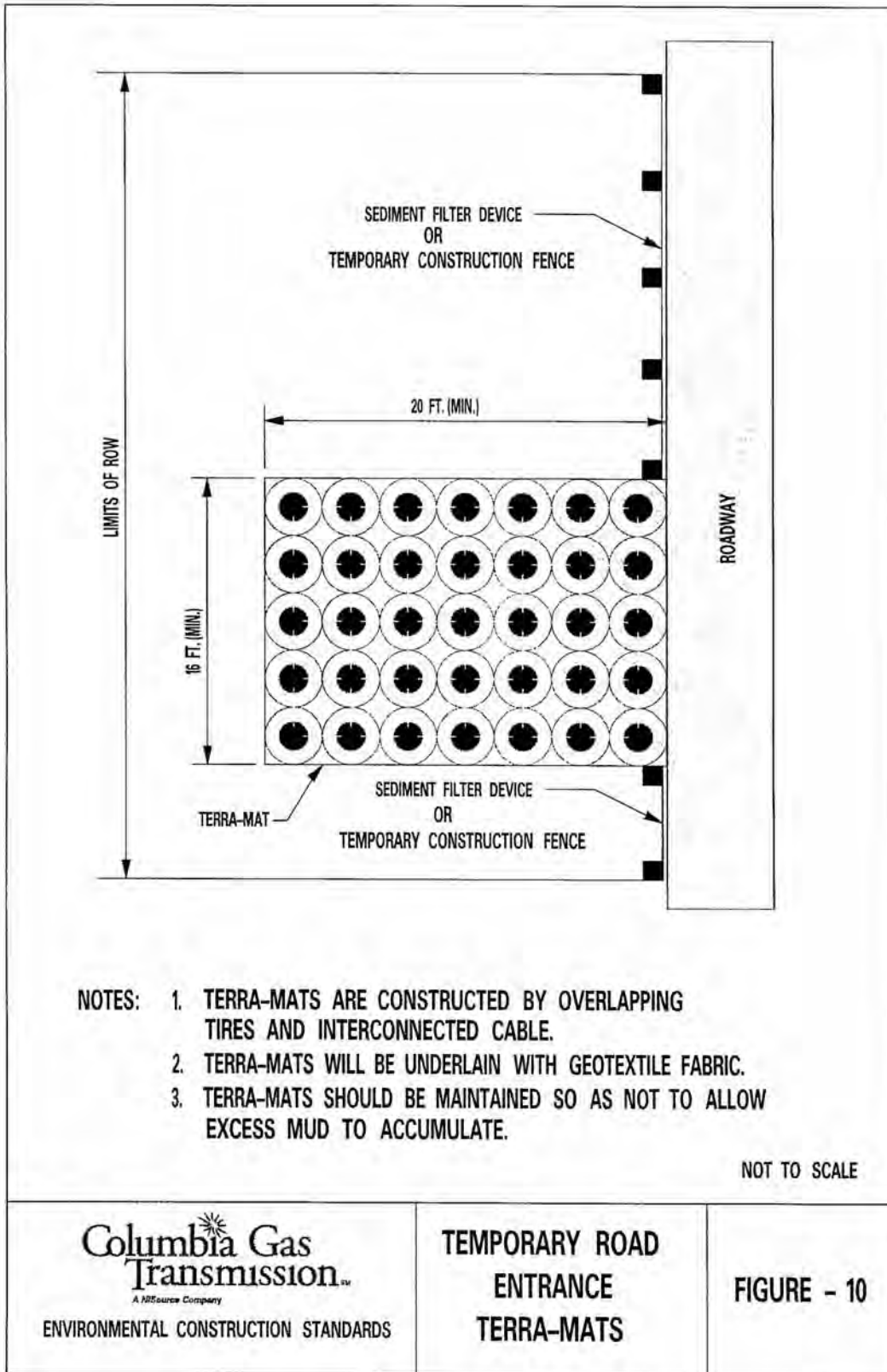



L. Figure 11 – Temporary Road Entrance Board Road

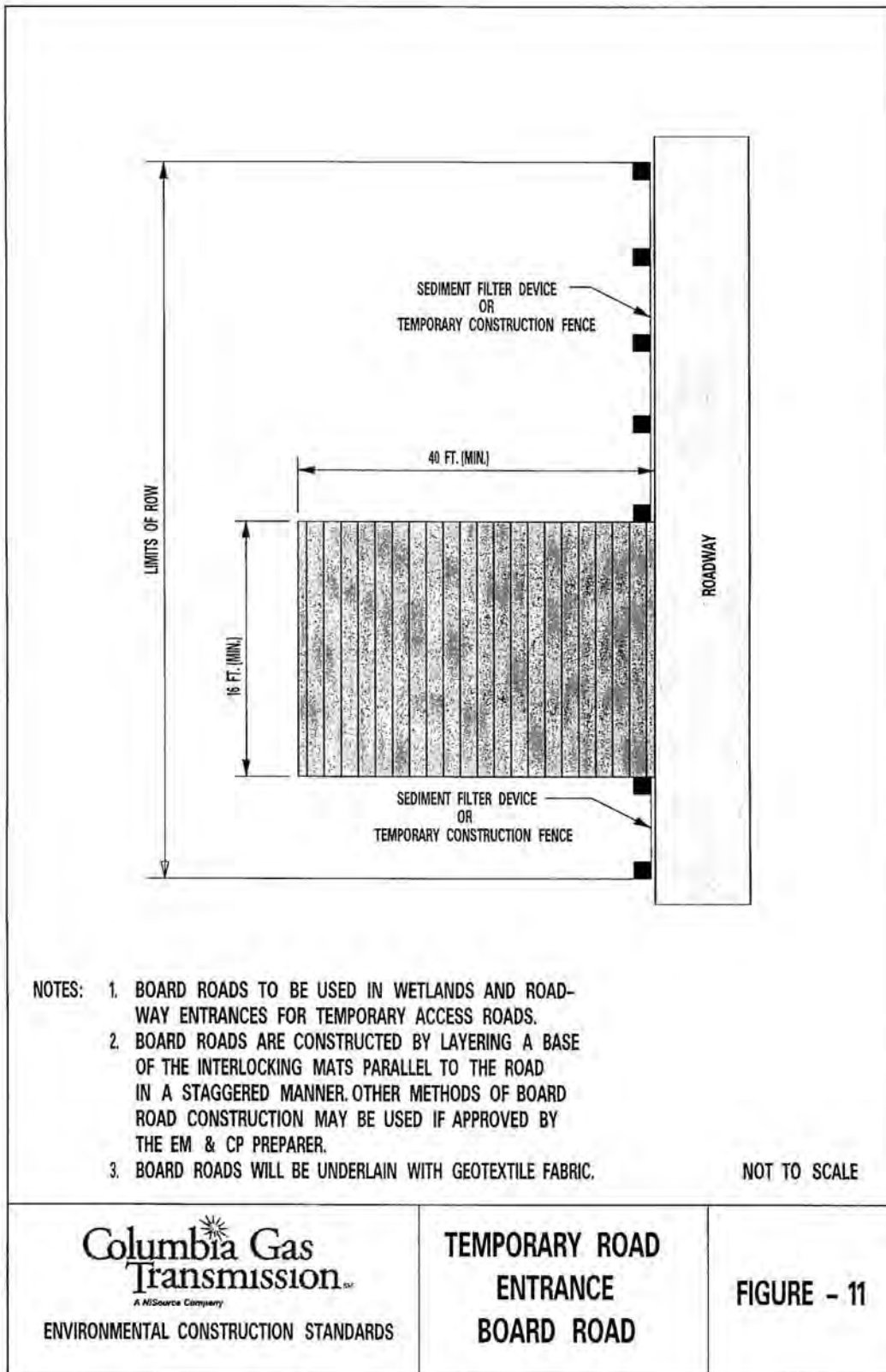

M. Figure 12 – Typical Erosion Control Measures at Road Crossings

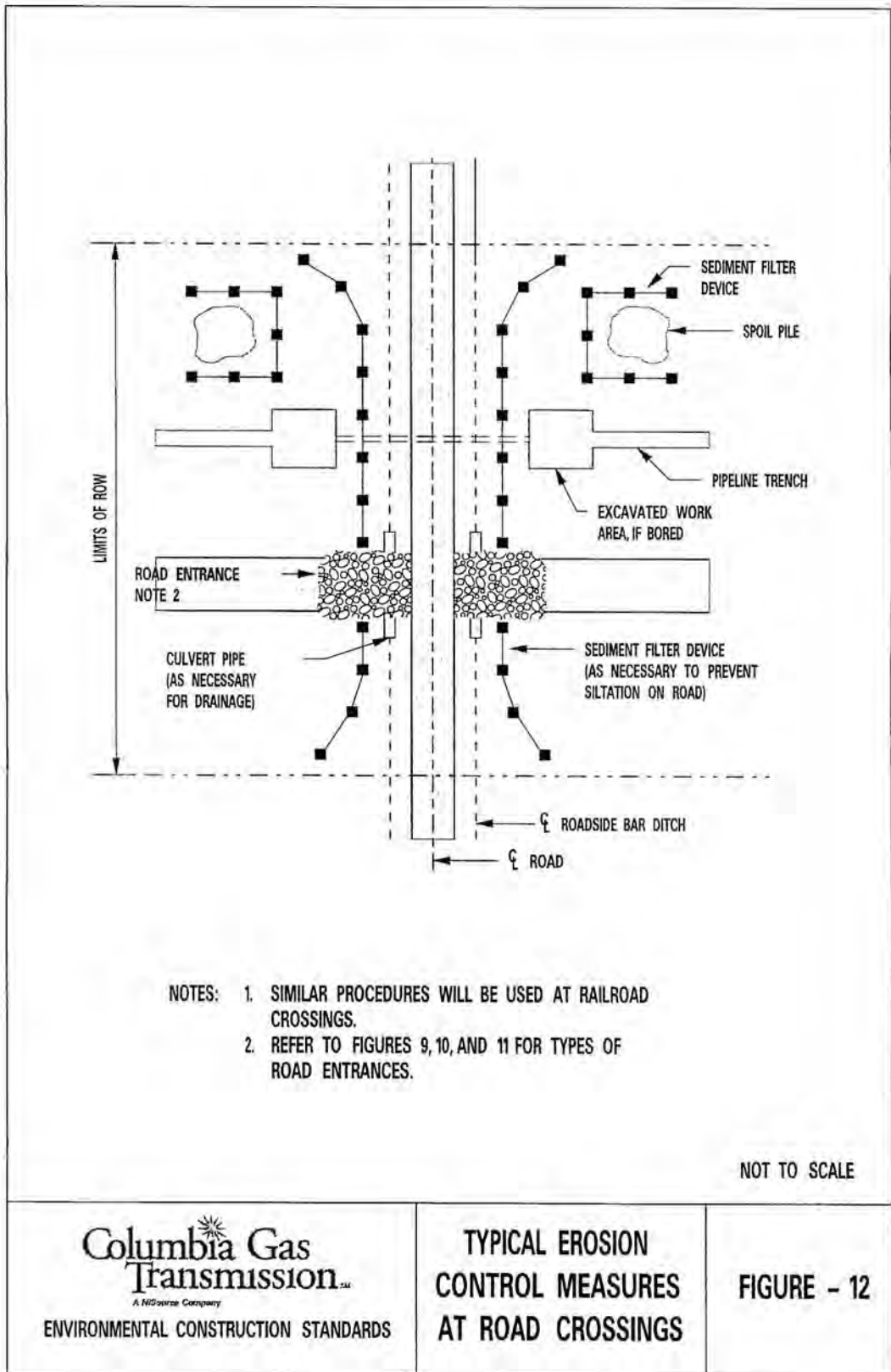

N. Figure 13 – Trenchline Barriers and Breakers

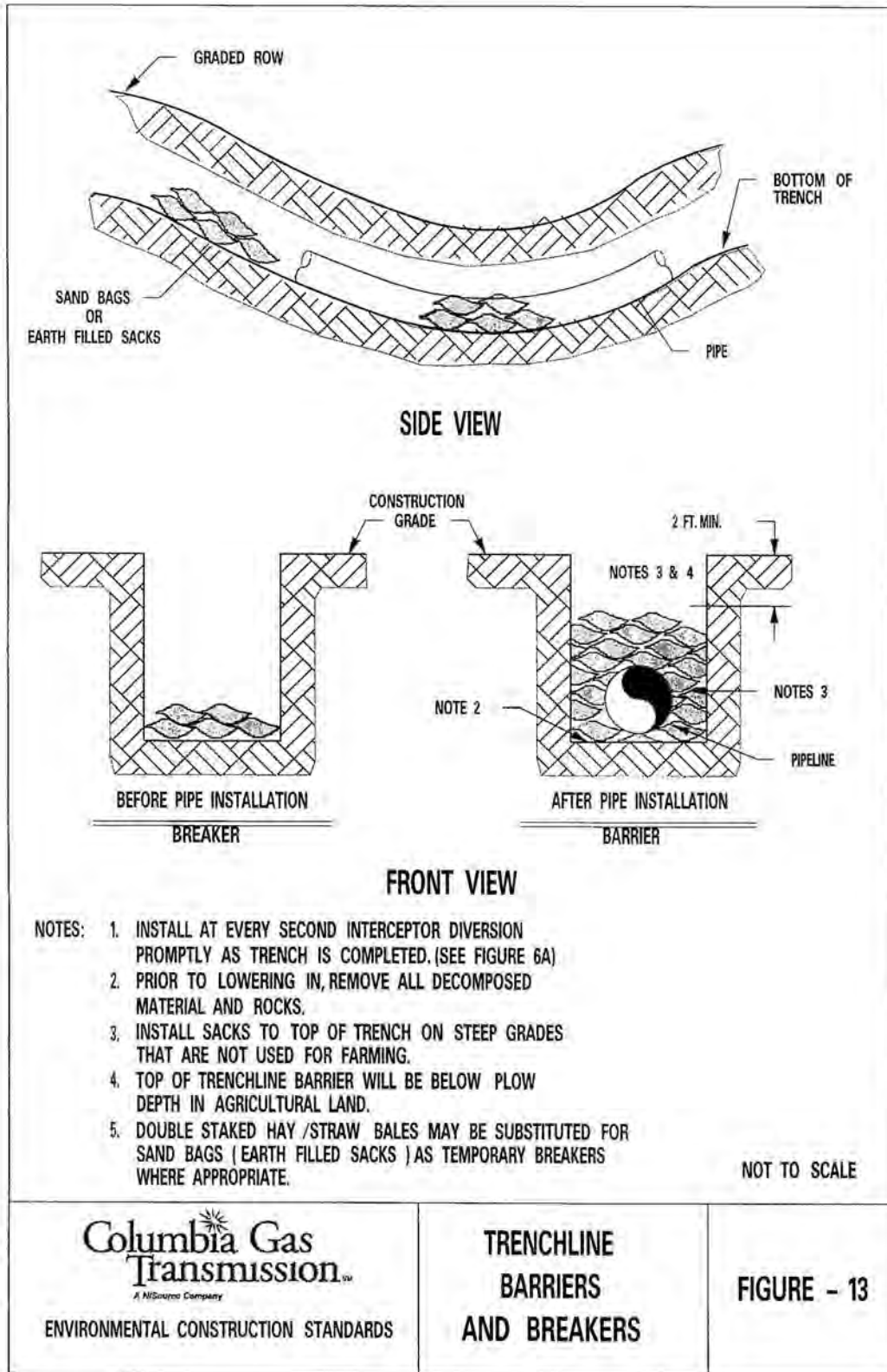

**Columbia Gas Transmission**  
A NiSource Company

ENVIRONMENTAL CONSTRUCTION STANDARDS

**TRENCHLINE  
BARRIERS  
AND BREAKERS**

**FIGURE - 13**

O. Figure 14A – Sediment Trap

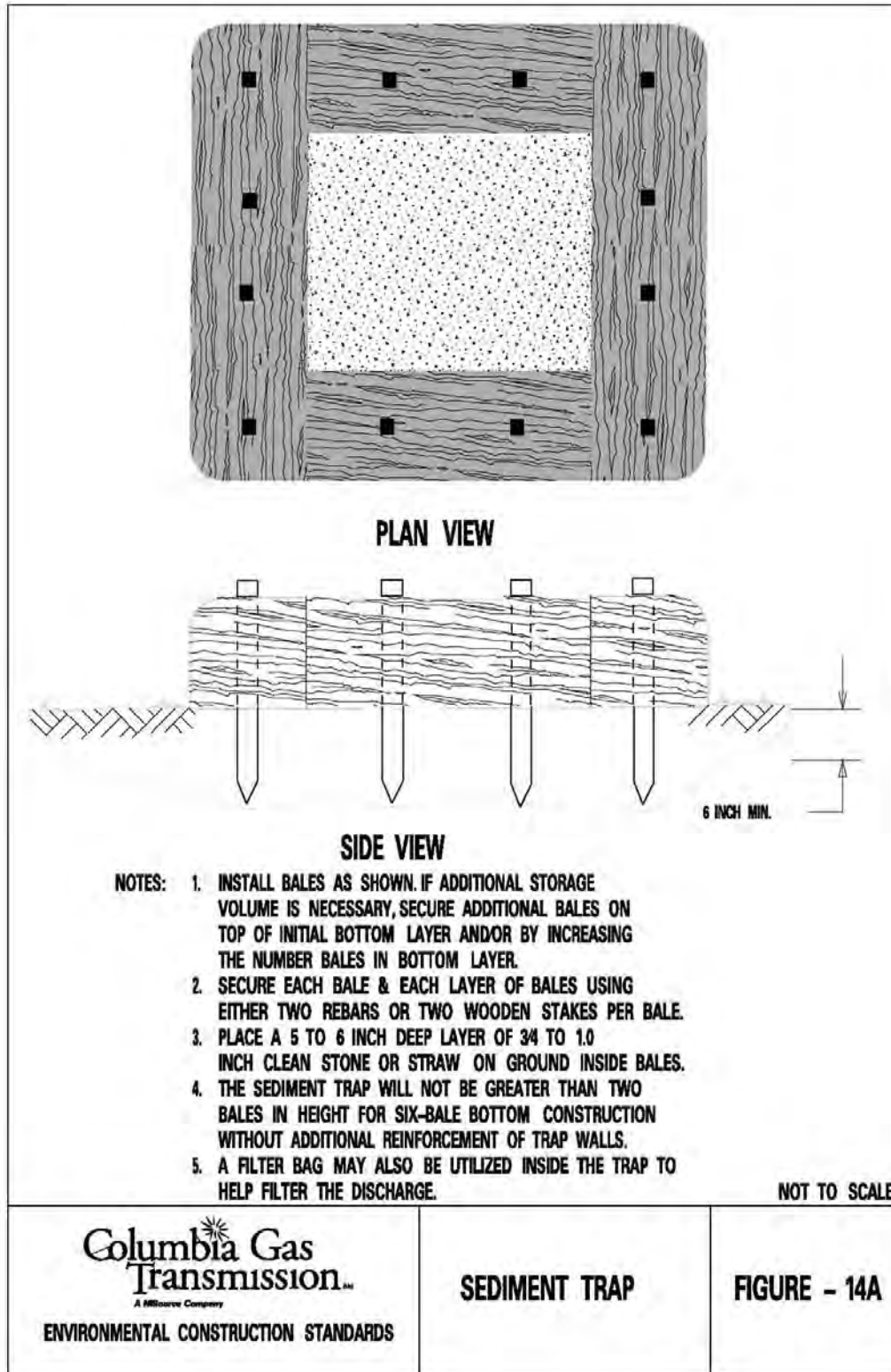

P. Figure 14B – Filter Bag

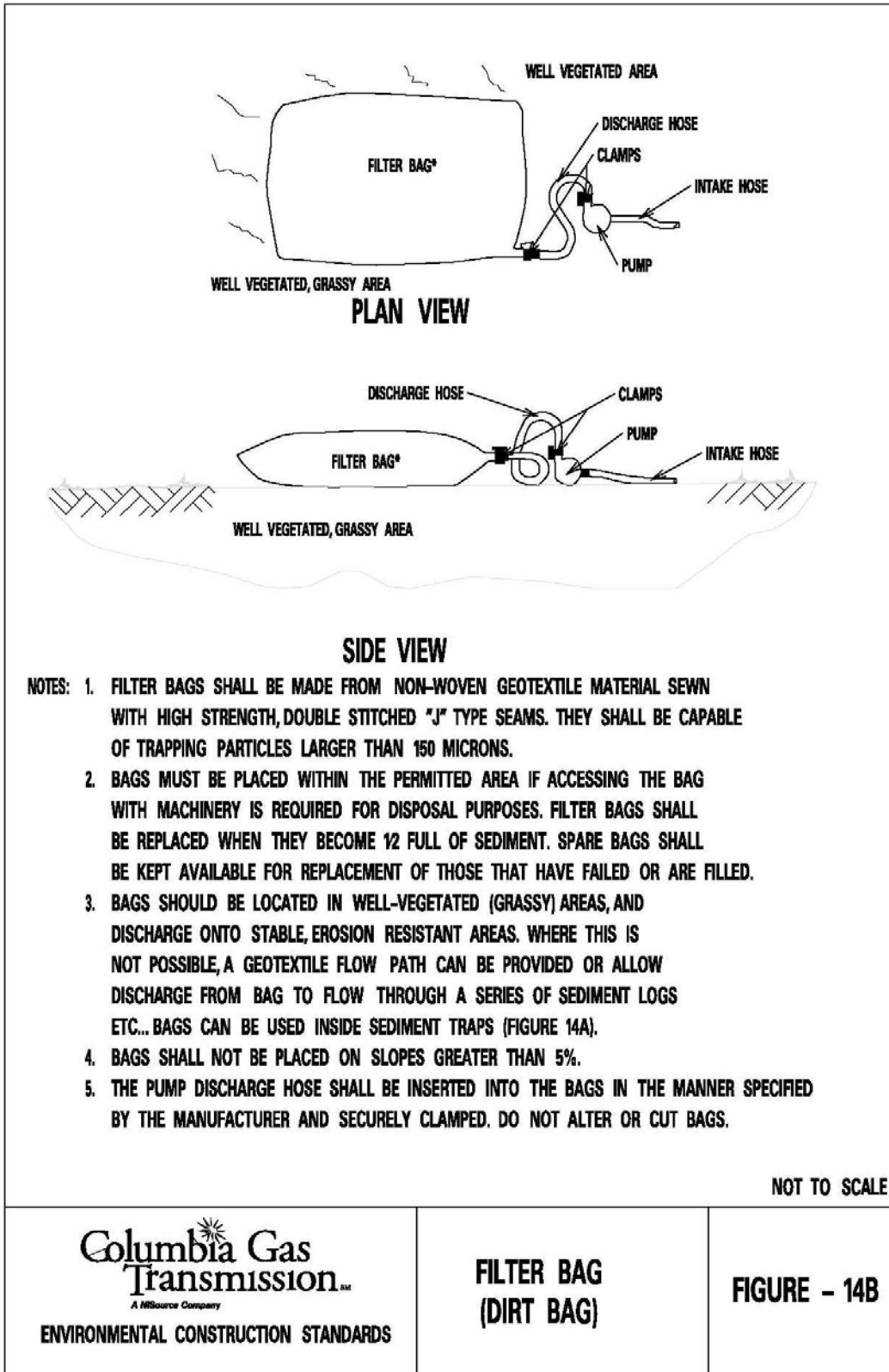

**Q. Figure 15 – Field Tile Replacement Methods**

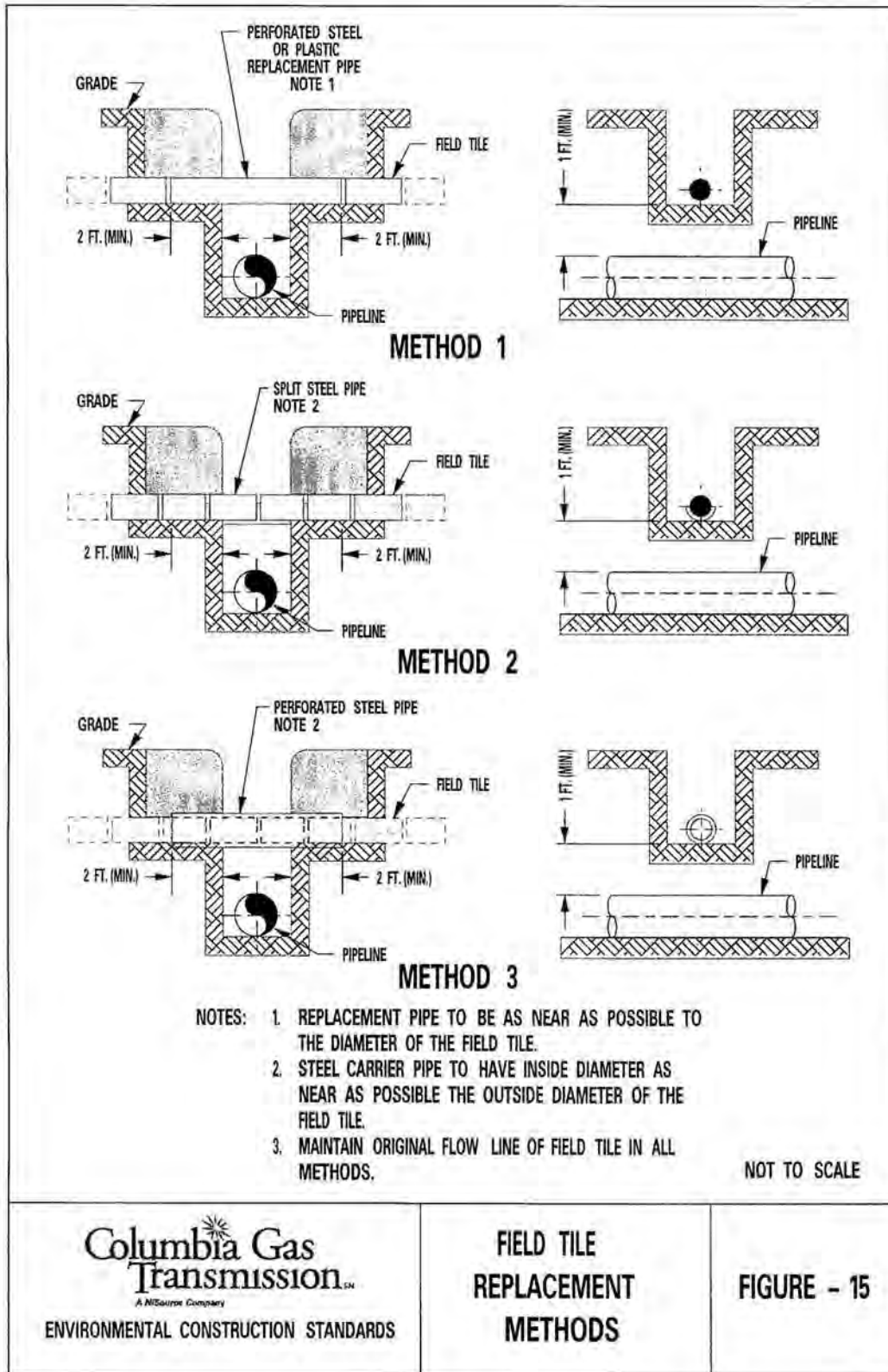

R. Figure 16 – Erosion Control Blanket

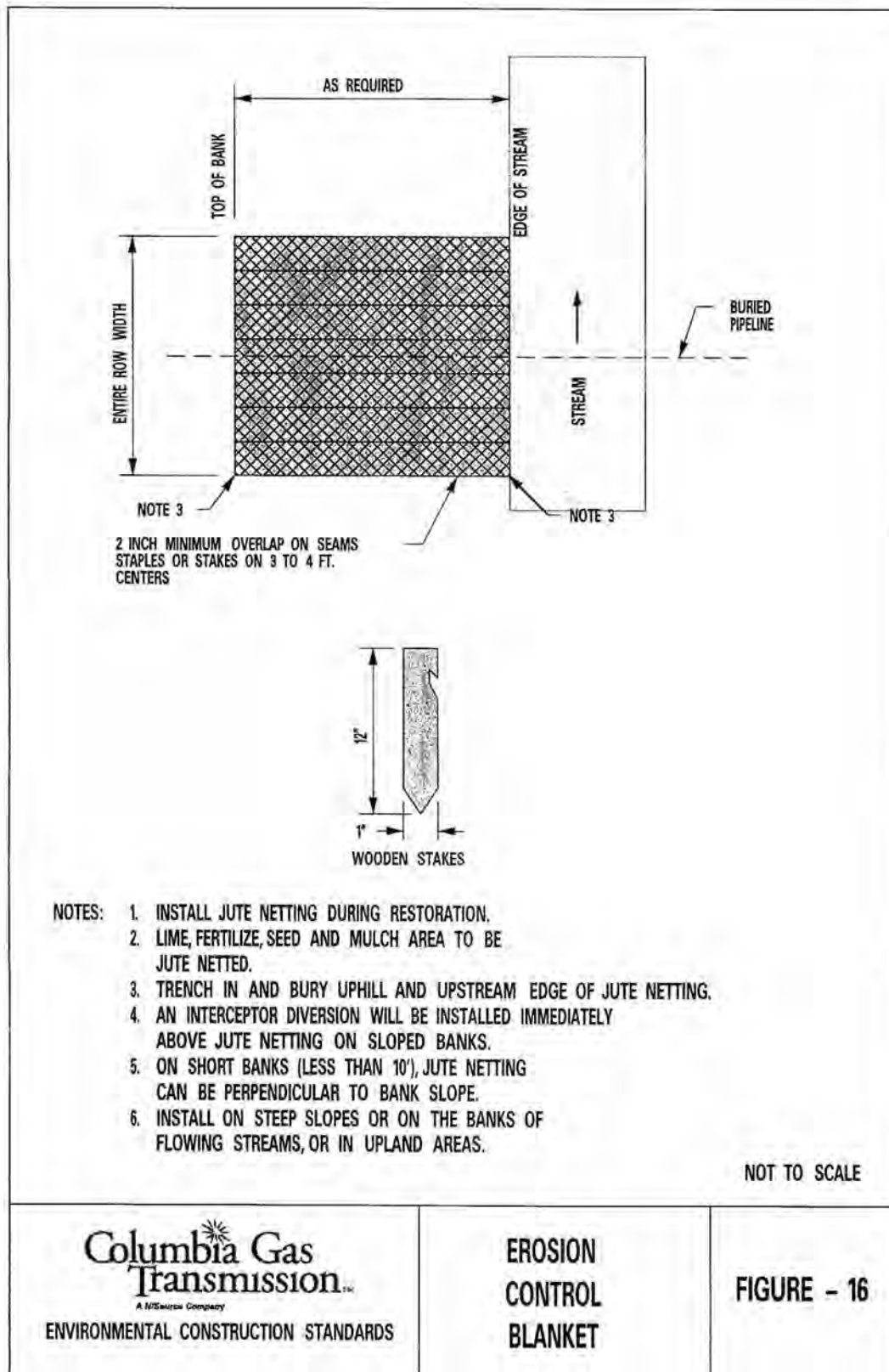

S. Figure 17 – Typical Stream Crossing Intermittent Streams

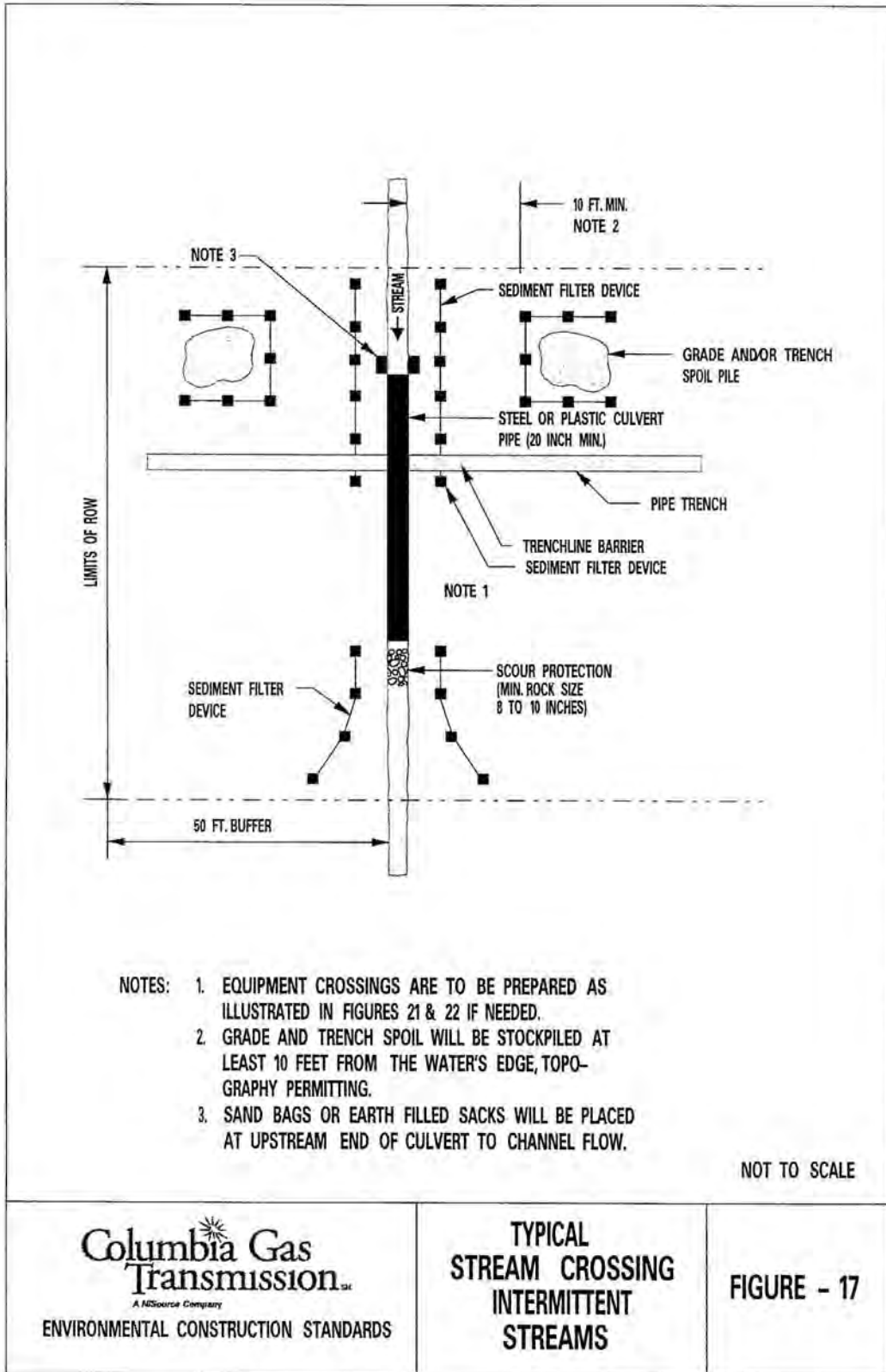



T. Figure 18 – Typical Stream Crossing Dry-Ditch

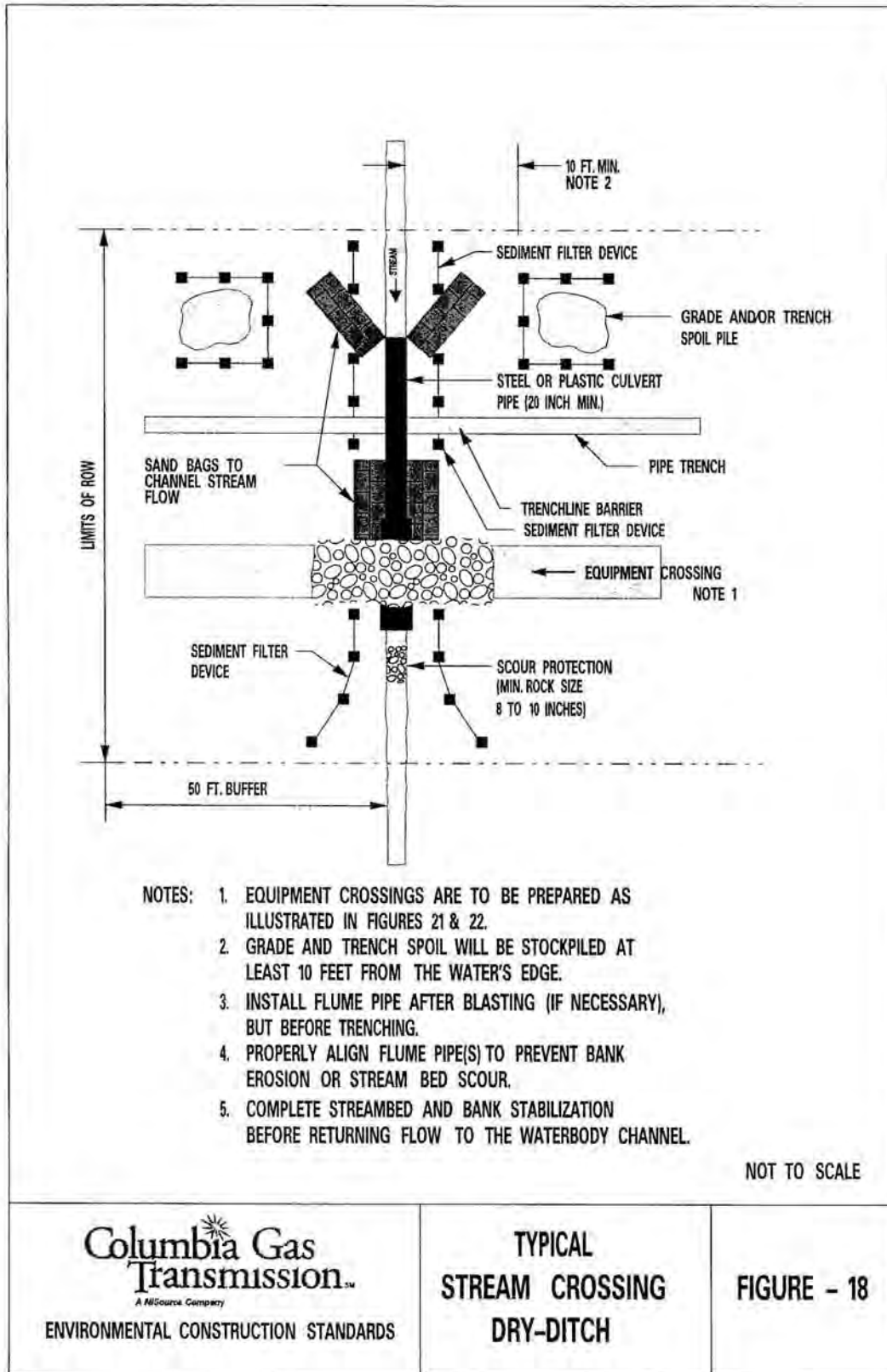

**Columbia Gas Transmission**  
A NGSource Company  
ENVIRONMENTAL CONSTRUCTION STANDARDS

**TYPICAL  
STREAM CROSSING  
DRY-DITCH**

**FIGURE - 18**

U. Figure 19 – Typical Stream Crossing Dam and Pump

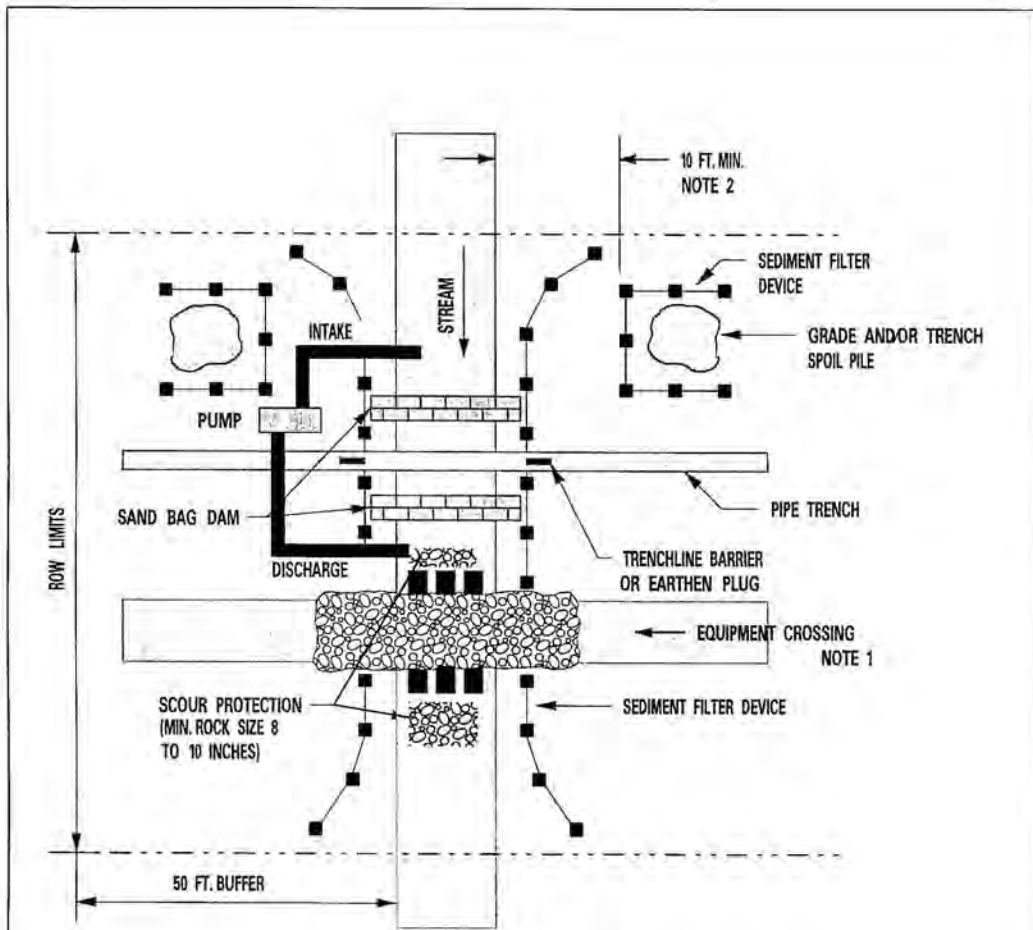

- NOTES:
1. EQUIPMENT CROSSINGS ARE TO BE INSTALLED AS ILLUSTRATED IN FIGURES 21 OR 22.
  2. GRADE AND TRENCH SPOIL WILL BE STOCKPILED AT LEAST 10 FEET FROM THE WATERS' EDGE, TOPOGRAPHY PERMITTING.
  3. PUMP INTAKES WILL BE SCREENED. PREVENT STREAMBED SCOUR AT DISCHARGE.
  4. SUFFICIENT PUMP CAPACITY WILL BE USED TO MAINTAIN STREAM FLOW AT ALL TIMES UNTIL BACKFILL AND REMOVAL OF SANDBAG DAM.
  5. BACKUP PUMPS (AS SAME NUMBER AND CAPACITY AS ACTIVE PUMPS ) WILL BE READILY AVAILABLE IN WORKING CONDITION ON SITE AT CROSSING.
  6. CONSTRUCT DAMS WITH MATERIAL THAT PREVENT SEDIMENT AND OTHER POLLUTANTS FROM ENTERING THE WATERBODY.
  7. MONITOR THE DAM AND PUMPS TO ENSURE PROPER OPERATIONS THROUGHOUT THE WATERBODY CROSSING.

NOT TO SCALE

<p style="text-align: center;">   <b>Columbia Gas Transmission</b>  <small>A NISource Company</small>  <b>ENVIRONMENTAL CONSTRUCTION STANDARDS</b> </p>	<p><b>TYPICAL STREAM CROSSING DAM AND PUMP</b></p>	<p><b>FIGURE - 19</b></p>
--	--	---------------------------

V. Figure 20 – Typical Stream Crossing Wet-Ditch

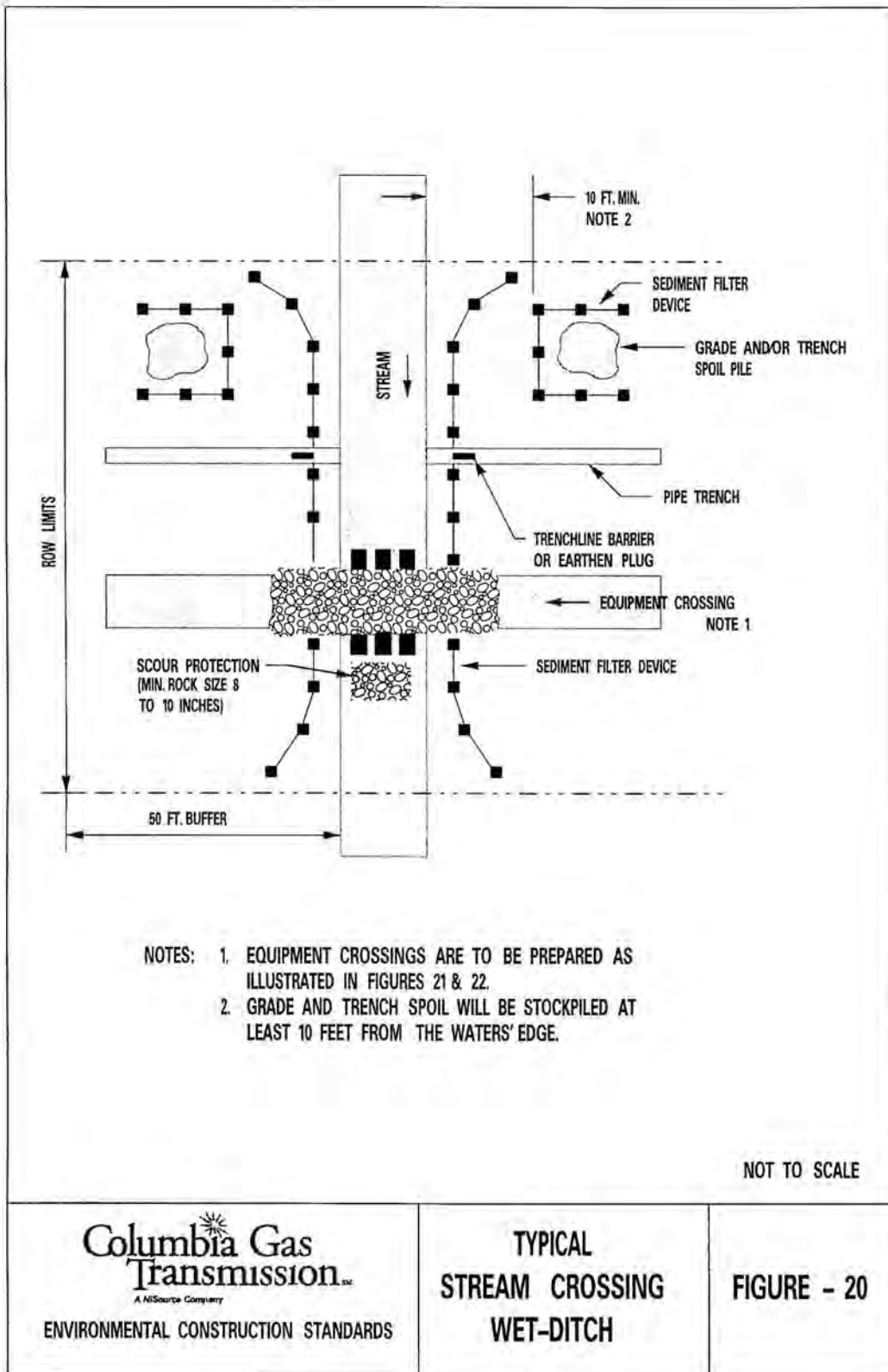

W. Figure 21 – Temporary Equipment Crossing Culvert and Stone

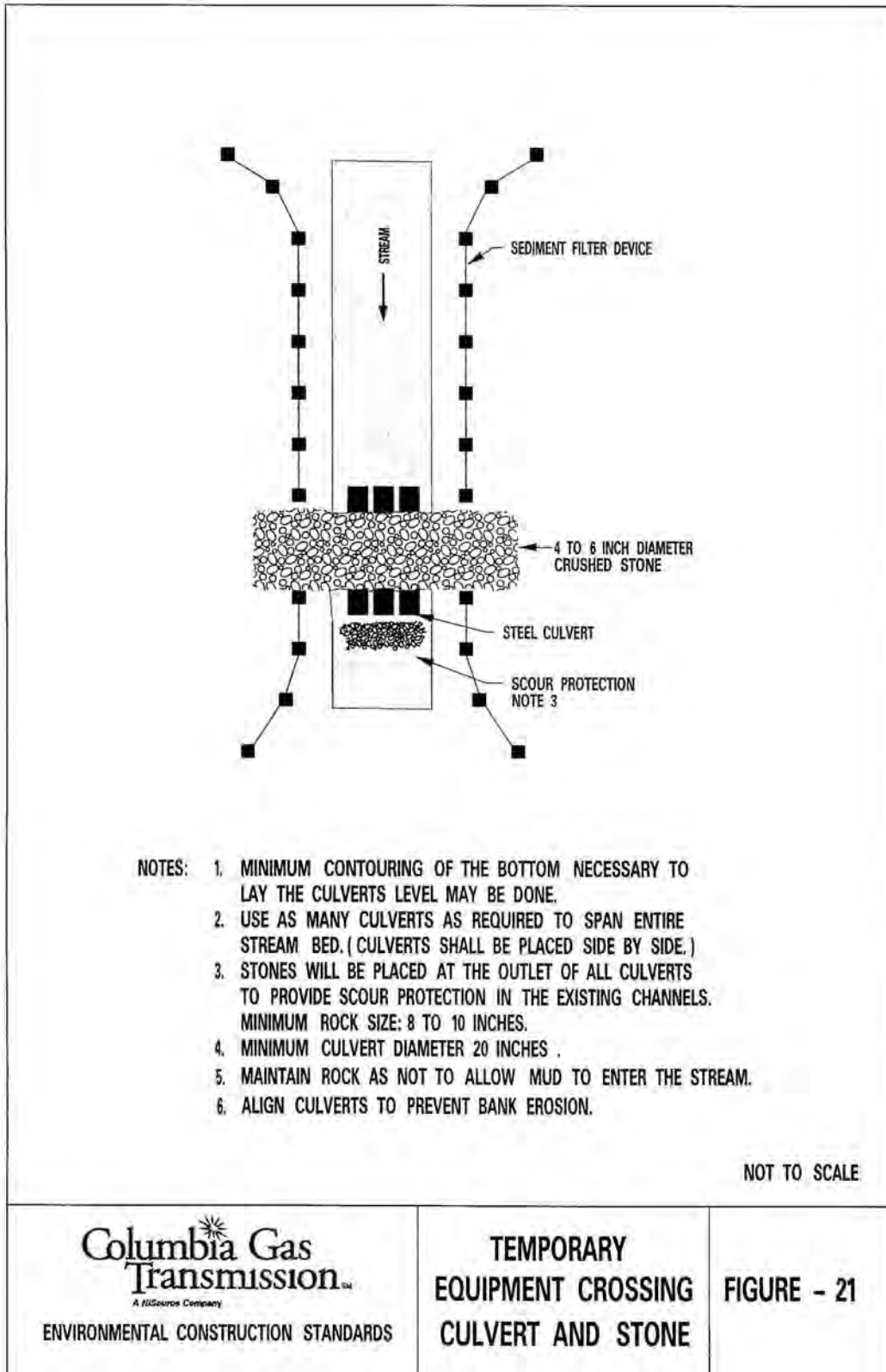

X. Figure 22 – Temporary Equipment Crossing Equipment Pads

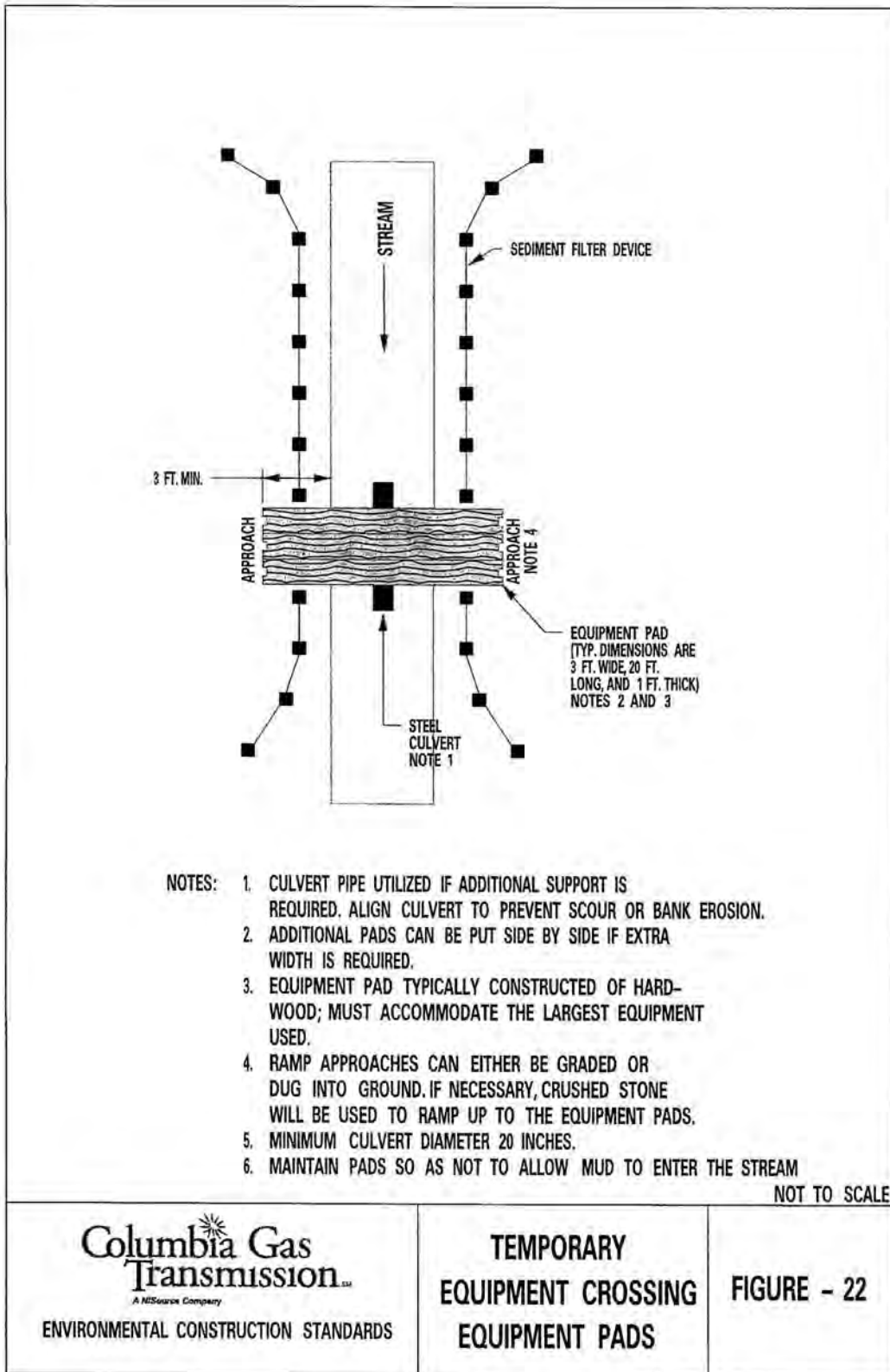

Y. Figure 23 – Typical Wetland Crossing

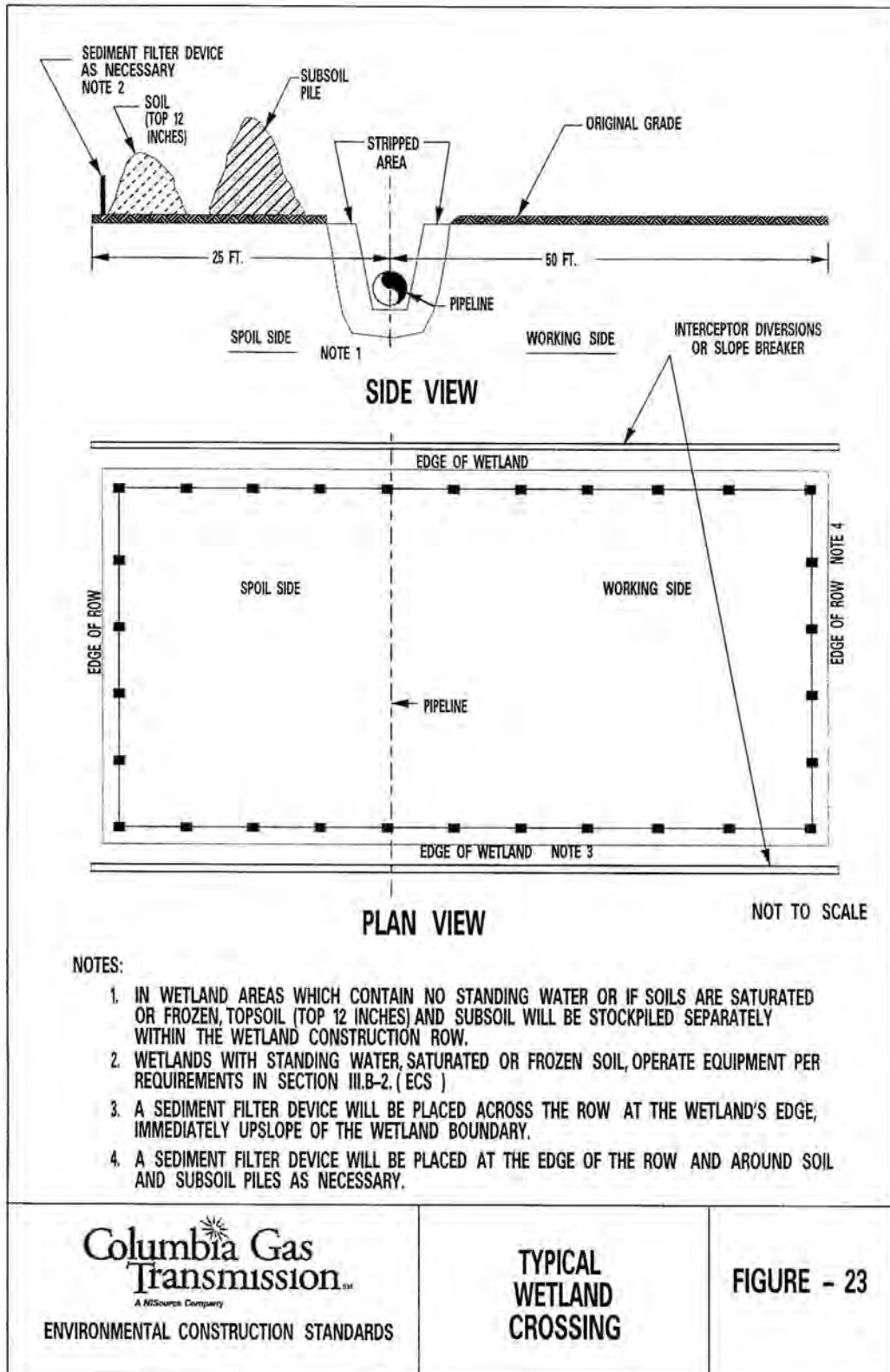

**Columbia Gas Transmission**  
A NISource Company

ENVIRONMENTAL CONSTRUCTION STANDARDS

**TYPICAL  
WETLAND  
CROSSING**

**FIGURE - 23**

Z. Figure 24 – ROW Maintenance Perennial Streams

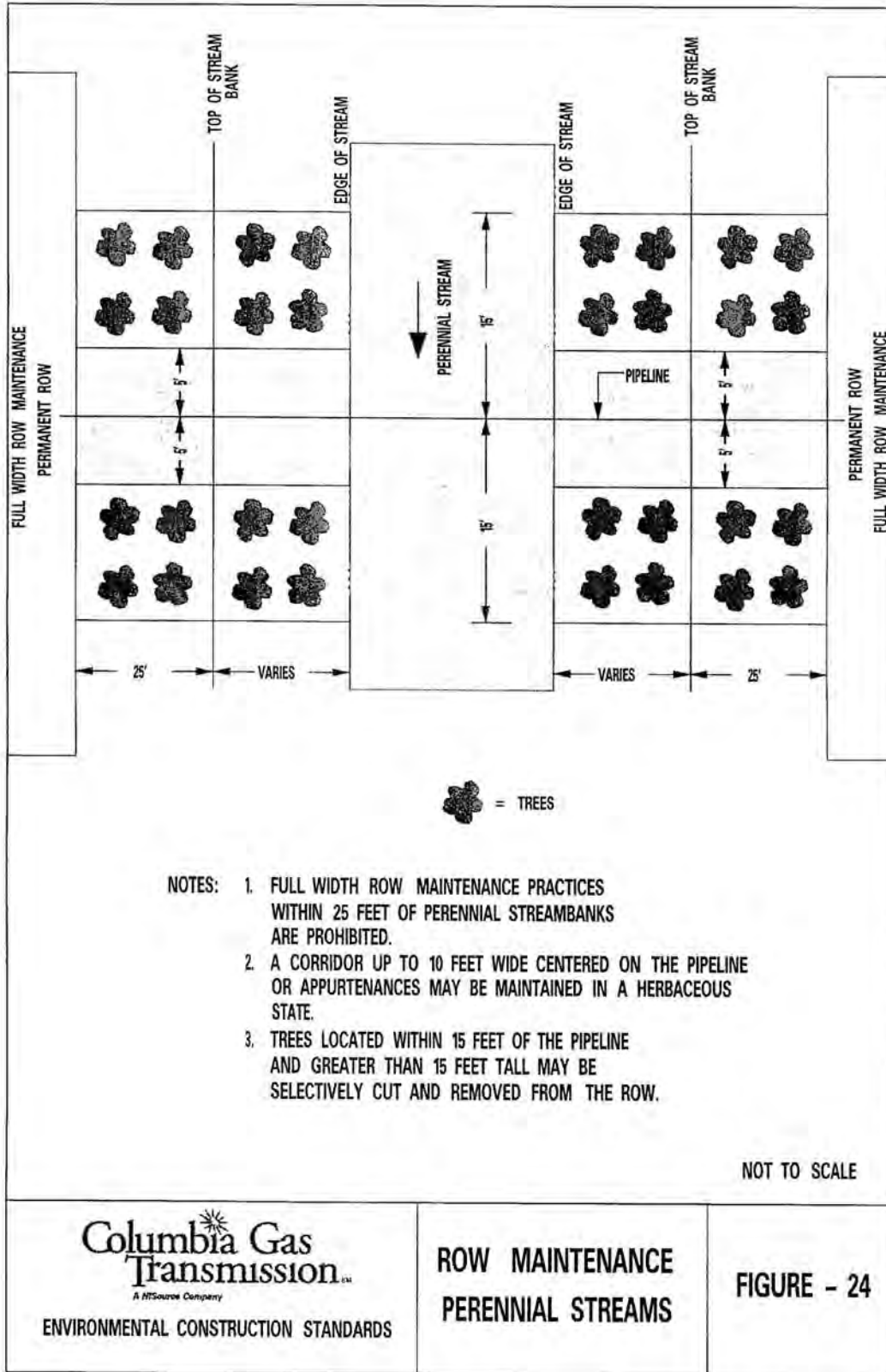



**ENVIRONMENTAL  
CONSTRUCTION STANDARDS**

**VIRGINIA PROJECTS  
2008**

January 2008

---

Columbia Gas Transmission  
Charleston, West Virginia



**Table Of Contents**

- I. Introduction ..... 1
- II. Upland Construction..... 2
  - A. General..... 2
  - B. Right-Of-Way Width..... 2
  - C. Clearing ..... 3
    - 1. Wood Products ..... 3
    - 2. Brush ..... 3
    - 3. Fence Crossings..... 4
  - D. Grading..... 4
    - 1. Tree Stump and Rock Removal and Disposal..... 4
    - 2. Topsoil Conservation ..... 5
    - 3. Erosion Control Devices (Installed During Grading) ..... 5
    - 4. Temporary Road Entrances..... 6
  - E. Access Roads ..... 6
  - F. Residential Areas ..... 7
  - G. Trenching ..... 8
    - 1. Trenching Specifications ..... 8
    - 2. Blasting..... 8
    - 3. Temporary Construction Access Over the Trenchline ..... 9
    - 4. Drainage Tile and Irrigation Facilities ..... 9
  - H. Backfilling Specifications ..... 10
  - I. Final Grading, Restoration And Stabilization..... 10
    - 1. Final Grading ..... 10
    - 2. Soil Compaction Testing..... 11
    - 3. Restoration ..... 11
    - 4. Temporary Stabilization ..... 13
    - 5. Restoring Man-Made Structures..... 13
    - 6. Off-Road Vehicle (ORV) Control..... 13
  - J. Noise Impact Mitigation and Dust Control ..... 14
  - K. Hydrostatic Testing..... 14
- III. Stream and Wetland Crossings ..... 15
  - A. Stream Crossings ..... 15
    - 1. General..... 15
    - 2. Crossing Techniques..... 17
      - a) Minor Waterbodies..... 17
      - b) Intermediate Waterbodies..... 17
      - c) Major Waterbodies..... 17
    - 3. Clearing ..... 18
    - 4. Grading..... 18
    - 5. Trenching..... 18
    - 6. Blasting..... 19
    - 7. Backfilling ..... 19

8.	Restoration .....	19
B.	Wetland Crossings .....	20
1.	General.....	20
2.	Crossing Techniques.....	21
3.	Clearing .....	22
4.	Grading.....	22
5.	Trenching.....	23
6.	Blasting.....	23
7.	Backfilling .....	23
8.	Restoration .....	24
IV.	Spill Prevention, Containment And Control.....	24
A.	General.....	24
B.	Spill Cleanup .....	26
V.	Maintenance.....	26
A.	General.....	26
B.	Upland Areas.....	27
C.	Waterbodies, Wetlands, and Environmentally Sensitive Areas.....	28
VI.	Environmental Construction Management And Inspection .....	28
A.	General.....	28
B.	Environmental Inspector.....	29
C.	Environmental Training .....	30
D.	Contractor’s Environmental Compliance Specialist (Environmental Foreman) ...	31
E.	Environmental Construction Management .....	31
F.	Environmental Variances .....	31
VII.	Emergency Construction.....	32
VIII.	Definition of Terms .....	32
IX.	Tables .....	36
X.	Figures .....	40
A.	Figure 1 – Typical Upland Pipeline Construction Sequence .....	40
B.	Figure 2 – Typical 75ft. Construction Right-of-Way.....	41
C.	Figure 3 – Typical 50ft. Construction Right-of-Way.....	42
D.	Figure 4 – Temporary Construction Gate.....	43
E.	Figure 5 – Typical Topsoil Conservation .....	44
F.	Figure 6A – Interceptor Diversions.....	45
G.	Figure 6B – Interceptor Diversions.....	46
H.	Figure 7 – Sediment Filter Device Silt Fencing .....	47
I.	Figure 8 – Sediment Filter Device Staked Bales.....	48

J.	Figure 9 – Temporary Road Entrance Rock Pads.....	49
K.	Figure 10 – Temporary Road Entrance Terra-Mats .....	50
L.	Figure 11 – Temporary Road Entrance Board Road.....	51
M.	Figure 12 – Typical Erosion Control Measures at Road Crossings.....	52
N.	Figure 13 – Trenchline Barriers and Breakers .....	53
O.	Figure 14A – Sediment Trap .....	54
P.	Figure 14B – Filter Bag .....	55
Q.	Figure 15 – Field Tile Replacement Methods.....	56
R.	Figure 16 – Erosion Control Blanket .....	57
S.	Figure 17 – Typical Stream Crossing Intermittent Stream.....	58
T.	Figure 18 – Typical Stream Crossing Dry-Ditch .....	59
U.	Figure 19 – Typical Stream Crossing Dam and Pump .....	60
V.	Figure 20 – Typical Stream Crossing Wet-Ditch .....	61
W.	Figure 21 – Temporary Equipment Crossing Culvert and Stone.....	62
X.	Figure 22 – Temporary Equipment Crossing Equipment Pads .....	63
Y.	Figure 23 – Typical Wetland Crossing .....	64
Z.	Figure 24 – ROW Maintenance Perennial Streams .....	65

## I. Introduction

Columbia is committed to complying with the applicable environmental rules and regulations of federal, state, and local governments. Columbia's goal is to meet these requirements in the pursuit of a cleaner, safer environment for future operations.

Recognizing this goal, it is Columbia's policy that all construction, operation and maintenance activities be conducted in a safe manner that minimize impacts on stream and wetland ecosystems, wildlife habitat, cultural resources and the human environment. To this end, Columbia has prepared these Environmental Construction Standards (ECS). The ECS provides the minimum requirements to be applied to all construction, operation and maintenance activities.

The general objective of this ECS is to provide Columbia personnel and Columbia's contractors with instructional information, complete with a practical approach to environmental concerns which can arise before, during and after facility construction. More specific objectives include:

- minimize impacts to environmentally sensitive areas;
- use the minimum land required for safe and efficient construction, operation, and maintenance of the facilities;
- prevent erosion and sedimentation during construction; and
- complete construction in a safe and timely manner.

Words and/or phrases which have special meaning (shown in **bold** at first occurrence in text) and acronyms have been defined in Appendix 1.

The intent of the ECS is to confine project-related disturbance to the identified **construction work areas** and to minimize erosion and enhance revegetation in those areas. Any project-related ground disturbance (including erosion) outside of these areas is subject to compliance with all applicable survey<sup>1</sup> (see superscript note on Page 32) and mitigation requirements.

The ECS is focused primarily on pipeline related construction, operation, and maintenance. However, it can be equally applied to all Columbia facilities, for example, storage facilities including well locations, compressor stations, horizontal directional drill locations and measurement/regulation stations. This ECS shall be used as the base document from which Columbia will build individual project-specific Environmental Management and Construction Plans (EM&CP) as called for in Columbia's Policy and Procedure, Plan 120-10. The EM&CP will include written recommendations from the local soil conservation authorities or land management agencies for both temporary and permanent erosion control and revegetation specifications. Federal, State and local agencies having regulations more stringent than this ECS shall supercede<sup>2</sup> (see superscript note on Page 32).

## II. Upland Construction

### A. General

This chapter describes typical upland pipeline construction.

The upland pipeline construction spread operates as a moving assembly line performing specialized procedures in an efficient, planned sequence. Figure 1 presents this typical upland pipeline construction sequence. In addition, special construction crews install and alter fences, bore under roads and railroads (**Slick Bore**), install stream and **wetland** crossings that are not done by conventional upland techniques, **Horizontal Directional Drilling** and construct valve settings and meter/regulator stations.

While construction work is on going, the construction work area will be kept clean of all rubbish and debris resulting from the work. Non-hazardous materials and waste shall be disposed of in an approved landfill. Hazardous waste shall be disposed of in accordance with Columbia policies (Plan 120.03 and 120.04) and federal, state and local regulations.

### B. Right-Of-Way Width

For 14-inch or larger diameter pipelines on new alignments, Columbia typically utilizes a 50-foot wide permanent right-of-way (ROW) and a 25-foot wide temporary construction ROW as illustrated in Figure 2. After the construction work area is restored, the temporary work areas are allowed to revert to its previous uses. The permanent ROW is maintained as Columbia's permanent ROW for the facility. Figure 2 also illustrates the typical pipeline construction work area when paralleling existing facilities.

In addition, there may be instances where extra work areas are needed for topsoil conservation, side hill construction, equipment staging, pipe and material storage, temporary and permanent access, and related construction activities. Such areas will be identified in the project plans and will undergo all required environmental and cultural resources reviews prior to use. In contrast, pipelines may be constructed through confined areas such as extremely steep and narrow ridges. Alternate construction methods may be required in narrow construction work area situations to safeguard workers, equipment, the pipeline, and the environment.

For 12-inch and smaller diameter pipelines, a 50-foot wide ROW is typically used due to a narrower trench and the use of smaller equipment. The typical 50-foot ROW is illustrated in Figure 3. In addition, there may be areas where extra construction work areas are needed as described above.

For non-pipeline construction activities, such as storage well locations and station projects, the construction work area and permanent ROW may vary and can be dependent on property lease, property owner agreements, and/or local topography. For example, the construction work area for a typical storage well is 200 feet by 200 feet and the permanent ROW is a 300 foot radius around the well.

## C. Clearing

The construction work area is cleared to the width specified in the ROW agreements or EM&CP, whichever is less, during clearing operations, all brush and trees will be felled into the construction work area to prevent off-construction work area damage to trees and structures.

The clearing crew and related equipment and equipment necessary for installation of equipment crossings will be permitted a single pass through streams prior to equipment crossing installations unless the stream is a high quality stream or designated as an exceptional value water. Federal, State and local agencies having regulations more stringent than this shall supercede (see superscript note on Page 32).

Should substantial soil disturbance take place during clearing install temporary erosion and sedimentation controls as described in section D-3.

### 1. Wood Products

Wood Products (i.e., sawlogs, pulpwood or cordwood) are the property of the landowner unless otherwise specified. They will not be used for any purpose unless permission is first obtained from the landowner. When the landowner requests salvage of these materials or approves, they will be stockpiled just off the edge of the construction work area, but not within 50 feet of streams, floodplains, or wetlands. Equipment stacking the wood products will not leave the construction work area. Usable timber that measures at least 10 inches in diameter at the butt will be cut into pole lengths or as otherwise negotiated with the landowner. Off-site disposal in other than commercially operated locations is subject to compliance with all applicable survey; landowner approval and mitigation requirements.

### 2. Brush

All cleared brush will be disposed of by one of the following methods:

- Brush may be piled just off the edge of the construction work area but not within 50 feet of streams, floodplains or wetlands. Equipment stacking the brush will not leave the construction work area. Brush piles will be constructed a maximum of 12 feet wide and compacted to approximately 4 feet high, with periodic breaks at a minimum of every 200 feet to permit wildlife travel. The landowner should be consulted to determine acceptable brush pile locations along the construction work area. Landowner approval is required for this method.
- Brush may be burned where permitted by law. The necessary burning permits will be obtained. Fires will be of reasonable size and located and patrolled so that they will not spread off the construction work area.

- The brush may be chipped and given away, buried, or thinly spread (less than 2 inches thick) over the construction work area or blown off the construction work area (per landowner agreement) except in **agricultural lands** or within 50 feet of streams, floodplains, or wetlands. Chipping will be limited to those areas where agreed to with the landowner. During **restoration**, soil will be augmented by the addition of 12 to 15 pounds of nitrogen per ton of chips to aid revegetation.\*
- Brush may be hauled off-site, off-site disposal in other than commercially operated locations is subject to compliance with all applicable survey; landowner approval and mitigation requirements.

\*One ton of chips spread 1 inch thick cover approximately  $\frac{1}{4}$  acre.

### 3. Fence Crossings

Where it is necessary to remove fences, adequate temporary fences or gates as illustrated in Figure 4 will be installed **immediately** or in accordance with landowner agreement. Such temporary fences or gates will be kept closed, except when necessary for construction purposes per landowner agreement. Once construction is completed, permanent fence repairs will be completed. All fences that have been cut or removed will be permanently repaired during restoration to match the original type of the fence as much as possible. Where there is any doubt as to the usability of old fence material, new material will be used in making repairs. Fence repairs will be subject to the approval of the landowner.

## D. Grading

Grading is necessary to provide a smooth and even surface for safe and efficient operation of construction equipment. Grading will be the minimum amount necessary and includes prompt installation of erosion control devices such as interceptor diversions, **sediment filter devices**, and equipment crossings at streams to minimize soil loss and subsequent sedimentation.

### 1. Tree Stump and Rock Removal and Disposal

Tree stumps and large rocks will be cut, graded or removed as necessary to permit construction and to provide adequate clearance for mechanical equipment and other vehicles. Tree stumps that are adjacent to roads will be cut close to the ground or removed.

Stumps and large rocks will be disposed of in the following manner, pending landowner approval:

- buried within the construction work area except in agricultural, residential, or wetland areas;

- windrowed just off the edge of the construction work area with landowners' permission. windrows will be a maximum of 12 feet wide with periodic breaks a minimum of 200 feet apart;
- hauled from the site and disposed of in an approved landfill or other suitable area.

## 2. Topsoil Conservation

Unless the landowner or land management agency specifically approves otherwise, prevent the mixing of topsoil with subsoil by stripping topsoil from either the full work area or from the trench and subsoil storage area (ditch plus soil side method) in:

- actively cultivated or rotated croplands and pastures;
- residential areas;
- hayfields; and
- other areas at the landowner's or land managing agency's request.

In deep soils (more than 12 inches of topsoil), segregate at least 12 inches of topsoil. In soils with less than 12 inches of topsoil make every effort to segregate the entire topsoil layer. Segregated topsoil may not be used for padding the pipe. Figure 5 illustrates topsoil conservation techniques.

The topsoil will be stockpiled separately from all subsoil and will be replaced last during backfilling and **final grading**. Where topsoil is stripped from the entire construction ROW, an additional 25-foot wide temporary work area may be used for topsoil storage with landowners' permission and appropriate environmental approvals. The **Inspector** will determine if additional erosion control devices are needed in topsoil storage areas.

In residential areas, topsoil replacement (i.e., importation of topsoil) is an acceptable alternative to topsoil segregation.

Topsoil stockpiled down slope of the trench shall be stabilized with sediment trapping measures.

## 3. Erosion Control Devices (Installed During Grading)

Temporary erosion controls will be installed before and/or during the initial disturbance of soil. The most effective and versatile erosion control devices are interceptor diversions and sediment filter devices as illustrated and described in Figures 6A, 6B, 7, and 8. Temporary diversions will be maintained during the construction phase until final diversions are installed. Where required grading has significantly



reduced the slope, the Inspector may require fewer temporary diversions consistent with the table on Figure 6.

All temporary erosion control devices, including roadside ditches, will be inspected near the end of each work day or after each storm (rain) event of 1/2 inch or greater, to ensure proper functioning. Any devices damaged beyond functioning will be repaired **promptly**.

All temporary erosion and sediment control measures shall be removed within 30 days after final site stabilization or after the temporary measures are no longer needed, unless otherwise authorized by the local program authority. Trapped sediment and the disturbed soil areas resulting from the disposition of temporary measures shall be permanently stabilized to prevent further erosion and sedimentation.

#### **4. Temporary Road Entrances**

Temporary road entrances as illustrated in Figures 9, 10, and 11 will be installed during grading where the construction work area crosses paved or public roads when needed to maintain safe conditions and to prevent tracking soil and mud onto public roads. These installations are designed to remove mud from vehicle tires and tracks before accessing the road. In addition, paved or public roads will be swept, shoveled or scraped as necessary to keep the road surface safe. Street washing shall be allowed only after sediment is removed by shoveling or sweeping. Typical erosion control measures at road crossings are illustrated in Figure 12. If no access is required onto the roadway the installation of a construction entrance is not required, however, safety fencing should be installed across the ROW and signs designating “no entrance” can be erected to avoid any unintentional entrances.

### **E. Access Roads**

Typically, Columbia requires access roads to the construction and staging areas. New access roads will be built only if existing access is inadequate. The access roads will be a maximum 25 feet wide with additional width in tight turns and at intersections with public roads. The roads will either be temporary (used for access during construction only) or permanent (used during and after construction for operation and maintenance of the facilities). All public roads are available for use as access roads without further environmental review. However, all private access roads intended for use are subject to environmental reviews. Safe and accessible conditions will be maintained at all roadway crossings and access points during construction and restoration.

Access road gradient will be as flat as local topography will practically allow. By breaking or changing grade frequently, fewer erosion problems will be encountered than on long, straight, continuous gradients. Interceptor diversions and/or other erosion and sediment control devices will be installed as needed.

At temporary road entrances, geotextile fabric will be used as illustrated in Figures 9, 10 and 11. The road bed should be cleared of small stubs because

these tend to puncture the fabric, thereby allowing fine particles to mix with the gravel.

Roads will cross streams and wetlands as close as possible to right angles. Road gradients approaching these crossings will be flattened to decrease runoff velocity. Runoff will be dispersed just prior to the crossing by means of an interceptor diversion with a sediment filter device at the outlet. Where conditions permit, new roads will be located at least 25 feet from any stream or wetland except at crossing locations. At crossing locations a temporary equipment crossing shall be installed. Culverts will be sized and placed to permit water flow under the access road. If culverts will be crossed more than twice in 6 month period and if the structure will remain in place for up to 14 days, the culverts shall convey the flow from a 2 year frequency storm event without altering the stream flow characteristics. If the structure will remain in place 14 days to 1 year, the culverts shall be large enough to convey the flow from a 10-year frequency storm event. The hydrologic calculation and subsequent culvert size must be done for the specific watershed characteristics. If the structure must remain in place over 1 year, it must be designed as a permanent measure by a qualified professional.

After construction, temporary access roads (including any additional width used for construction) will be graded and left intact for the landowner's benefit, or removed and the area restored using the same specifications as applied to the construction work area.

## **F. Residential Areas**

The following mitigation measures will be implemented for all residences within 50 feet of the construction work area:

- mature trees and landscaping will not be removed from within the edge of the construction work area unless necessary for safe operation of construction equipment;
- immediately after backfilling the trench, all lawn and landscaping will be restored to final restoration, or temporary restoration pending weather and soil conditions;
- while the trench is open, the edge of the construction work area adjacent to the residence will be safety fenced for a distance of 100 feet on either side of the residence to ensure that equipment, materials and spoil remain within the construction work area;
- a minimum of 25 feet will be maintained between the residence and construction work area for a distance of 100 feet on either side of the residence. If the facility must be within 25 feet of a residence, it must be installed such that the trench does not remain open overnight.

## G. Trenching

### 1. Trenching Specifications

Typically, the trench will not remain open for more than 30 days in any area unless authorized by the Inspector (additional restrictions for stream and wetland areas are provided in Section III). No more than 500 feet of open trench is allowed without a variance from the Natural Resource Permitting group and the Virginia Department of Conservation and Recreation.

- As the trench is completed, trenchline breakers as illustrated in Figure 13 will be installed promptly at every second temporary interceptor diversion at a minimum. Top soil will not be used to construct the breakers. The breakers reduce water velocity and erosion of the trench bottom. The breakers will be maintained promptly. Soft earth plugs (to the top of the trench) should be installed in the trench above public roads on slopes greater than 30 percent where the trench will remain open for more than 7 days. Soft earth plugs shall be installed per the same spacing as temporary trench breakers. When pipe is installed in the trench utilize sand bag breakers.
- Sediment filter devices will be installed around spoil storage areas before digging bore pits, stream crossings, and as necessary wetland crossings.
- If it is necessary to pump water from the trench or bore pits, the water will be pumped into a heavily vegetated upland area where the water will filter back into the ground, a sediment trap as illustrated in Figure 14A, a properly installed sediment filter bag as illustrated in figure 14B, and/or through a sediment filter device such as a series of terra tubes, sediment logs or flocculent logs at least 10 feet from any stream or wetland in order to minimize erosion and subsequent sedimentation of streams or wetlands. Water impounded in the trench will not be released directly or by overland flow into any **waterbody** or wetland. Dewater the trench in a manor that does not cause erosion and does not result in heavily silt laden water flowing into a waterbody or wetland.

When the trench must remain open for a greater length of time, appropriate erosion controls and safety measures will be employed as directed by the Inspector.

### 2. Blasting

All drilling and blasting will be done in a cautious manner, and suitable precautions will be taken to avoid injury or damage to persons, livestock, or other property.

If blasting is necessary within 150 feet of residential or commercial buildings, An independent contractor will be hired to perform pre- and post-blast structural inspections and, if necessary, seismographic monitoring.

In those instances where blasting has the potential to affect water quantity/quality from domestic or agricultural wells or springs in the proximity of the construction work area, Columbia will conduct pre- and post-blasting (within two months of construction work restoration) testing of water wells within an appropriate distance (typically 150 feet) of the pipeline with landowner permission. These tests may include a pump inspection, flow rate, and bacteriological cultures. If a water well is damaged as a result of Columbia's activities, Columbia will provide a temporary source of water and/or compensate the owner.

### **3. Temporary Construction Access Over the Trenchline**

Where access across the trenchline is required, temporary facilities such as trench plugs and fences, wooden mats or steel plates will be constructed or installed to permit safe crossing of livestock, vehicles, equipment, and persons from one side of the trench to the other.

### **4. Drainage Tile and Irrigation Facilities**

Attempt to locate existing drain tiles and irrigation systems. Columbia personnel will contact landowners and/or the local National Resource Conservation Service (NRCS) to determine the locations of future drain tiles that are likely to be installed within 3 years of the authorized construction, if planned, the pipeline will be installed at a sufficient depth to accommodate the drainage tile. For adjacent pipeline loops in agricultural areas, install the new pipeline with at least the same depth of cover as the existing pipeline(s) and within US Department of Transportation (DOT) specifications. Mark locations of drain tiles damaged during construction.

Engage qualified drain tile specialists, as needed to conduct or monitor repairs to drain tile systems affected by construction. Use drain tile specialists from the project area, if available. Drainage tile removed, cut, broke, or otherwise damaged during construction will be repaired or replaced as illustrated in Figure 15. Temporary measures approved by the Inspector will be taken to provide suitable drainage until permanent repairs are made. Repair damaged drain tiles to their original or better condition. Do not use filter-covered drain tiles unless the local soil conservation authorities and landowner agrees.

Water flow will be maintained in crop irrigation systems unless shutoff is coordinated with affected parties.

## H. Backfilling Specifications

Backfilling will follow pipe lowering as closely as practical. Topsoil will not be used to pad the pipe. Soil that has been excavated during construction and not used for backfill will be evenly spread over the cleared construction work area or removed from the site and properly disposed. All waste materials such as trash, stumps, coating and wrap, rubbish, or other refuse will not be placed in the trench.

Trenchline barriers as illustrated in Figure 13 will be placed in the trench prior to backfilling to prevent water movement and subsequent erosion. An engineer or similarly qualified professional shall determine the need for and spacing of trenchline barriers. Otherwise, trenchline barriers shall be installed at the spacing illustrated in Figure 13 and up-slope of any permanent interceptor diversions.

Excess rock, including blast rock, may be used to backfill the trench to the top of the existing bedrock profile. Care should be taken to not damage the pipeline.

## I. Final Grading, Restoration And Stabilization

After construction activities, all disturbed areas will be stabilized with either (1) final grading and restoration; or (2) **temporary stabilization** measures in order to prevent erosion and sedimentation until final grading and restoration can be completed.

### 1. Final Grading

Final grading will be completed within 10 calendar days of backfilling, weather and soil conditions permitting. When conditions require a delay, the 10 day time frame will not start until conditions are suitable for grading. Should unsuitable soil conditions persist, or be expected to persist, for more than 10 calendar days, the Inspector will record the conditions and require the installation of temporary stabilization measures, and final grading and restoration will be delayed. In no case shall final grading be delayed beyond the end of the next recommended seeding season.

If final grade can be established, but conditions are not ideal for permanent seeding, the Inspector will specify application of temporary stabilization measures (including temporary seeding and mulching), and may also consider concurrent application of final seed mix and mulch.

During final grading, soil over the trench may be mounded to allow for future settling. Where fill in the trench or major depressions have settled below ground level, additional fill will be added as needed, and the area brought to final grade. The Inspector may approve a temporary travel lane in the construction work area where needed to facilitate the remainder of construction and/or restoration. This travel lane must be restored when access through the area is no longer required.

Conserved topsoil will be returned during final grading.

Excess rock will be removed from at least the top 12 inches of soil to the extent practicable in all rotated and permanent agricultural land, hayfields, pastures, residential areas, and other areas at the landowner's request. The size, density and distribution of rock on the construction work area should be similar to adjacent areas not disturbed by construction. Diligent efforts will be made to remove rocks greater than 4 inches if, off-construction work areas do not contain rocks greater than 4 inches. The landowner may approve other rock size provisions in writing.

Final erosion control devices will be installed during final grading. Sediment filter devices needed to protect off-construction work area resources will be installed or rebuilt promptly after final grading. Final interceptor diversions will not be installed in agricultural or pasture land without landowner's consent.

## **2. Soil Compaction Testing**

Test topsoil and subsoil for compaction at regular intervals in agricultural and residential areas disturbed by construction activities. Conduct tests on the same soil type under similar moisture conditions in undisturbed areas to identify approximate preconstruction conditions. Use U.S. Army Corps of Engineers-style cone penetrometers or other appropriate devices to conduct tests.

Plow severely compacted agricultural areas with a paraplow or other deep tillage implement. In areas where topsoil has been segregated, plow the subsoil before replacing the segregated topsoil. Alternatively, make arrangements with the landowner to plant and plow under a "green manure" crop, such as alfalfa, to decrease soil bulk density and improve soil structure. If subsequent construction and cleanup activities result in further compaction, conduct additional tilling.

Perform appropriate soil compaction mitigation in severely compacted residential areas.

## **3. Restoration**

Restoration as defined in Appendix 1, will begin within 6 days of final grading, weather and soil conditions permitting. Fertilizer and lime will be disked into the soil (except rocky soils) to a depth of 3 to 4 inches to prepare a seedbed. In rocky soils, fertilizer and lime may be incorporated into the soil with tracked equipment. Seeding and mulching the construction work area will promptly follow seedbed preparation. Mulch will be anchored promptly after installation. Mulch tacifiers used in accordance with the manufacturers recommendations may be used as an alternative.

Columbia will follow the Virginia DCR for Seeding and Soil Additive Requirements. (Refer to Erosion & Sediment Control Technical Bulletin No. 4 found at

[http://www.dcr.virginia.gov/soil\\_&\\_water/documents/esnutan.pdf](http://www.dcr.virginia.gov/soil_&_water/documents/esnutan.pdf)) If Tall Fescue is used, plant endophyte free certified seed.

If hydroseeding is utilized, lime and fertilizer applications should be equivalent to conventional method applications unless ROW agreement, permit or the local NRCS provides project specific recommendations. Hay or straw mulch shall be applied at 2 tons per acre over hydroseeding. Hydromulch can be used in conjunction with (for texture purposes) but not substituted for hay or straw mulch. **Scarify** the seedbed to facilitate lodging and germination of seed.

Uniformly apply and cover seed in accordance with the written recommendations of the local soil conservation authorities or land management agencies.

Base seeding rates on Pure Live Seed. Use seed within 12 months of seed testing. Treat legume seed with an inoculate specific to the species. For conventional seeding, use 4 times the manufactures recommended rate of inoculate. For hydroseeding, use 10 times the recommended rate of inoculate.

In the absence of recommendations from the local conservation authority, a seed drill equipped with a cultipacker is preferred for application, but broadcast or hydroseeding can be used at double the recommended seeding rates. Where seed is broadcast, firm the seedbed with a cultipacker, roller or other suitable means after seeding.

Restoration will not be performed in agricultural lands from the beginning of the spring thaw through May 15 unless requested by the landowner. Restoration will be coordinated with the landowner's planting schedule. Active pasturelands will not be mulched. Grazing deferment plans will be developed with willing landowners, grazing permittees, and land management agencies as appropriate to minimize grazing disturbance of revegetation efforts.

Permanent seeding, liming, and fertilizing may be performed by the landowner. The Inspector will ensure that the restoration is satisfactory and consistent with the regulatory requirements.

A permanent vegetative cover shall be established on denuded areas not otherwise permanently stabilized. Permanent vegetation shall not be considered established until a ground cover is achieved that, is uniform, mature enough to survive and will inhibit erosion.

Restore all turf, ornamental shrubs, and specialized landscaping in accordance with the landowner's request, or compensate the landowner. Restoration work must be performed by personnel familiar with local horticultural and turf establishment practices.

Jute netting as illustrated in Figure 16 or equivalent approved by the Inspector may be used on **steep slopes** to help stabilize the construction work area.

#### **4. Temporary Stabilization**

When the Inspector determines that temporary stabilization measures are required, they will be completed as soon as possible. The seeding and mulching rates are provided in Table 2a. Consideration will be given to the following when determining if temporary stabilization measures are to be implemented:

- If unsuitable soil conditions persist, or be expected to persist, for more than 10 calendar days during final grading; and
- anticipated weather conditions; and
- resources on and off the construction work area to be protected.

If temporary stabilization measures are utilized, final grading and/or restoration must commence once weather and soil conditions permit.

Apply mulch in accordance with the specifications outlined in this section except during temporary restoration; increase mulch application on all slopes (8 percent or more) within 100 feet of waterbodies and wetlands to a rate of 6,000 lbs/acre (3 tons).

#### **5. Restoring Man-Made Structures**

All existing man-made installations that are disturbed or damaged during construction along new ROW will be repaired or replaced and left in equivalent or better condition than they were found prior to construction, unless alternative arrangements with landowners dictate otherwise.

Man-made installations on existing ROW that are disturbed or damaged during construction will be addressed consistent with Columbia's encroachment policy.

#### **6. Off-Road Vehicle (ORV) Control**

Columbia will discuss with each landowner and park manager along new ROW (not adjacent to existing ROW) in forest lands the need for ORV control. If requested, one or more of the following ORV control measures will be installed:

- Plant conifers (pine trees) across the construction work area. The spacing of trees and length of construction work area planted should provide for adequate facility maintenance, but should be sufficient to limit access and to screen the ROW from view. Trees will not be planted directly over the pipeline.



- Install a slash and timber barrier, a pipe barrier, or a line of boulders across the construction work area to restrict vehicle access.
- Install a locking gate with fencing extending a reasonable distance to prevent bypass.
- Install “No Trespass” signs.

## J. Noise Impact Mitigation and Dust Control

Construction equipment will be properly muffled and maintained to avoid producing excessive noise near **noise sensitive areas**.

Efforts will be made to control dust at sensitive areas such as residential areas and road crossings. Water trucks will be used at a minimum to dampen the work area if dust becomes a problem.

## K. Hydrostatic Testing

Typically, Columbia verifies a facility’s integrity by hydrostatic testing. Water will be drawn from local sources (streams, ponds, public water supplies) in a manner that will minimize impacts to the environment and other existing users, while maintaining adequate stream flow. Water from state designed *high quality streams* or *exceptional value waters*, waterbodies which provide habitat for federally listed threatened or endangered species, or streams utilized as public water supplies will not be used unless other water sources are not readily available and the appropriate federal, state or local agency permits its use.

Intake hoses will be screened.

Locate hydrostatic test manifolds outside wetlands and riparian areas to the maximum extent practicable.

All required federal, state and local approvals for the withdrawal and/or discharge of hydrostatic test water will be obtained prior to such activities.

Jurisdictional agencies will be notified of the intent to withdraw water from streams. Notify appropriate state agencies of intent to use specific sources at least 48 hours before testing activities unless they waive this requirement in writing.

Maintain adequate flow rates to protect aquatic life and provide water for downstream withdrawals by existing users.

Comply with all approval/permit conditions which may include notifying the appropriate state agency of withdraw/discharge and collection of samples in accordance with permit conditions where required.

All welds will be radiographically inspected or hydrostatically tested before pipe installation under waterbodies or wetlands.

The discharge of the hydrostatic test water will be performed in a manner that minimizes erosion and sedimentation to waterbodies. The energy of the released test water will be dissipated by discharging the water:

- into a well-vegetated upland area;
- into a tank(s)
- into a body of water (with all required permits); or
- through sediment filter devices and/or a sediment trap to filter out and/or settle out various particulate matter and allow it to infiltrate through the soil.

If necessary, regulate the water discharge rate, use energy dissipation device(s); and/or install sediment barriers to prevent erosion, streambed scour, suspension of sediments, or excessive streamflow. During the discharge, the Inspector must ensure that erosion and sedimentation are properly controlled.

Do not discharge into waters from state designated exceptional value waters, waterbodies which provide habitat for federally listed threatened or endangered species, or streams utilized as public water supplies unless the appropriate federal, state or local agency grants permission.

If Methanol is used during the test or injected after discharging the water, to dry the pipe approval must be granted from the Natural Resource Permitting Department pending agency approvals. Excess methanol may be retrieved from the facility and used during subsequent operation of Columbia's facilities. Methanol can not be discharged to the environment.

This guidance is for hydrostatic testing of new pipe. Permitting requirements associated with hydrostatic testing of used pipe can be extensive. Contact the Construction Permitting Specialist prior to testing any used pipe.

### **III. Stream and Wetland Crossings**

#### **A. Stream Crossings**

##### **1. General**

The main objective of any waterbody crossing is to construct the pipeline in a manner which minimizes erosion and subsequent sedimentation into the waterbody. Crossings will be constructed as close as possible to right angles with the waterbody channel. Adequate downstream flow rates will be maintained at all times to protect aquatic life and prevent the interruption of existing downstream uses. Each waterbody crossing will

be treated as a separate construction entity, such that trenching, pipe installation, backfilling and temporary stabilization or final restoration are completed in the minimum number of consecutive calendar days possible. Whenever a time limit is imposed (See Section III.A.2) on a crossing procedure, that time limit is only applicable to trenching (except blasting), pipe installation, and backfilling. (See time limits for restoration Section III.A.8). The bed and banks of a watercourse shall be stabilized immediately after work in the watercourse is completed (including riprap placement). Clearing, grading and equipment crossing installation and removal activities are not included as part of the separate construction entity. Construction equipment will not be allowed in the water except as provided in this Section.

Unless expressly permitted or further restricted by the appropriate state agency in writing on a site-specific basis, crossings must be constructed during the following time windows:

- Coldwater Fisheries - June 1 through September 30
- Coolwater and Warmwater Fisheries - June 1 through November 30

When work in a live watercourse is preformed, precautions shall be taken to minimize encroachment, control sediment transport and stabilize the work area to the greatest extent possible during construction. Non-erodible material shall be used for the construction of dams. Earthen fill may be used for dams (dam and pump method) if placed in non-erodible containers.

Columbia will notify authorities responsible for potable water supplies at least one week, or as required by state or local regulation, prior to any waterbody crossing.

When water levels are temporarily high, the Inspector will direct that starting any waterbody crossing be postponed until water levels subside.

Any extra work areas will be located at least 50 feet away from the water's edge, except where the adjacent upland consists of actively cultivated or rotated cropland or other disturbed land. Where topographic conditions do not permit a fifty-foot setback, contact the Natural Resources Permitting Group for approval. All extra work areas must be located at least 10 feet from the water's edge and limited to the size needed to construct the crossing. Pipe assembly for the waterbody crossing is usually performed in the extra work areas prior to or concurrently with trenching.

Standards relating to spill prevention at waterbodies are contained in Section IV., "Spill Prevention".

If the facility parallels a waterbody, attempt to maintain at least 15 feet of undisturbed vegetation between the waterbody and the right-of-way except at the crossing location. Where waterbodies are adjacent to the

construction right-of-way, install sediment barriers along the edge of the construction right-of-way as necessary to contain spoil and sediment within the right-of-way.

Waterbody buffers (extra work area setbacks, refueling restrictions, etc.) must be clearly marked in the field with signs and/or highly visible flagging until construction related ground disturbing activities are completed.

## 2. Crossing Techniques

Columbia typically utilizes either the dry-ditch (flume pipe) or dam and pump method to install pipelines across waterbodies. Figures 18 and 19 illustrate these methods. **Upland construction** techniques may be used for **intermittent waterbody** crossings without perceptible flow at the time of the crossing, provided that a culvert is **promptly** installed after trench to carry stormwater flow across the trench area and the erosion and sediment control devices illustrated in Figure 17 are installed. Should the intermittent stream start to flow it will be completed within 72 hours.

### a) Minor Waterbodies

For crossings of coldwater fisheries and coolwater and warmwater fisheries considered significant by the state, install the pipeline using the dry-ditch method.

For other **minor waterbody** crossings, complete construction in the waterbody using the dam and pump method (figure 19) within 72 hours. The wet ditch (Figure 20) method will not be used unless a variance from the Virginia Department of Conservation and Recreation has been granted and approval from the Natural Resource Permitting group has been received.

### b) Intermediate Waterbodies

The dam and pump method will be used for all **intermediate waterbody** crossings. Columbia will attempt to complete trenching and backfill work in the waterbody within 72 hours, unless site-specific conditions make completion within 72 hours infeasible. (See Section III.A.1 for further time limit restrictions).

### c) Major Waterbodies

Due to their sensitive nature, **major waterbody** crossings will have site-specific construction plans approved by the Natural Resource Permitting group. Directional drilling may be considered as an alternative for these crossings.

### **3. Clearing**

Tree and brush clearing will be performed as previously described in Section II, "Upland Construction". All cleared materials will be disposed of at least 50 feet from the water's edge.

### **4. Grading**

Grading equipment will not enter the water to grade the banks. Waterbody banks will be graded only where, and as much as, necessary to permit safe and efficient operation of construction equipment. During grading operations, sediment filter devices will be installed promptly as close to the water as practical. All disturbed areas within 50 feet of the water's edge will be promptly mulched. The mulch will be maintained until the waterbody crossing restoration is complete. Spoil from grading will be piled at least 10 feet from the stream banks and immediately protected with sediment filter devices so that it will not erode into the waterbody. On waterbody crossings with approaches sloped 5 percent or greater, interceptor diversions will be installed 50 feet from the water's edge to divert surface runoff into adjacent vegetation. If vegetation is sparse or nonexistent, a sediment filter device will be installed at the discharge of the diversion.

Construction equipment bridges consisting of culvert(s) with clean rock backfill or equipment pads as illustrated in Figures 21 and 22 will be installed prior to or during grading operations at all waterbodies. (Refer to Section II.E for culvert sizing requirements). Equipment bridges are not required at minor waterbodies that do not have a state-designed fishery classification (for example, agricultural or intermittent drainage ditches). However, if an equipment bridge is used, it must be constructed in accordance with this ECS. (See Section II.E for installation requirements).

### **5. Trenching**

Notifications to jurisdictional agencies will be made at least 2 days prior to any trenching in waterbodies.

Prior to trenching within the waterbody, water impounded in the upland trench will be pumped into a sediment trap and/or properly installed filter bag and/or a series of terra tubes, sediment logs or flocculent logs. (Figures 14A and 14B)

Sediment filter devices for trench spoil will be installed prior to commencing trenching activities. Sediment filter devices can be temporarily removed from the trench line to allow trenching activities to proceed.

All spoil from minor and intermediate waterbody crossings, and upland spoil from major waterbody crossings, must be placed in the construction ROW at least 10 feet from the water's edge or in additional extra work areas.

For all new construction activities, the minimum depth of cover for all waterbody crossings is 48 inches in normal soils and 24 inches in consolidated rock.

Trench plugs will be used at all non-flumed waterbody crossings to prevent diversion of water into upland portions of the pipeline trench and to keep any accumulated trench water out of the waterbody. Trench plugs must be of sufficient size to withstand upslope water pressure.

## **6. Blasting**

During the pre-planning of waterbody crossings, an evaluation will be made concerning the need for blasting. If the evaluation is inconclusive, the waterbody bed will be tested for consolidated rock prior to trenching.

Blasting will not be done within waterbody channels without prior approval from government authorities having jurisdiction and at least 2 day notice to the authority.

If the waterbody bottom is consolidated rock, it can be drilled and shot at any time prior to commencing the crossing. However, removal of shot rock, and any additional drilling, shooting and material removal, must be completed within the minimum number of consecutive calendar days practical. The time frame for completing the crossing will immediately commence once a trench of appropriate dimensions is established.

## **7. Backfilling**

If dewatering the trench is required before backfilling, pump the water into a sediment trap, and/or a properly installed filter bag, (Figures 14A and 14B) and a series of terra tubes, sediment logs or flocculent logs. Dewater the trench in a manor that does not cause erosion and does not result in heavily silt laden water to enter the waterbody.

Waterbody bottoms will be returned as near as practical to their original contours. Spoil from the trench will be used as backfill. Clean gravel or native cobbles will be used for the final one foot of fill in the backfilled trench in all coldwater fisheries.

The sediment filter devices at the water line will be promptly reinstalled after backfilling.

## **8. Restoration**

The preferred restoration method is to immediately start, and to achieve final grade and restore the waterbody, its banks, and 50 foot buffers within 24 hours of backfilling. In the absence of site-specific seeding recommendations, the specifications listed in Table 2a will be used. If conditions do not permit the preferred method, the construction work area not in use for access will be promptly rough graded and stabilized in accordance with Table 2b.

For dry-ditch crossings, complete bank stabilization before returning flow to the waterbody channel.

Liquid mulch binders will not be used within 100 feet of waterbodies.

For each waterbody crossed, install a permanent interceptor diversion and a trench breaker at the base of slopes near the waterbody. Locate the trench breaker immediately upslope of the slope breaker.

All equipment bridges will be removed once access in the area is no longer required.

Replacement of waterbody banks will be at the approximate original contour. If the waterbody banks are such that an unstable final soil grade would result and vegetative stabilization is inadequate, the Inspector will require mechanical stabilization of the waterbody banks. Mechanical stabilization includes riprap, gabions, jute netting, etc.

Unless otherwise specified by state permit, limit the use of riprap to areas where flow conditions preclude effective vegetative stabilization techniques, such as seeded erosion control fabric.

Revegetate disturbed riparian areas with native pre-construction vegetation. Refer to the Virginia Erosion and Sediment Control Handbook (current edition) for vegetative stream bank stabilization (STD and SPEC 3.22).

If riprap or gabion baskets are used refer to the Virginia Erosion and Sediment Control Handbook (current edition) for structural stream bank stabilization (STD and SPEC 3.23) and riprap (STD and SPEC 3.19).

Install erosion control fabric, figure 16, such as jute thatching or bonded fiber blankets at a minimum, on waterbody banks at the time of final bank re-contouring. Anchor the erosion control fabric with staples or other appropriate devices.

Sediment filter devices will be removed once permanent revegetation is successful.

## **B. Wetland Crossings**

### **1. General**

The main objective of any wetland crossing is to construct the pipeline and restore the original contour of the wetland. Wetlands will be marked in the field by a knowledgeable person prior to the start of construction. The Inspector will maintain these field markings during construction. A maximum 75-foot wide construction work area may be used through wetlands.

Mulch will not be used as a temporary erosion control measure in wetlands.

Aboveground facilities will not be located in any wetland, except where the location of such facilities outside of wetlands would prohibit compliance with US DOT regulations.

When water levels are temporarily high, the Inspector will direct that starting construction in the wetland will be postponed until after the water levels subside.

Standards relating to spill prevention at wetlands are contained in Section IV, "Spill Prevention".

## 2. Crossing Techniques

For wetland crossings without standing water or saturated soils, upland construction techniques can be used provided the top 12 inches of soil taken from the trench is stockpiled separately from the remaining excavated material. The construction right-of-way may be used for access when the wetland soil is firm enough to avoid rutting or the construction right-of-way has been appropriately stabilized to avoid rutting (e.g., with timber riprap, prefabricated equipment mats, or terra mats). In wetlands that cannot be appropriately stabilized, all construction equipment other than that needed to install the wetland crossing shall use access roads located in upland areas. Where access roads in upland areas do not provide reasonable access, limit all other construction equipment to one pass through the wetland using the construction right-of-way.

Wetland crossings in non-saturated soil wetlands will be constructed in a manner that will minimize the amount of time construction activities are occurring in the wetland, such as the length of time the topsoil is segregated and the trench is open.

Wetland crossings with standing water or saturated soils will be constructed as separate construction entities, such that trenching, pipe installation, backfilling, and restoration are completed in the minimum number of consecutive calendar days necessary. Clearing, grading and equipment crossing installations are not included as part of the separate construction entity. The "push-pull" or "float" technique of pipe installation will be utilized whenever water and other site conditions permit. Assemble the pipeline in an upland area unless the wetland is dry enough to adequately support skids and pipe.

If standing water or saturated soils are present or if construction equipment causes ruts or mixing of the topsoil and subsoil, use **low-ground-weight** construction equipment, or operate normal equipment on timber riprap (only 2 layers), prefabricated equipment mats or terra mats. Tree stumps, rock, gravel, soil imported from outside the wetland or brush will not be used to stabilize the construction work area or as equipment



pads in wetlands. Remove all equipment mats, and timber riprap during restoration of the wetland.

Staging areas will be located at least 50 feet from the wetland edge except where the adjacent upland consists of actively cultivated or rotated cropland or other disturbed land and will be limited to the minimum necessary to construct the crossing. If topographic conditions do not permit a 50-foot setback, these areas must be located at least 10 feet from the wetland's edge with prior approval from the Natural Resources Permitting group.

The only access roads, other than the construction work area, that can be used in wetlands without FERC approval are those existing roads that can be used with no modification and no impact on the wetland.

Limit construction equipment operating in wetland areas to that needed to clear the construction work area, dig the trench, fabricate and install the pipeline, backfill the trench, and restore the ROW. All other construction equipment shall use access roads located in upland areas to the maximum extent practicable. Where access roads in upland areas do not provide reasonable access, limit all other construction equipment to one pass through the wetland using the construction work area.

A typical wetland crossing is illustrated in Figure 23.

### **3. Clearing**

Tree and brush clearing will be performed as previously described in Section II, "Upland Construction". Cut vegetation off at ground level, leaving existing root systems in place, and remove (vegetation) from the wetland for disposal.

### **4. Grading**

Grading in wetlands will consist of the minimum necessary for safe and efficient equipment operation. Limit pulling of tree stumps and grading activities to directly over the trenchline. Do not grade or remove stumps or root systems from the rest of the construction work area in wetlands unless the Chief Inspector and **Environmental Inspector** determine that safety-related construction constraints require removal of tree stumps from under the working side of the construction work area. Areas where stumps are removed will be noted by the Inspector so, if necessary, those areas can be replanted with woody vegetation as described in wetland restoration.

Where wetlands are adjacent to the construction work area, install sediment barriers along the edge of the construction work area as necessary to prevent sediment flow into the wetland. Remove these sediment barriers after successful construction work area restoration has occurred.

Sediment filter devices will be installed promptly across the construction work area during grading at any wetland edge and maintained until construction work area revegetation is complete. Temporary interceptor diversions will be installed adjacent to wetlands. Locations for these devices are illustrated in Figure 23.

## **5. Trenching**

Sediment filter devices can be temporarily removed from the trenchline to allow trenching activities to proceed. Spoil piles will be protected with sediment filter devices, if determined necessary by the Inspector, to prevent the flow of spoil off the construction work area.

## **6. Blasting**

During the pre-planning of crossing wetlands with standing water or saturated soils, an evaluation will be made concerning the need for blasting. If the evaluation is inconclusive, the wetland will be tested for consolidated rock prior to trenching. If the wetland has consolidated rock, it must be drilled and shot as part of the single construction entity.

## **7. Backfilling**

If trench dewatering is required, the water will be filtered and discharged through a sediment trap and/or a filter bag and/or a series of terra tubes, sediment logs or flocculent logs so that no heavily silt-laden water enters directly into the wetland. Spoil from the trench will be used as backfill. The surface will be recontoured as closely as practical to the original so that drainage patterns will not be changed. In wetlands without standing water or saturated soils, the conserved top soil layer will be returned to the surface during backfilling.

Sediment filter devices will be promptly installed after backfilling.

Where the pipeline trench may drain a wetland, construct trenchline barriers and/or seal the trench bottom as necessary to maintain the original wetland hydrology. For each wetland crossed, install a permanent interceptor diversion and trenchline barriers at the base of slopes near the boundary between the wetland and adjacent upland areas. Locate the trenchline barriers immediately upslope of the interceptor diversion.

Concrete coating activities will not take place within 100 feet of any wetland.

## **8. Restoration**

Upon completion of construction in wetland areas with standing water or saturated soils, all access improvements will be promptly removed. In the absence of specific recommendations from conservation authorities, the seed mix and rate specified in Table 2b will be used. Fertilizer, lime or mulch will not be used, unless required in writing by a jurisdictional agency.

Asphaltic emulsions will not be used to stabilize mulch within 100 feet of wetlands. Liquid mulch binders will not be used within 100 feet of wetlands.

## **IV. Spill Prevention, Containment And Control**

### **A. General**

Spills of any amount of petroleum products or polluting materials are to be prevented. The following will be followed to help avoid spills and minimize the impact of spills which accidentally occur:

- Bulk quantities up to 5,000 gallons of diesel fuel and 5,000 gallons of gasoline will be stored in one location (the fuel depot) for the Project. Adequate spill containment measures, such as containment dikes, combined with impervious lining will be installed before fuel storage tanks are filled, and will be maintained throughout the Project. Bulk quantities of hazardous liquids (e.g., solvents and lubricants) will be stored at the fuel depot locations.
- Generally, fuel will be stored at the equipment staging areas and as much equipment as practical will be refueled there. Any equipment that must be refueled in the field will be fueled from tanks carried to the work site. Fuel carriers (greater than 110 gallons capacity) will not be permitted to cross wetlands or ford waterbodies. Equipment refueling will not be performed within 100 feet of any body of water or wetland, except by hand-carried cans (5 gallon maximum capacity), when necessary. If construction equipment must be refueled within 100 feet of a waterbody, follow the procedures outlined in the project-specific SPCC Plan. Care will be taken during refueling not to overfill or spill fuel onto the housing of equipment.
- Lesser quantities of fuel (up to 500 gallons) and solvents and lubricants (e.g., motor oils, hydraulic fluid) may be stored along the construction work area as necessary to service equipment used on the Project (quantities vary depending on the size of the construction spread being used), provided that this storage does not conflict with other parts of this plan. Sorbent booms and clean-up kits will be kept at all storage locations and will be readily available at all times.

- All fuel storage areas will be located at least 100 feet from streams, ponds, or wetlands; at least 200 feet from active private water wells, and at least 400 feet from municipal water wells, unless using an operational fuel storage area established on Columbia property. All fuel storage areas will not be located within any designated municipal watershed area (except at locations designated for these purposes by an appropriate governmental authority): Equipment servicing, lubricating and refueling will also be in accordance with these requirements whenever possible (i.e., except when stationary equipment such as drilling rigs is being used). Where these conditions can not be met, the Environmental Inspector will prepare a supplemental SPCC plan, based on field conditions, to protect these resources.
- Use of hazardous materials for vehicle maintenance will follow the same requirements mentioned above for equipment refueling. Impervious or sorbent materials will be placed under the work area before the work begins. Additional sorbent materials will also be readily available. Waste materials created during maintenance (e.g., used oil) will be collected for proper disposal. The work site and the vehicle will be checked by a Columbia inspector after the maintenance work is complete to ensure that all hazardous materials are properly contained. All waste material, including partially used or empty containers, discarded parts, clean up rags, and used sorbent materials, as well as discarded hazardous materials containers (e.g., oil cans, grease tubes), will be collected for proper disposal.
- All motor fuel, lube oil, chemicals, and other polluting substances will be tightly sealed and clearly labeled during transportation and storage.
- Fuel trucks, pumps, mechanics' vehicles, the contractor's foremen's vehicles and Columbia Inspectors' vehicles will be equipped with spill kits containing absorbent materials approved for petroleum products and have sufficient tools and material to stop leaks.
- Construction equipment will not be washed in any body of water or wetland, nor will runoff resulting from washing operations be permitted to directly enter any body of water or wetland area.
- Construction equipment, vehicles, materials, hazardous materials, chemicals, fuels, lubricating oils, and petroleum products will not be parked, stored, or serviced within 100 feet of all bodies of water and wetlands.
- All equipment will be checked, by a Columbia inspector, daily for leaks prior to beginning work in bodies of water or wetlands. Steps will be taken to repair leaks or remove the equipment from service, if necessary.

If barge mounted equipment is to be employed, the contractor will develop specific spill-prevention plans to be reviewed and approved by Natural Resource Permitting group.

## **B. Spill Cleanup**

Spills occurring during construction, operation and maintenance are to be reported immediately to the Monitoring Center at 1-800-835-7191 in accordance with Columbia policies, plans and procedures (Plan Number 120.02.01). Columbia's Environmental Health and Safety department will be responsible for contacting the appropriate agencies, except as provided for below.

If the call to the Monitoring Center is not returned within 30 minutes and the spill has impacted water, the person discovering the spill or release will contact the National Response Center at 1-800-424-8802 and report the release. That person will continue calling the Monitoring Center until a representative is reached.

If a spill should occur, Columbia will ensure immediate action is taken to minimize the impact of the spill, and see that appropriate cleanup action is immediately undertaken.

In the event of a spill into or in the vicinity of bodies of water or wetlands, the following will occur immediately:

- the source will be immediately stopped;
- the spill will be contained by placing sorbing booms or constructing dikes;
- the spill will be collected with sorbing materials, skimmed off water surfaces with booms, and/or the contaminated soil will be excavated;
- the waste materials will be properly stored and disposed in accordance with Columbia policy.

The affected areas will be restored as closely as possible to their previous condition.

If the spill is such that Columbia personnel or the on-site contractor can not immediately and effectively respond, Columbia's environmental contractor, who specializes in spill cleanup, will be employed.

## **V. Maintenance**

### **A. General**

Maintenance of Columbia's ROWs is an ongoing process which is governed by Columbia policy, certificate and permit conditions and landowner agreements. On FERC certificated pipelines full width vegetation maintenance clearing shall not be done more frequently than every 3 years. However, to facilitate periodic corrosion and leak surveys, a corridor not exceeding 10 feet in width centered on the pipeline may be maintained annually in a herbaceous state. In no case shall

full width vegetation maintenance clearing occur between April 15 and August 1 of any year on FERC certificated pipelines.

Maintenance activities will be performed with emphasis on preservation and enhancement of the environment. All applicable certificate and permit conditions will be incorporated into the future maintenance plan of the facility.

Specific procedures when required by regulations will be developed in coordination with the appropriate agency to prevent the introduction or spread of noxious weeds and soil pests resulting from construction and restoration activities.

## **B. Upland Areas**

Plant growth on the ROW will be inspected regularly and maintained for the life of the facility. Follow-up inspections will occur after the first and second growing season.

Revegetation in non-agricultural areas shall be considered successful if upon visual survey the density and cover of non-nuisance vegetation are similar in density and cover to adjacent undisturbed lands. In agricultural areas, revegetation shall be considered successful if crop yields are similar to adjacent undisturbed portions of the same field.

Continue revegetation efforts until revegetation is successful.

Monitor and correct problems with drainage and irrigation systems resulting from pipeline construction in active agricultural areas until restoration is successful.

ROW are generally maintained by mowing or other mechanical means, and through the use of herbicides. Use of herbicides will follow Columbia policy. Only those herbicides approved by the EPA will be used. Herbicide use will be in accordance with existing regulations and label instructions.

If revegetation is not successful, the area will be restored as soon as practical.

Problems with drainage and irrigation systems resulting from construction activities will be reported to the local Operations Team Leader. Corrective measures will be performed as needed.

Erosion problems on the facility ROW and access roads will be reported to the local Operations Team Leader or the Natural Resource Permitting group. Corrective measures will be performed as needed. Erosion control devices that are no longer required must be removed. Removal of the erosion control devices will be at the discretion of the local Operations Team Leader and the Engineering & Construction department. Similarly, additional erosion control devices will be installed as required.

Maintain all temporary sediment barriers in place until permanent revegetation measures are successful or the upland areas adjacent to wetlands, waterbodies,

or roads are stabilized. Remove temporary sediment barriers from an area once that area is successfully restored.

### **C. Waterbodies, Wetlands, and Environmentally Sensitive Areas.**

Columbia will work cooperatively with appropriate government agencies in an effort to minimize the impacts of ROW maintenance in waterbodies, wetlands, and other environmentally sensitive areas.

Limit vegetation maintenance adjacent to waterbodies to allow a riparian strip at least 25 feet wide, as measured from the waterbody's mean high water mark, to grow. Figure 24 illustrates ROW maintenance standards near waterbodies.

Do not use herbicides or pesticides in or within 100 feet of a waterbody or wetland except as specified by the appropriate land management or state agency.

In wetlands, a corridor up to 10 feet wide centered on the pipeline will be maintained in a herbaceous state. In addition, trees that are located within 15 feet of the pipeline and greater than 15 feet tall may be selectively cut. All felled trees will be removed from the wetland.

Attempts will be made to prevent the invasion or spread of undesirable exotic vegetation (i.e., purple loosestrife and phragmites) within wetland areas disturbed during construction. Typically, these efforts include Columbia's wetland construction techniques and the use of approved herbicides.

Monitor the success of wetland revegetation annually for the first 3 years after construction or until wetland revegetation is successful. Revegetation should be considered successful if the cover of native herbaceous and/or woody species is at least 80 percent of the total area, and the diversity of native species is at least 50 percent of the diversity originally found in the wetland. If revegetation is not successful at the end of 3 years, develop and implement (in consultation with a professional wetland ecologist) a remedial revegetation plan to actively revegetate the wetland with native wetland herbaceous and woody plant species. Continue revegetation efforts until wetland revegetation is successful.

For certain locations through Columbia's system listed threatened, endangered, or special concern species and their habitats have been identified. In addition, eligible cultural resources, wetlands, and other environmentally sensitive areas may also have been identified. In these instances, permits normally include maintenance provisions that must be adhered to for the life of the facility.

## **VI. Environmental Construction Management And Inspection**

### **A. General**

Columbia is responsible for compliance with the environmental conditions contained in a Projects' EM&CP, which include all permits and other approvals. One or more Environmental Inspectors will be assigned to every Project and will report to the Columbia employee in responsible charge. At least one

Environmental Inspector is required for each construction spread during active construction or restoration. Environmental Inspectors shall have peer status with all other activity inspectors.

## **B. Environmental Inspector**

The Environmental Inspector is responsible for assuring that the construction activity is performed in accordance with the environmental conditions of the EM&CP and landowner requirements and have the authority to stop work and order appropriate corrective action as outlined in Section VI.E. For construction activities that are found by the Natural Resource Permitting group to have minimal environmental impacts, the Environmental Inspector may also serve to monitor other construction functions.

At a minimum, the Environmental Inspector/Responsible Land Disturber/Certified Inspector shall be responsible for:

- ensuring compliance with the requirements of the EM&CP, ECS, and any permits, landowner agreements or FERC certificates obtained for the Project;
- Identifying, documenting and overseeing corrective actions, as necessary to bring an activity back into compliance.
- verifying that the limits of authorized construction work areas and locations of access roads are properly marked before clearing;
- verifying the location of drainage and irrigation systems;
- identifying erosion/sediment control and stabilization needs in all areas;
- locating dewatering structures and interceptor diversions to ensure they will not direct water into known cultural resource sites or locations of sensitive species;
- verifying that trench dewatering activities do not result in the deposition of sand, silt, and/or sediment near the point of discharge into a wetland or waterbody. If such deposition is occurring, the dewatering activity shall be stopped and the design of the discharge shall be changed to prevent reoccurrence;
- verifying the testing of subsoil and topsoil in agricultural and residential areas to measure compaction and determine the need for corrective action;
- advising the Chief Inspector when conditions (such as wet weather) make it advisable to restrict construction activities in agricultural areas;
- ensuring restoration of contours and topsoil;



- verifying that the soils imported for agricultural or residential use are noxious weed free certified;
- ensuring that temporary erosion controls are properly installed and maintained, daily if necessary;
- The Inspector/Certified Responsible Land Disturber shall provide for and document inspections at the following frequency: during or immediately following initial installation of erosion and sediment controls, at least once in every two week period, within 48 hours following a runoff producing storm event, and at the completion of the project.
- ensuring the repair of all ineffective temporary erosion control measures within 24 hours of identification;
- keeping records of compliance with the environmental conditions of the (EM&CP and any certificates) and other federal or state environmental permits during active construction and restoration;
- establishing a program to monitor the success of restoration. Implementation of this program may be transferred to (Field Services) upon completion of construction and restoration activities;
- looking for evidence of contamination and, if found, cease activities in that area and notify the Environmental Health & Safety department and the Natural Resource Permitting group and wait for further instruction. If the contamination is determined to be hazardous, an experienced hazardous waste contractor will be mobilized to handle the waste; the hazardous waste contractor will follow a site-specific health and safety plan and standard operating procedures for working in hazardous environments, which is maintained by the Environmental Health & Safety department; and
- verifying the location of signs and visible flagging marking the boundaries of wetlands, waterbodies and other environmental sensitive areas.

### **C. Environmental Training**

The Engineering & Construction Team Leader assigned to the construction activity and/or the Columbia employee in responsible charge, will be responsible for assuring that the Environmental Inspector(s), other inspectors and any contractor's foreman have been trained in all environmental aspects of the activity, and fully understands the environmental conditions contained in the activity's EM&CP.

The Natural Resource Permitting group staff will conduct training for construction personnel when sensitive resource issues are present, when permit/certificate conditions mandate, or when requested by the Team Leader.

#### **D. Contractor's Environmental Compliance Specialist (Environmental Foreman)**

For construction activities that utilize an outside contractor, the contractor will be required to provide at least one environmental compliance specialist. This specialist will become thoroughly familiar with Columbia's EM&CP for the activity.

The specialist will be responsible for the contractor's efforts to correctly install and maintain environmental control devices and for construction in environmentally sensitive areas. Contractor's specialist will work in cooperation with Columbia's employees responsible for environmental compliance.

The Contractor's Environmental Foreman must be available at all times during the project and have the appropriate number of available employees to adequately implement the project's EM&CP.

#### **E. Environmental Construction Management**

The Environmental Inspector and each functional inspector shall have the authority to stop work on a particular construction function to which they are assigned if it deviates from the environmental conditions of the activity's EM&CP. The deviation shall be reported immediately to the Columbia employee in responsible charge of the activity and the Environmental Inspector. The Columbia employee in responsible charge, the Engineering & Construction Team Leader and the Natural Resource Permitting group department will be responsible for the resolution of the deviation.

Stop work authority for the entire construction activity rests with the Columbia employee in responsible charge or the Engineering & Construction Team Leader.

The Natural Resource Permitting group may, from time to time, perform inspections of construction activities to review the implementation of the EM&CPs. The Natural Resource Permitting group will have stop work authority during these inspections should deviations from the activity's EM&CP occur. Any corrective actions that are required shall be taken as soon as possible.

#### **F. Environmental Variances**

Unapproved variances from an EM&CP and this ECS are not permitted. Any proposed variance from an EM&CP will require approval from the EM&CP preparer, prior to commencing the activity. The approval for a variance will be in writing. In instances where written approval is not practical (i.e., emergencies and weekends), verbal approval may be given provided that written confirmation is provided as soon as possible.

Any proposed variance from this ECS will require approval from the Natural Resource Permitting group prior to commencing the activity. Variances to the Virginia DCR's E&S Minimum Standards will require prior approval from their office.

## VII. Emergency Construction

In the event of an emergency, the Company employee in responsible charge will take such action as is necessary to contain the emergency giving due regard to minimizing environmental impact. In conjunction with other Columbia policies, the requirements contained in this ECS will be followed as close as possible.

<sup>1</sup>Will include all environmental and regulatory mandated surveys such as but not limited to, threatened and endangered species surveys, archeology surveys, wetland delineations etc.

<sup>2</sup>Deviations that involve measures different from those contained in this ECS will only be permitted by written approval from the Natural Resource Permitting group. The Natural Resource Permitting group may be required to obtain written approval from the Director of the Office of Energy Projects (OEP) (Federal Energy Regulatory Commission), or his/her designee, unless specifically required in writing by another Federal, state, or Native American land management agency for the portion of the project on its land. The Natural Resource Permitting group shall coordinate the filing of other agency requirements with the Secretary of the Commission (Secretary). This filing shall be prior to construction.

## VIII. Definition of Terms

**AGRICULTURAL LANDS:** Permanent or rotated croplands, hayfields, and pastures.

**COLUMBIA:** Columbia Gas Transmission

**COE:** U.S. Army Corps of Engineers

**CONSTRUCTION WORK AREA:** Construction work areas include permanent and temporary ROW, contractor's yards, pipe and materials storage yards, and access roads.

**ECS:** Environmental Construction Standards

**ENVIRONMENTAL INSPECTOR:** The Inspector responsible for environmental compliance on a construction project.

**EPA:** Environmental Protection Agency

**FWS:** U.S. Fish and Wildlife Service

**EM&CP:** Environmental Management and Construction Plan

**EXCEPTIONAL VALUE WATER(S):** A stream or waterbody which constitutes an outstanding national, State, regional or local resource, such as waters of national, State or county parks or forests, or waters which are used as a source of unfiltered potable water supply, or waters of wildlife refuges or State game lands, or waters which have been characterized by the Fish Commission as "Wilderness Trout Streams." and other waters of substantial recreational or ecological significance.

**FINAL GRADING:** Includes returning the construction work area as closely as practical to its original contour, redistributing conserved topsoil, soil compaction testing in agricultural lands, and installing final interceptor diversions.

**HIGH QUALITY STREAM:** A cold water fishery or significant warm water fishery as designated by a state resource agency.

**HORIZONTAL DIRECTIONAL DRILL:** Drilling method used for relatively long pipe installations and usually under environmentally sensitive sites such as large streams and wetlands. This method usually requires extra workspace for the drilling rig to set up and for the pipeline section to be welded together. After a pilot hole is drilled, the hole is reamed larger several times (depending on the diameter of the pipeline to be installed) by the drilling rig. When the desired diameter is achieved, the pipeline is pulled into the hole by the drilling rig.

**IMMEDIATE:** Without interval of time; "right now".

**INSPECTOR:** Collectively: the Chief Inspector, Environmental Inspector, Environmental Coordinator, or any other inspector assigned to do an environmental task.

**INTERMITTENT WATERBODY:** A waterbody channel which generally carries water in the spring or immediately after a rain event; designated on topographic maps and environmental construction drawings with a broken line.

**INTERMEDIATE WATERBODY:** A waterbody greater than 10 feet at the water's edge at the time of construction.

**LOW-GROUND-WEIGHT:** Construction equipment that is designed "specifically for" or "frequently used in" areas where compaction and sinking is to be minimized. This equipment can be less than 5 lbs/in<sup>2</sup> or contain wider tracks than the standard minimum size width tracks for the model equipment to be used.

**MAJOR WATERBODY:** A waterbody greater than 100 feet wide at the water's edge at the time of construction.

**MINOR WATERBODY:** A waterbody less than or equal to 10 feet wide at the water's edge at the time of construction.

**MSDS:** Material Safety Data Sheet

**NRCS:** Natural Resource Conservation Service

**NOISE SENSITIVE AREA:** Includes residences, schools, churches, cemeteries, hospitals, farms, camping facilities and outdoor amphitheatres and playgrounds.

**ORV:** Off-road vehicle.

**PERENNIAL WATERBODY:** A waterbody which generally flows all year in years of normal rainfall; waterbody level is generally lowest in the fall, highest in the spring; designated with a solid line on topographic maps and environmental construction drawings.

**PROMPTLY:** By the end of the work day.

**RESTORATION:** Includes fertilizing, liming, disking, seeding and mulching, and crimping mulch.

**RIVER:** A waterbody which is 100 feet wide or more.

**ROW:** Right-of-way.

**SCARIFY:** To make shallow cuts into the soil surface. This should be accomplished with a disk, rake, tracked equipment (grouzers) or other suitable means.

**SEDIMENT FILTER DEVICE:** Properly embedded silt fence or staked bales (Figures 7 & 8).

**SLICK BORE:** Drilling method for rather short pipe installations (usually less than 100 feet and usually for road crossing and railroad crossing installations). This method requires the excavation of an entrance bore pit to set up the drilling machine and usually requires extra work space for spoil and equipment storage. After the hole is drilled, the pipeline is installed by sliding sections into the hole and welding each section together in the bore pit. This method does not require casing.

**SPCC:** Spill Prevention Control and Countermeasure Plan

**STEEP SLOPE:** Slope of 33% or greater.

**TEMPORARY STABILIZATION:** Includes installing temporary interceptor diversions and sediment filter devices, mulching critical areas and at times, seeding to hold soil in place until final grading and restoration can be accomplished.

**UPLAND CONSTRUCTION:** All areas which are not waterbodies, rivers, streams, or wetlands.

**WATERBODY:** Includes any natural or artificial waterbody, river, or drainage with perceptible flow at the time of crossing, and other permanent waterbodies such as ponds and lakes.

**WETLAND:** An area of special concern with soils prone to holding water for long periods of time, generally also characterized by distinctive plants such as rushes, sedges, cattails, or certain trees. Includes any area that satisfies the requirements of the current Federal methodology for identifying and delineating wetlands.

\*Includes all grammatical variations of each term.

VIRGINIA PHYSIOGRAPHIC PROVINCES  
REFERENCE GUIDE FOR  
TABLES 2c, 2d, and 2e

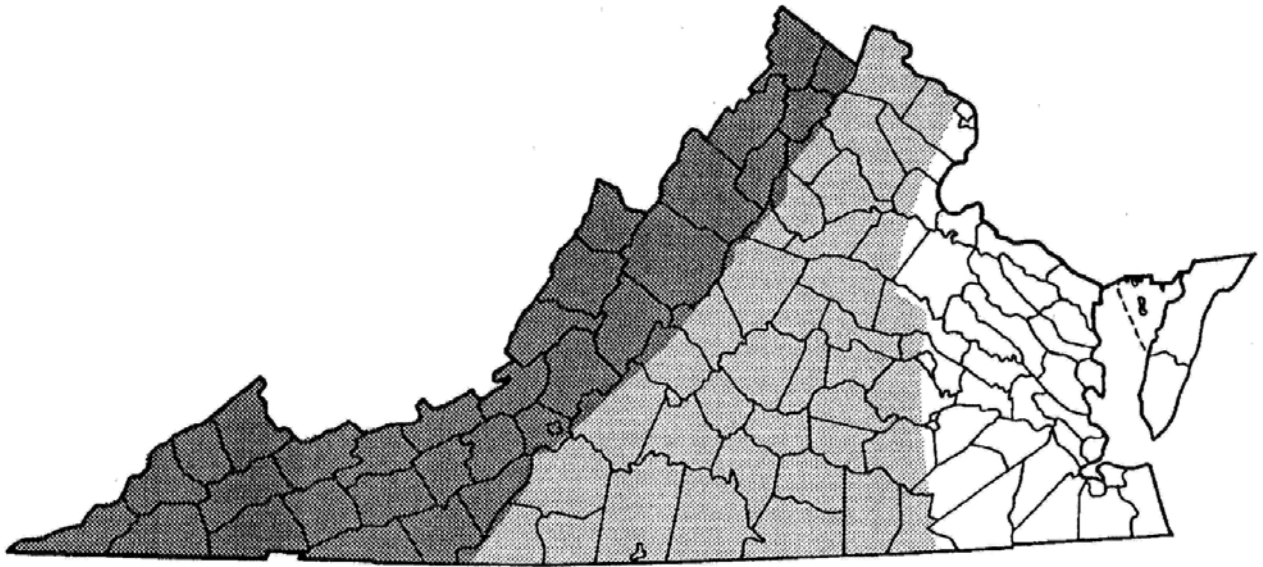

APPALACHIAN

PIEDMONT

COASTAL PLAIN

**PHYSIOGRAPHIC PROVINCES IN VIRGINIA**

**IX. Tables**

**Table 2a**

**SEED MIX FOR TEMPORARY STABILIZATION**

<b>Type</b>		<b>Rate (lbs/acre)</b>
Seed	Annual Rye or German Millet <sup>1</sup>	80
Mulch	Hay or Straw	6000
<sup>1</sup> Use German Millet between May 1 and August 31		

**Table 2b**

**SEED MIX REQUIREMENTS IN WETLANDS**

<b>Type</b>		<b>Rate (lbs/acre)</b>
Seed*	Annual Rye	80
* Annual Rye is used as a temporary revegetative measure until indigenous plants re-establish cover. A monitoring program will be in effect to insure adequate cover is established.		

**TABLE 2c  
SITE SPECIFIC SEEDING MIXTURES  
FOR APPALACHIAN/MOUNTAIN AREA**

<u>Minimum Care Lawn</u>	<u>Total Lbs. Per Acre</u>
<ul style="list-style-type: none"> <li>- Commercial or Residential</li> <li style="padding-left: 20px;">- Turf-Type Tall Fescue</li> <li style="padding-left: 20px;">- Improved Perennial Ryegrass *</li> <li style="padding-left: 20px;">- Kentucky Bluegrass</li> </ul>	200-250 lbs. 90-100% 0-10% 0-10%
<u>High-Maintenance Lawn</u>	
Minimum of three (3) up to five (5) varieties of bluegrass from approved list for use in Virginia	125 lbs.
<u>General Slope (3:1 or less)</u>	
<ul style="list-style-type: none"> <li>- Tall Fescue</li> <li>- Red Top Grass</li> <li>- Seasonal Nurse Crop **</li> </ul>	128 lbs. 2 lbs. <u>20 lbs.</u> 150 lbs.
<u>Low-Maintenance Slope (Steeper than 3:1)</u>	
<ul style="list-style-type: none"> <li>- Tall Fescue</li> <li>- Red Top Grass</li> <li>- Seasonal Nurse Crop **</li> <li>- Crownvetch ***</li> </ul>	108 lbs. 2 lbs. 20 lbs. <u>20 lbs.</u> 150 lbs.

\* Perennial Ryegrass will germinate faster and at lower soil temperatures than fescue, thereby providing cover and erosion resistance for seedbed.

\*\* Use seasonal nurse crop in accordance with seeding dates as stated below:

March, April through May 15 <sup>th</sup> .....	Annual Rye
May 16 <sup>th</sup> through August 15 <sup>th</sup> .....	Foxtail Millet
August 16 <sup>th</sup> through September, October.....	Annual Rye
November through February .....	Winter Rye

\*\*\* If Flatpea is used, increase to 30 lbs./acre. All legume seed must be properly inoculated. Weeping Lovegrass may also be included in any slope or low-maintenance mixture during warmer seeding periods; add 10-20 lbs./acre in mixes.



**TABLE 2d  
SITE SPECIFIC SEEDING MIXTURES FOR PIEDMONT AREA**

<u>Minimum Care Lawn</u>	<u>Total Lbs. Per Acre</u>
<ul style="list-style-type: none"> <li>- Commercial or Residential</li> <li style="padding-left: 20px;">- Turf-Type Tall Fescue</li> <li style="padding-left: 20px;">- Improved Perennial Ryegrass</li> <li style="padding-left: 20px;">- Kentucky Bluegrass</li> </ul>	<p>175-200 lbs.</p> <p style="padding-left: 20px;">95-100%</p> <p style="padding-left: 20px;">0-5%</p> <p style="padding-left: 20px;">0-5%</p>
<u>High-Maintenance Lawn</u>	200-250 lbs.
<ul style="list-style-type: none"> <li>- Turf-Type Tall Fescue</li> </ul>	100%
<u>General Slope (3:1 or less)</u>	
<ul style="list-style-type: none"> <li>- Tall Fescue</li> <li>- Red Top Grass</li> <li>- Seasonal Nurse Crop *</li> </ul>	<p>128 lbs.</p> <p>2 lbs.</p> <p><u>20 lbs.</u></p> <p>150 lbs.</p>
<u>Low-Maintenance Slope (Steeper than 3:1)</u>	
<ul style="list-style-type: none"> <li>- Tall Fescue</li> <li>- Red Top Grass</li> <li>- Seasonal Nurse Crop *</li> <li>- Crownvetch **</li> </ul>	<p>108 lbs.</p> <p>2 lbs.</p> <p>20 lbs.</p> <p><u>20 lbs.</u></p> <p>150 lbs.</p>

\* Use seasonal nurse crop in accordance with seeding dates as stated below:

February 16 <sup>th</sup> through April.....	Annual Rye
May 1 <sup>st</sup> through August 15 <sup>th</sup> .....	Foxtail Millet
August 16 <sup>th</sup> through October.....	Annual Rye
November through February 15 <sup>th</sup> .....	Winter Rye

\*\* Substitute Sericea lespedeza for Crownvetch east of Farmville, Va. (May through September use hulled Sericea, all other periods, use unhulled Sericea). If Flatpea is used in lieu of Crownvetch, increase rate to 30 lbs./acre. All legume seed must be properly inoculated. Weeping Lovegrass may be added to any slope or low-maintenance mix during warmer seeding periods; add 10-20 lbs./acre in mixes.

**TABLE 2e**  
**SITE SPECIFIC SEEDING MIXTURES FOR COASTAL PLAIN AREA**

<u>Minimum Care Lawn</u>	<u>Total Lbs.</u> <u>Per Acre</u>
<ul style="list-style-type: none"> <li>- Commercial or Residential               <ul style="list-style-type: none"> <li>- Turf-Type Tall Fescue</li> </ul> </li> <li style="text-align: center; padding: 0 10px;"><b>or</b></li> <li>- Common Bermudagrass **</li> </ul>	<p>175-200 lbs.</p> <p>75 lbs.</p>
<u>High-Maintenance Lawn</u>	
<ul style="list-style-type: none"> <li>- Turf-Type Tall Fescue</li> <li style="text-align: center; padding: 0 10px;"><b>or</b></li> <li>- Hybrid Bermudagrass (seed) **</li> <li style="text-align: center; padding: 0 10px;"><b>or</b></li> <li>- Hybrid Bermudagrass (by other vegetative establishment method, see Std. &amp; Spec. 3.34)</li> </ul>	<p>200-250 lbs.</p> <p>40 lbs. (unhulled)</p> <p>30 lbs. (hulled)</p>
<u>General Slope (3:1 or less)</u>	
<ul style="list-style-type: none"> <li>- Tall Fescue</li> <li>- Red Top Grass</li> <li>- Seasonal Nurse Crop *</li> </ul>	<p>128 lbs.</p> <p>2 lbs.</p> <p><u>20 lbs.</u></p> <p>150 lbs.</p>
<u>Low-Maintenance Slope (Steeper than 3:1)</u>	
<ul style="list-style-type: none"> <li>- Tall Fescue</li> <li>- Common Bermudagrass **</li> <li>- Red Top Grass</li> <li>- Seasonal Nurse Crop *</li> <li>- Sericea Lespedeza **</li> </ul>	<p>93-108 lbs.</p> <p>0-15 lbs.</p> <p>2 lbs.</p> <p>20 lbs.</p> <p><u>20 lbs.</u></p> <p>150 lbs.</p>

\* Use seasonal nurse crop in accordance with seeding dates as stated below:

February, March through April.....	Annual Rye
May 1 <sup>st</sup> through August.....	Foxtail Millet
September, October through November 15 <sup>th</sup> .....	Annual Rye
November 16 <sup>th</sup> through January.....	Winter Rye

\*\* May through October, used hulled seed. All other seeding periods, use unhulled seed. Weeping Lovegrass may be added to any slope or low-maintenance mix during warmer seeding periods; add 10-20 lbs./acre in mixes.

X. Figures

A. Figure 1 – Typical Upland Pipeline Construction Sequence

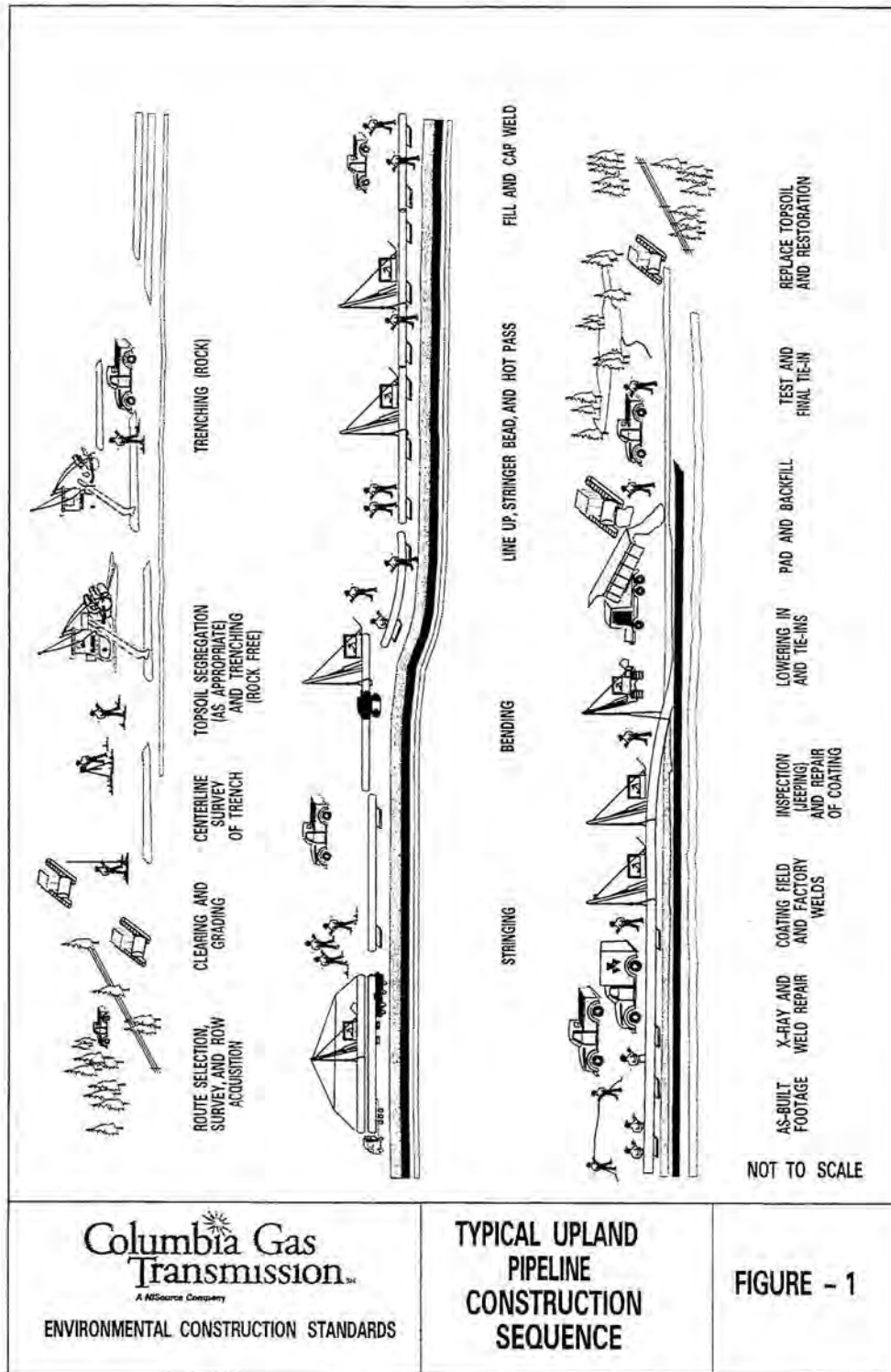

**B. Figure 2 – Typical 75ft. Construction Right-of-Way**

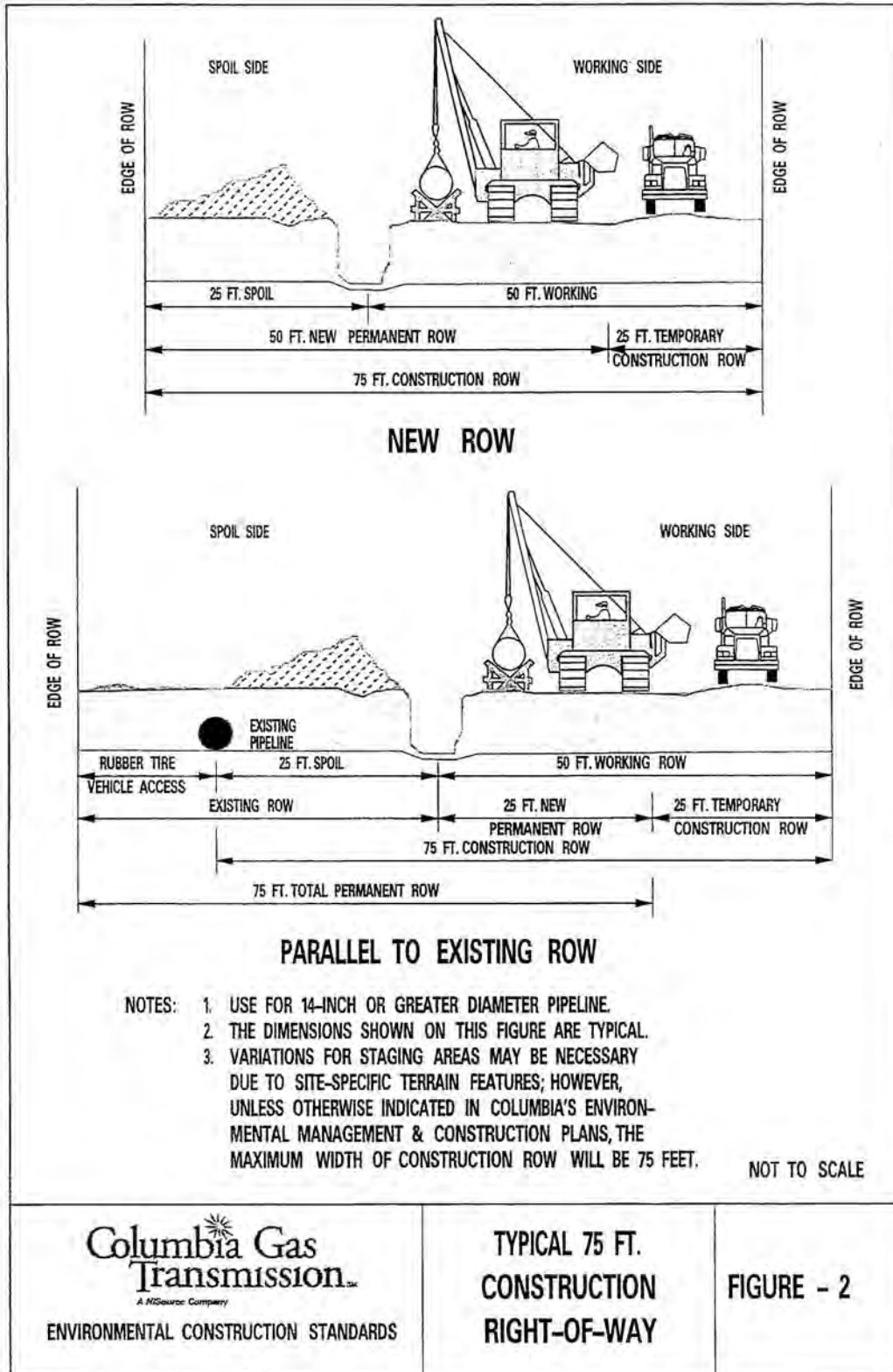

C. Figure 3 – Typical 50ft. Construction Right-of-Way

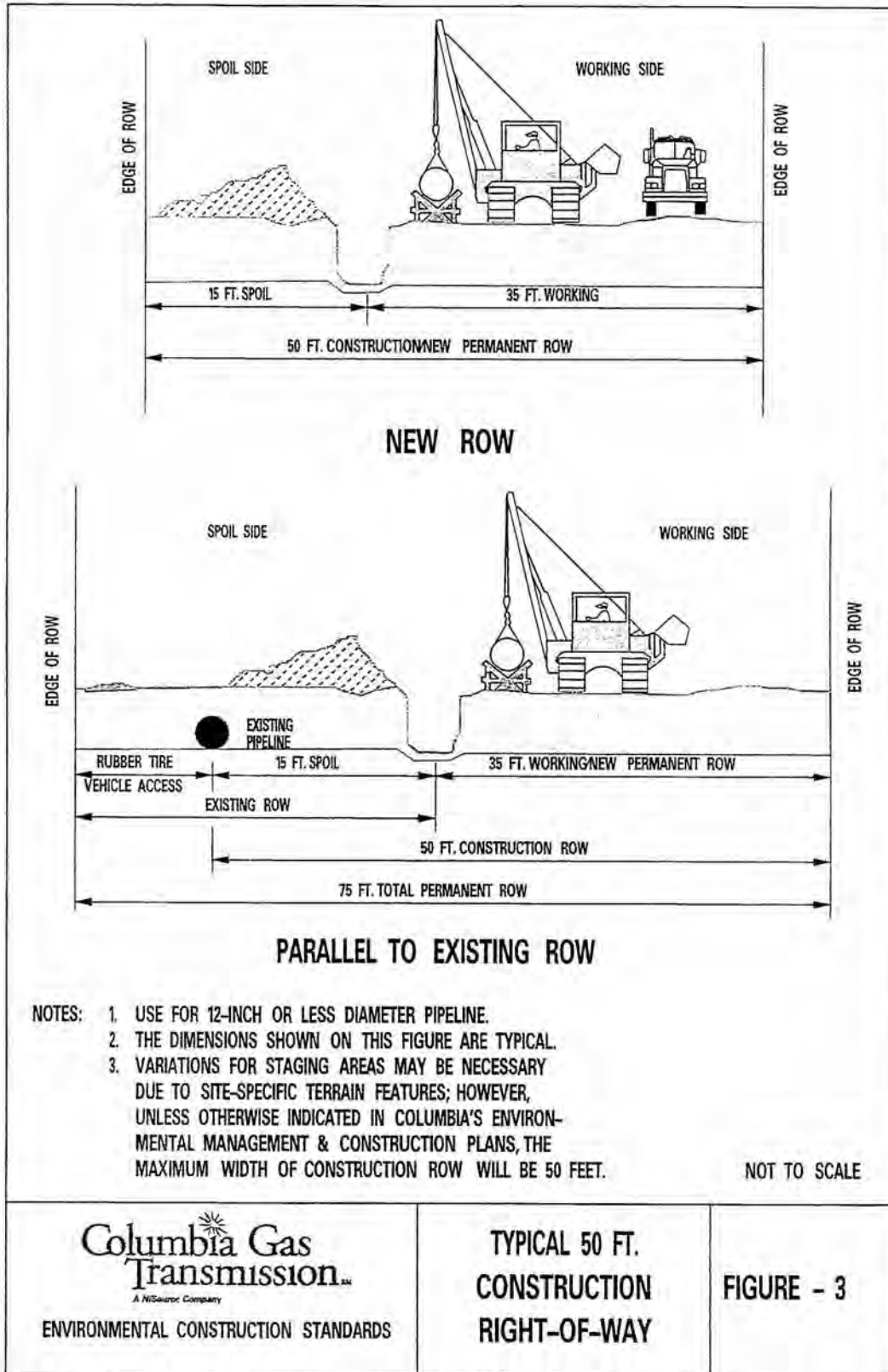

D. Figure 4 – Temporary Construction Gate

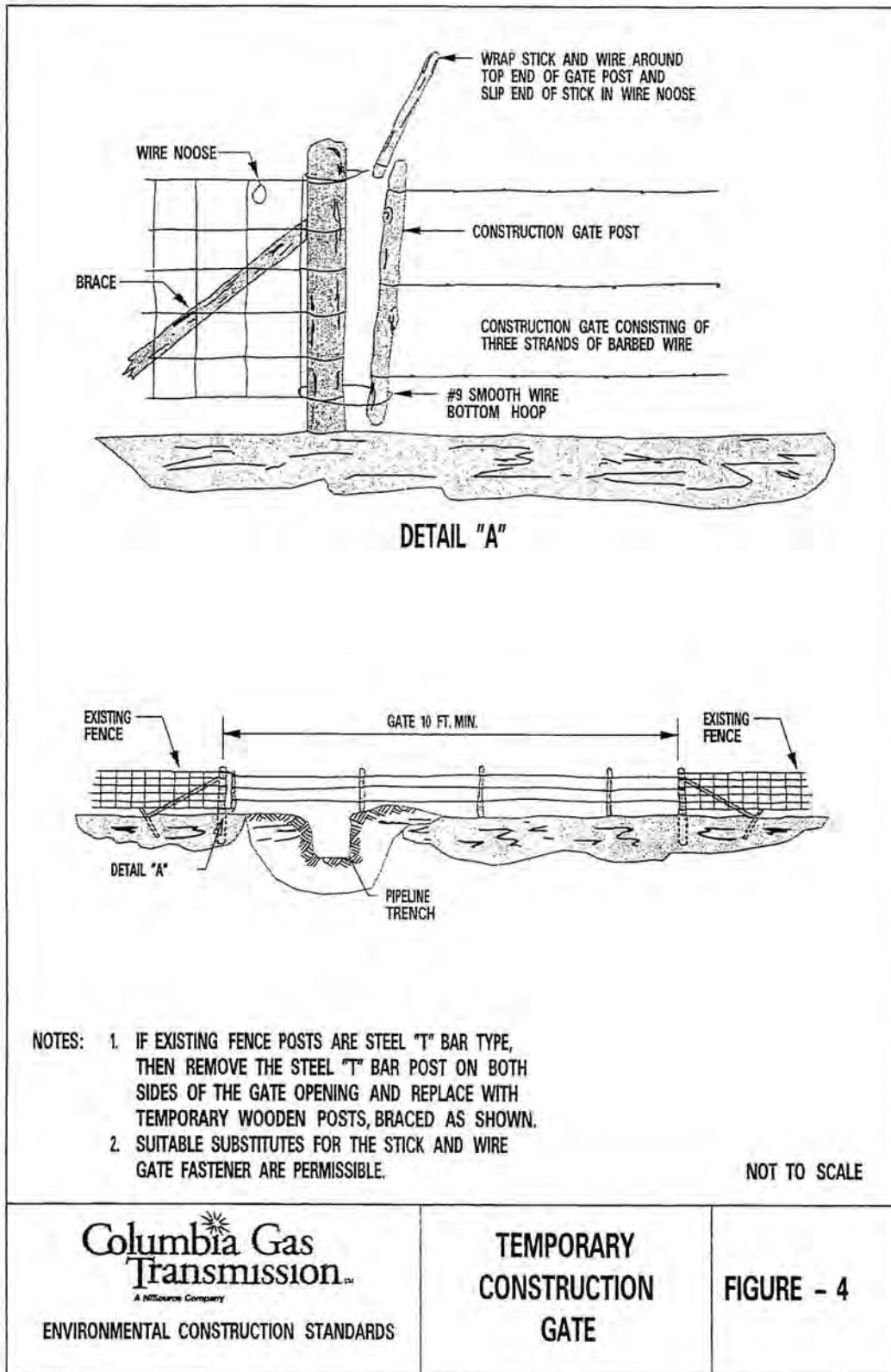

**Columbia Gas Transmission**  
A NISOURCE Company

ENVIRONMENTAL CONSTRUCTION STANDARDS

TEMPORARY  
CONSTRUCTION  
GATE

FIGURE - 4

E. Figure 5 – Typical Topsoil Conservation

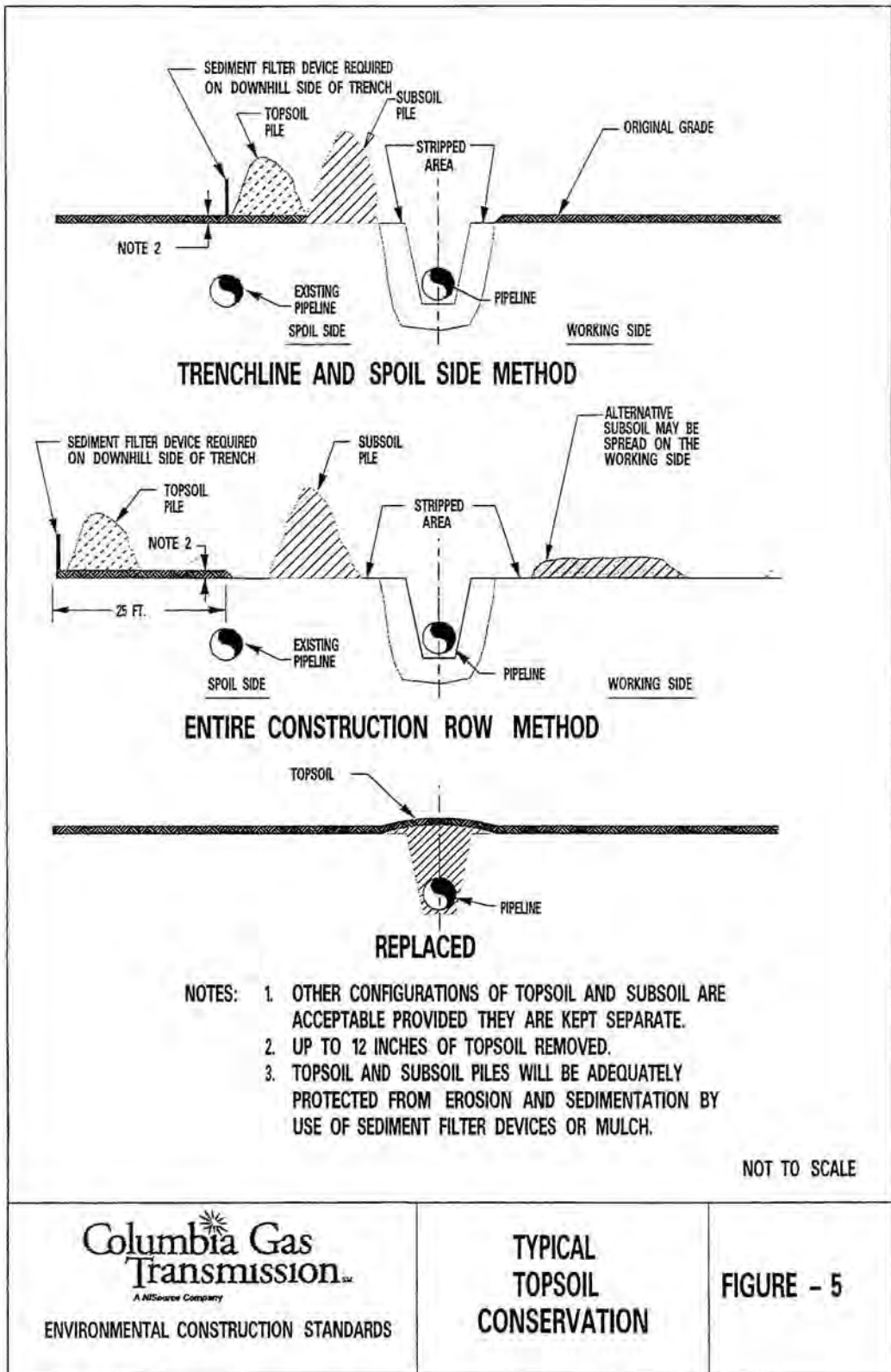

F. Figure 6A – Interceptor Diversions

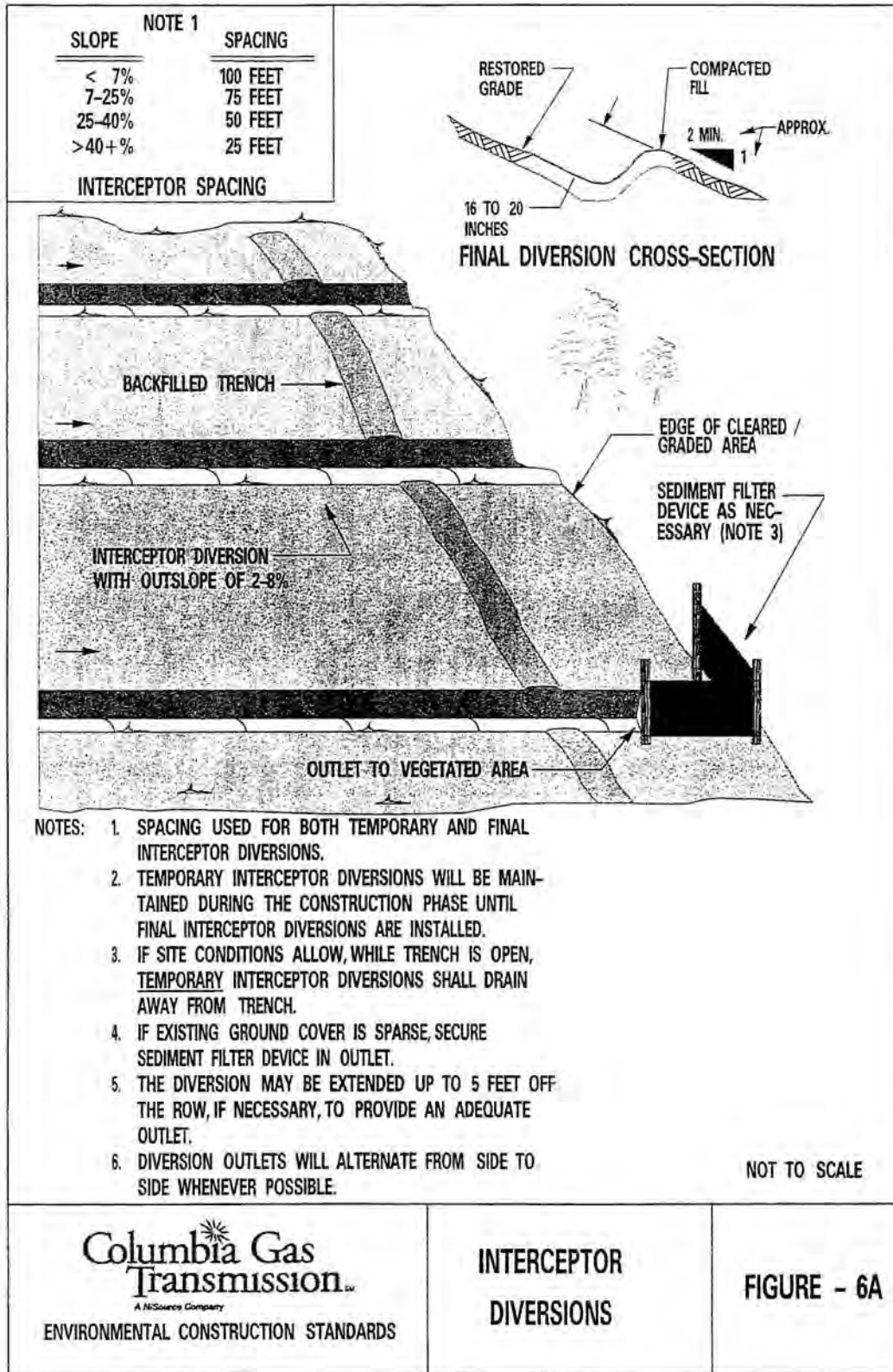



## G. Figure 6B – Interceptor Diversions

### INTERCEPTOR DIVERSIONS

Interceptor diversions are the most common and effective device used for erosion control on construction ROW. During construction, temporary diversions are installed to control water on the graded ROW. During restoration final diversions are installed to protect the ROW from erosion until the vegetation reestablishes on the disturbed area.

Temporary diversions are generally made by building a curb 8 to 14 inches high across the ROW. The curbs are shaped to allow passage of construction equipment and inspector vehicles. The diversion should have a gradient of 2%–8%, and must drain either into the trench or off the ROW. If site conditions allow, while trench is open, temporary Interceptor Diversion shall drain away from trench. Where water is directed off the ROW, the outlet will be protected by a sediment filter device or heavy vegetation. Temporary diversions may be broken down by construction equipment during the workday, but will be restored by the end of each day. Temporary diversions will be spaced along the ROW in accordance with Figure 6A. The actual number of temporary diversions may vary from that of final diversions because the construction ROW's artificial grade may reduce the slope. Temporary diversions which will not be subject to construction equipment or vehicular traffic should be stabilized by temporary seeding and mulching.

Final diversions typically consist of a curb 16 to 20 inches high below a shallow swale. The curb is constructed of compacted earth fill with side slopes of 2:1 or flatter to allow passage of maintenance equipment. The diversions should extend across the entire ROW and drain water with a 2% to 8% gradient. The outlets of final diversions are stabilized with sediment filter devices, rock, brush, or heavy vegetation. Final diversions will be spaced along the ROW in accordance with Figure 6A (or as shown on the Environmental Construction Drawings), and will tie into existing diversions where present. In places where final grade creates side slopes or slopes which break in more than one direction, diversion installation may need to vary to create an outslope of 2% which will carry water off the ROW.

Alternative diversion construction may be used in areas where an earthen diversion is impractical. In these instances, temporary diversions may be constructed with sediment filter devices.

H. Figure 7 – Sediment Filter Device Silt Fencing

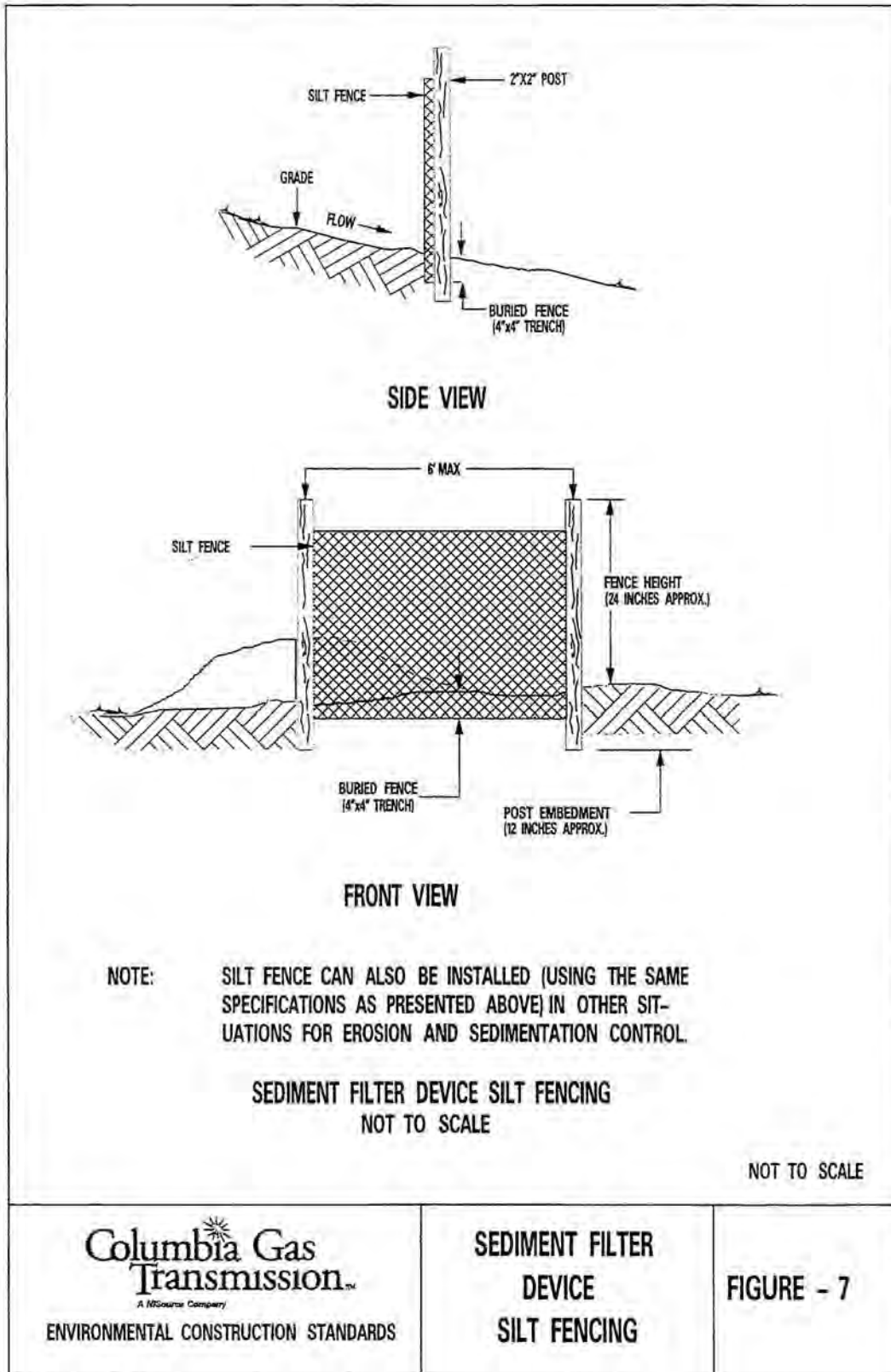

I. Figure 8 – Sediment Filter Device Staked Bales

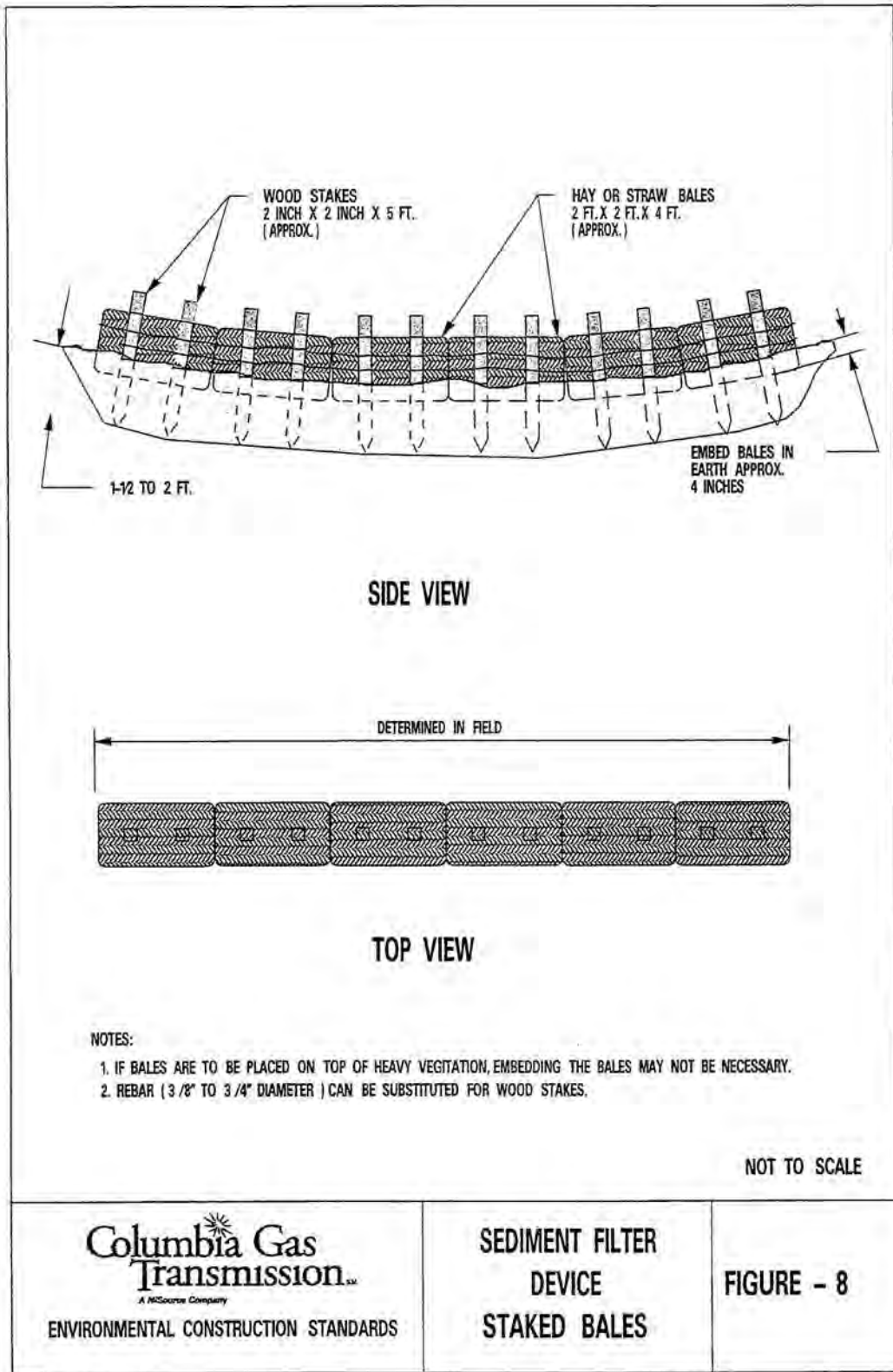

**J. Figure 9 – Temporary Road Entrance Rock Pads**

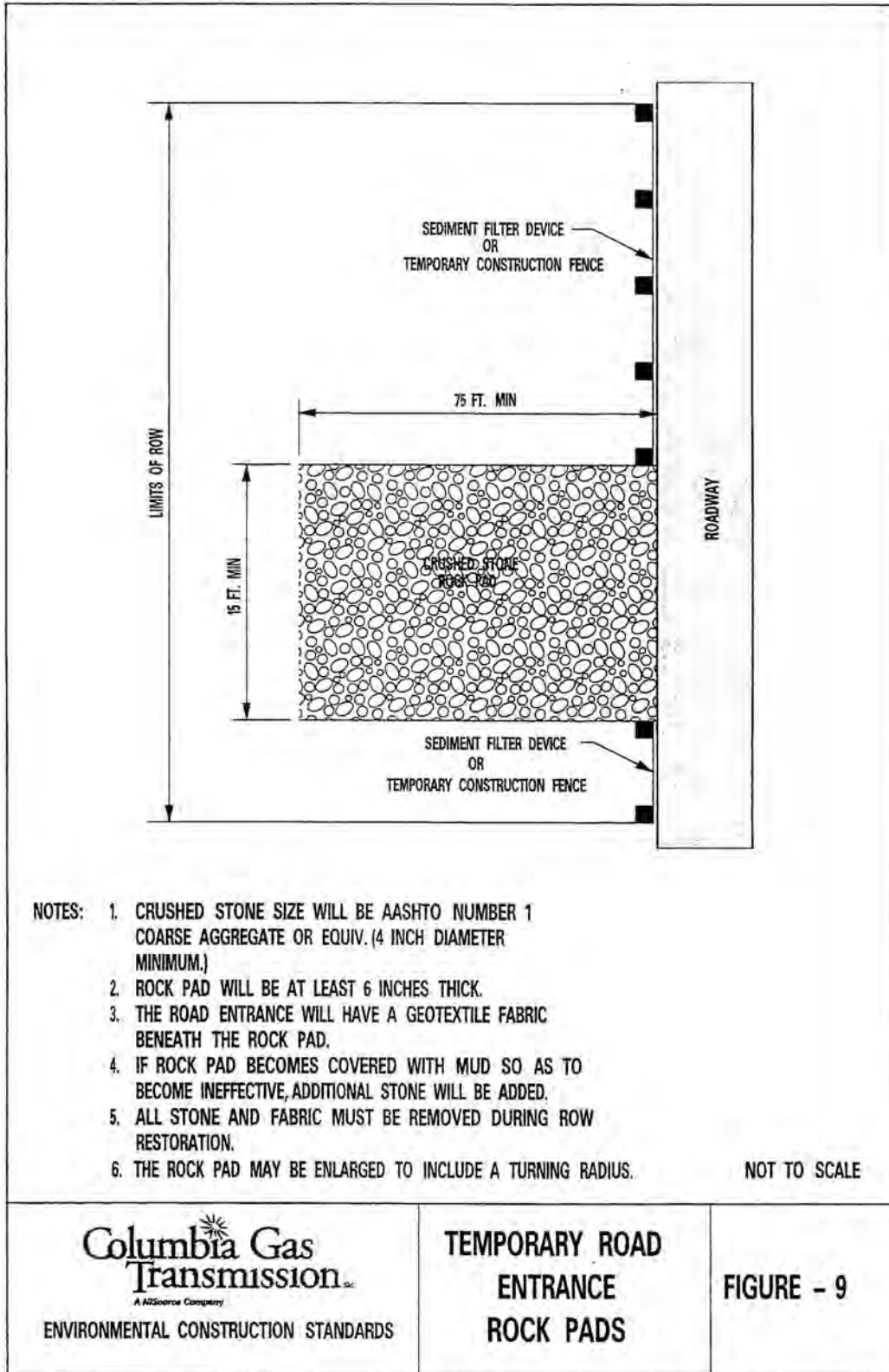

**K. Figure 10 – Temporary Road Entrance Terra-Mats**

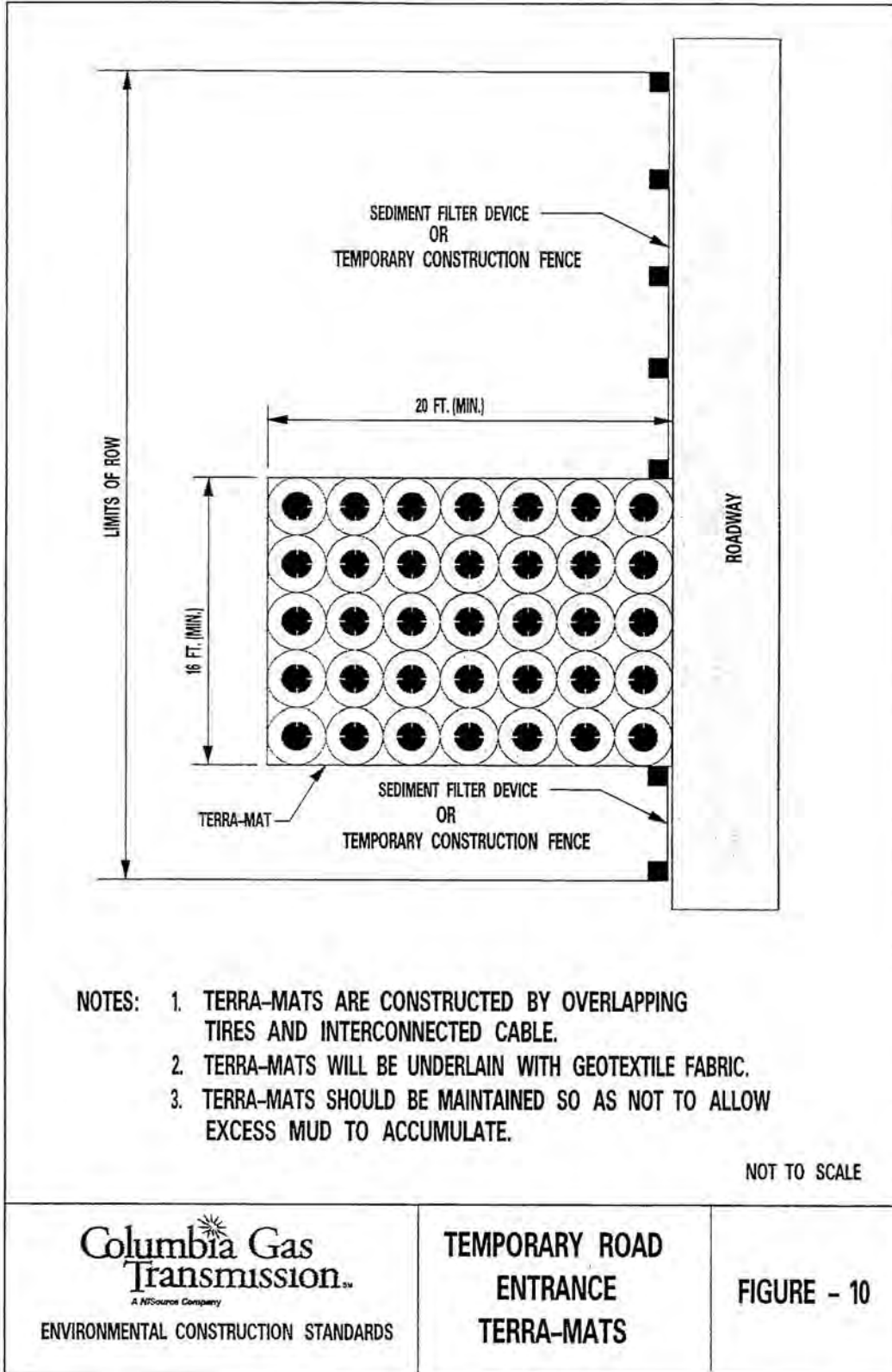

L. Figure 11 – Temporary Road Entrance Board Road

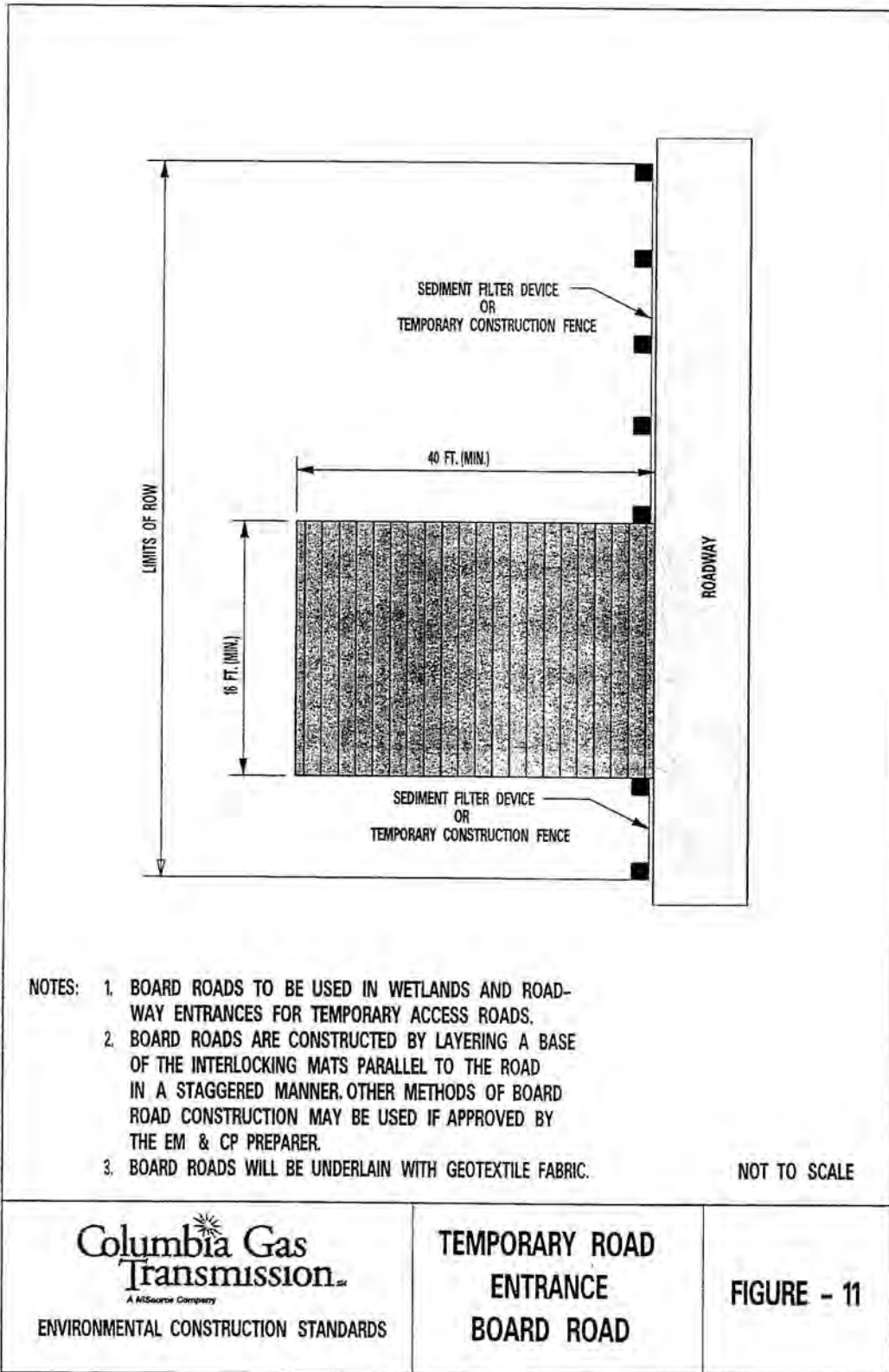

M. Figure 12 – Typical Erosion Control Measures at Road Crossings

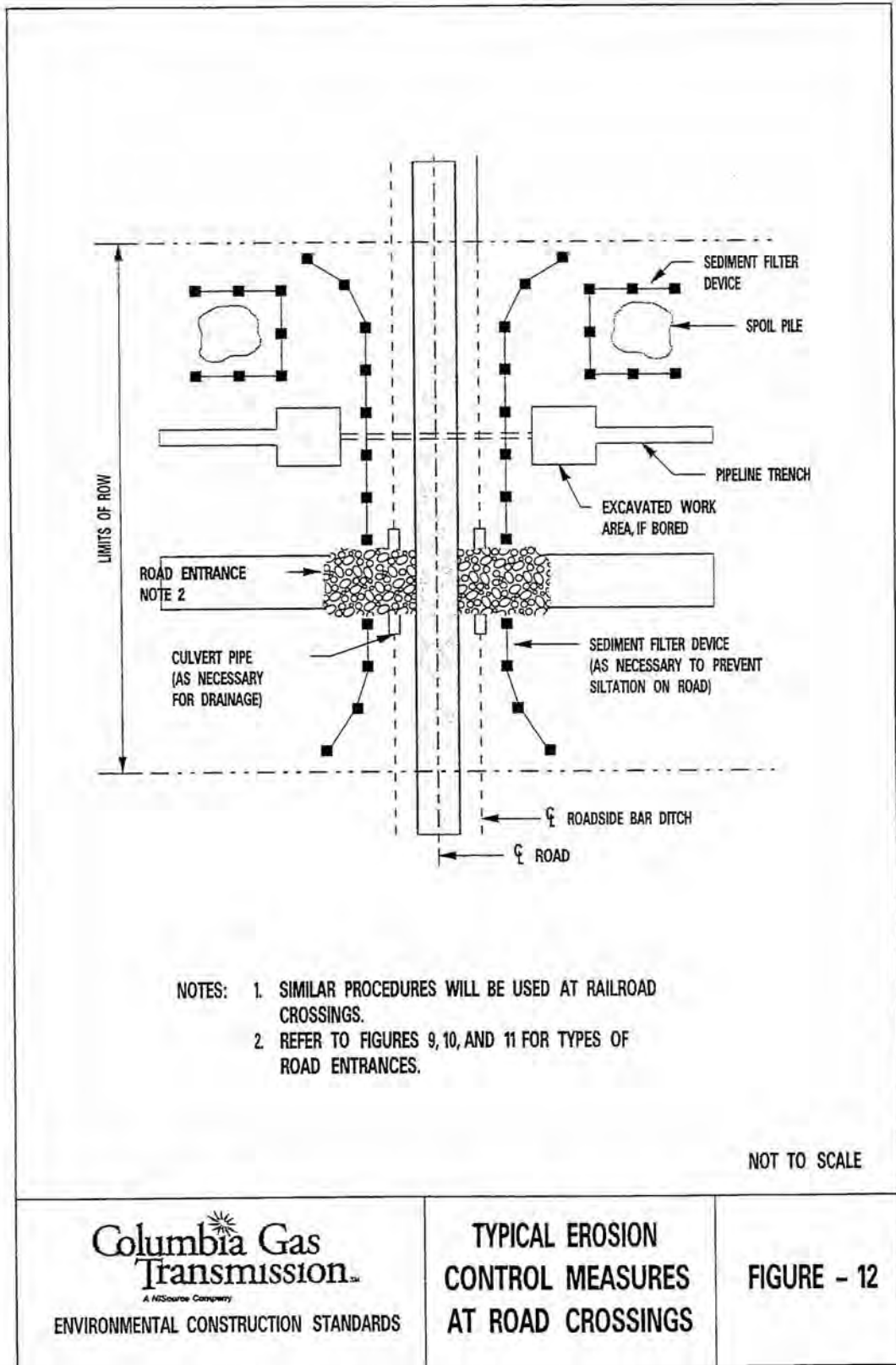

**N. Figure 13 – Trenchline Barriers and Breakers**

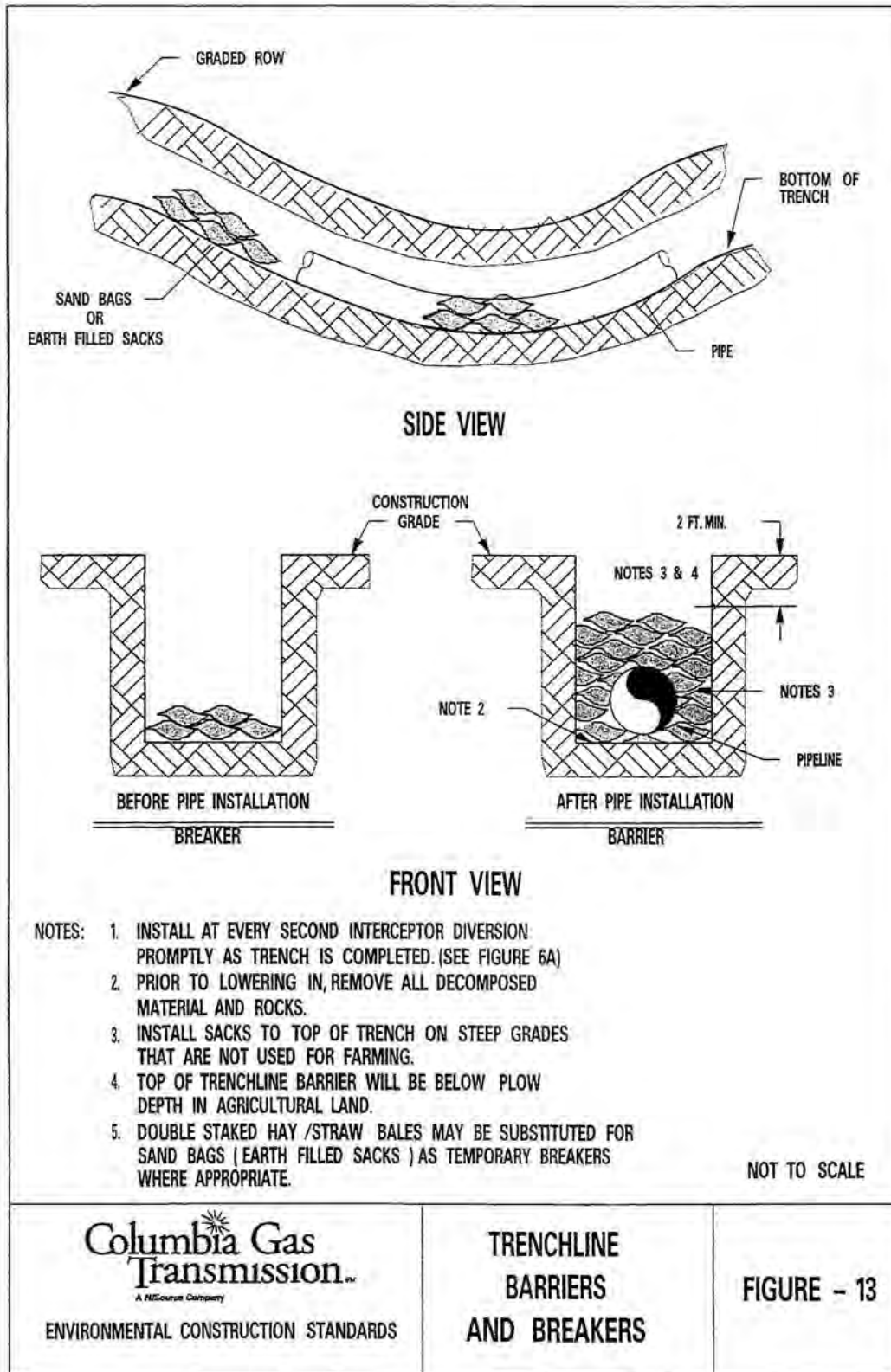



O. Figure 14A – Sediment Trap

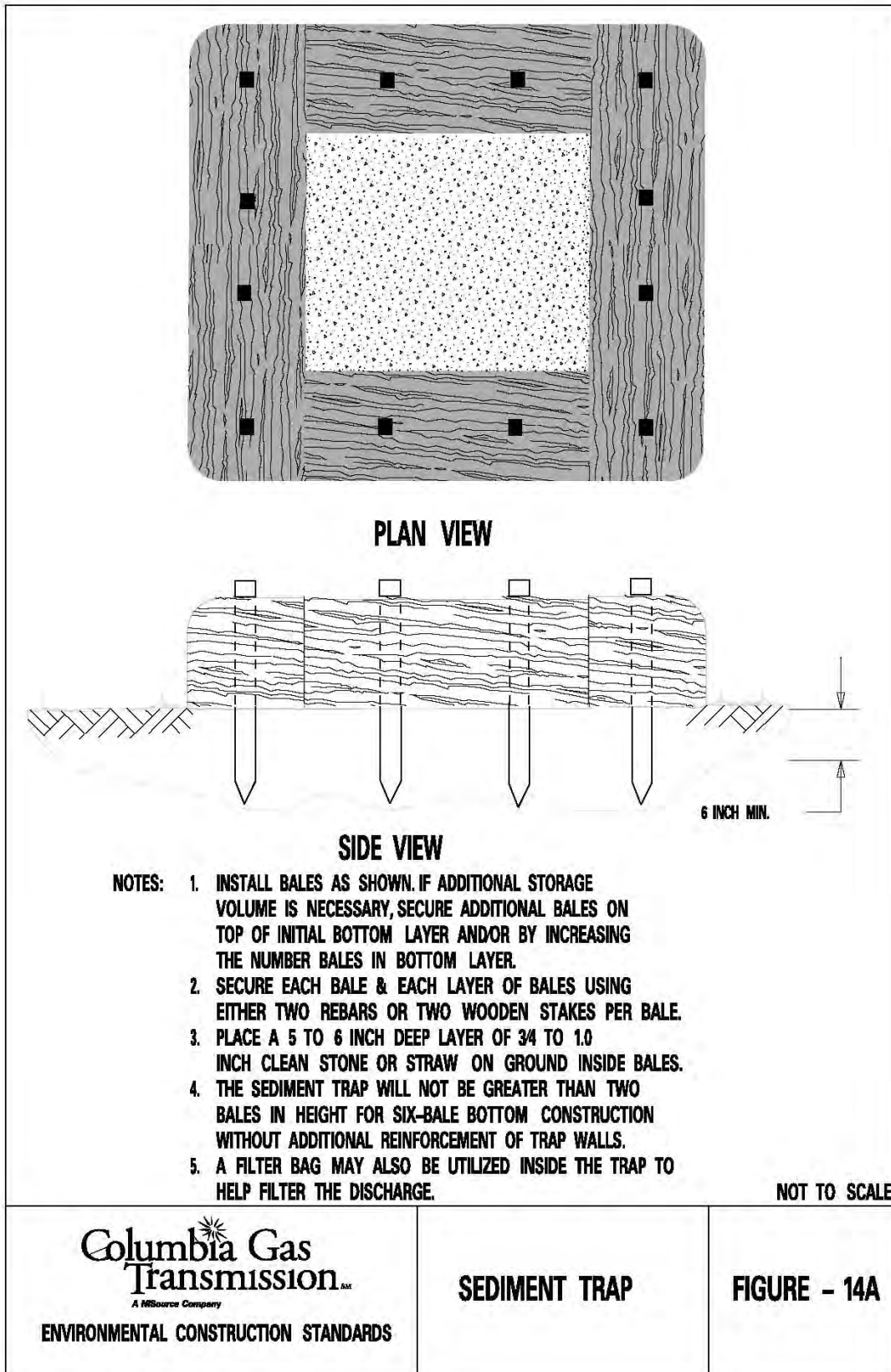

**P. Figure 14B – Filter Bag**

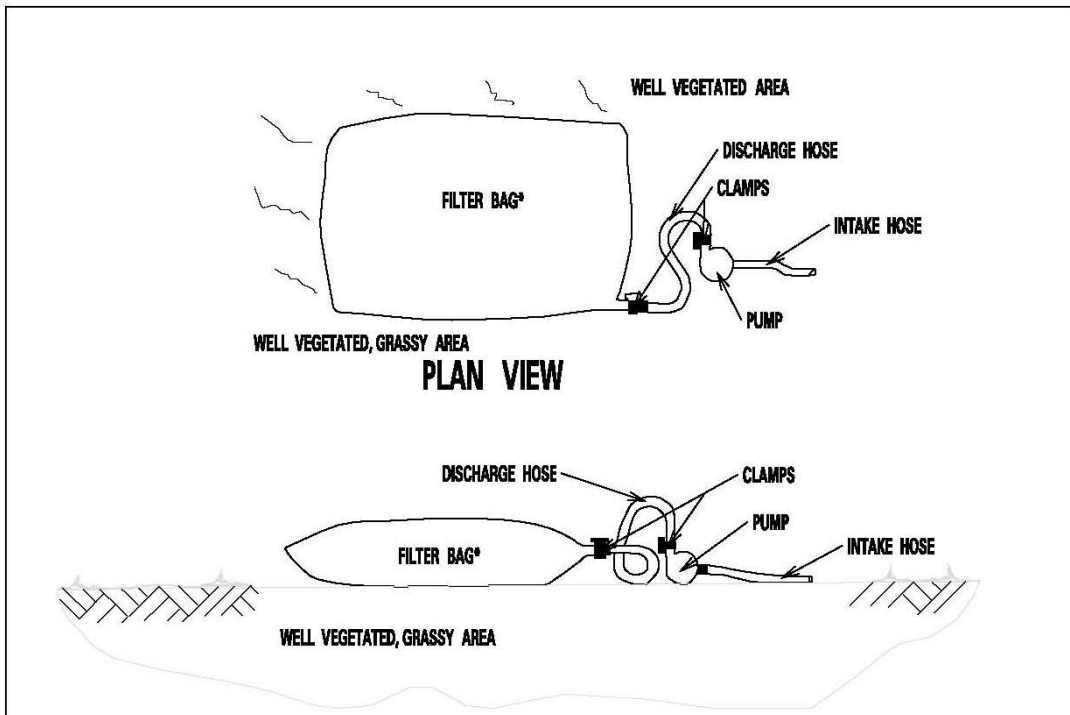

**SIDE VIEW**

- NOTES:**
1. FILTER BAGS SHALL BE MADE FROM NON-WOVEN GEOTEXTILE MATERIAL SEWN WITH HIGH STRENGTH, DOUBLE STITCHED "J" TYPE SEAMS. THEY SHALL BE CAPABLE OF TRAPPING PARTICLES LARGER THAN 150 MICRONS.
  2. BAGS MUST BE PLACED WITHIN THE PERMITTED AREA IF ACCESSING THE BAG WITH MACHINERY IS REQUIRED FOR DISPOSAL PURPOSES. FILTER BAGS SHALL BE REPLACED WHEN THEY BECOME 1/2 FULL OF SEDIMENT. SPARE BAGS SHALL BE KEPT AVAILABLE FOR REPLACEMENT OF THOSE THAT HAVE FAILED OR ARE FILLED.
  3. BAGS SHOULD BE LOCATED IN WELL-VEGETATED (GRASSY) AREAS, AND DISCHARGE ONTO STABLE, EROSION RESISTANT AREAS. WHERE THIS IS NOT POSSIBLE, A GEOTEXTILE FLOW PATH CAN BE PROVIDED OR ALLOW DISCHARGE FROM BAG TO FLOW THROUGH A SERIES OF SEDIMENT LOGS ETC... BAGS CAN BE USED INSIDE SEDIMENT TRAPS (FIGURE 14A).
  4. BAGS SHALL NOT BE PLACED ON SLOPES GREATER THAN 5%.
  5. THE PUMP DISCHARGE HOSE SHALL BE INSERTED INTO THE BAGS IN THE MANNER SPECIFIED BY THE MANUFACTURER AND SECURELY CLAMPED. DO NOT ALTER OR CUT BAGS.

NOT TO SCALE

<p style="text-align: center;">   <b>Columbia Gas Transmission</b>  <small>A NBSource Company</small>  <b>ENVIRONMENTAL CONSTRUCTION STANDARDS</b> </p>	<p style="text-align: center;"><b>FILTER BAG (DIRT BAG)</b></p>	<p style="text-align: center;"><b>FIGURE - 14B</b></p>
--	---	--

**Q. Figure 15 – Field Tile Replacement Methods**

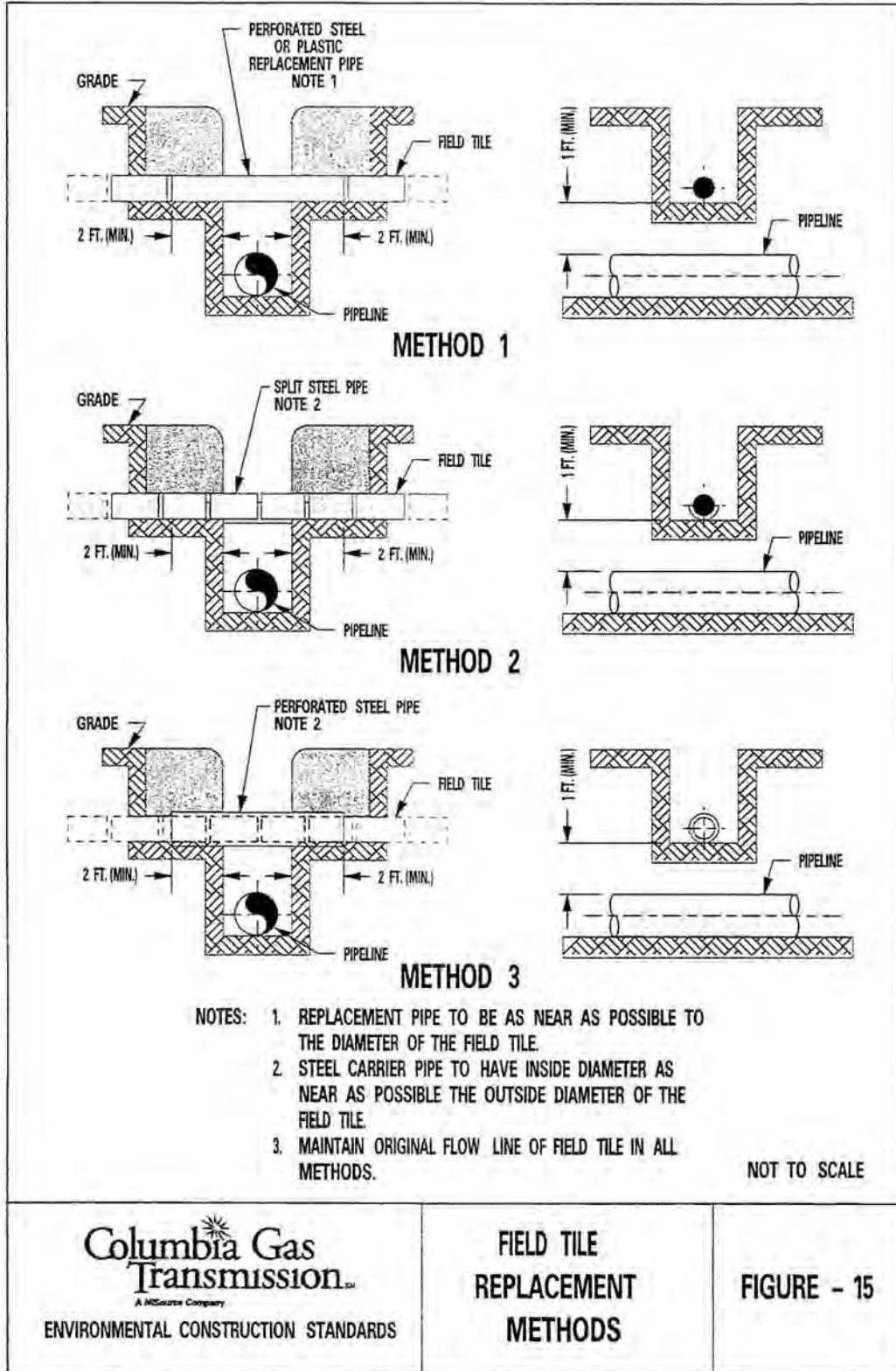

R. Figure 16 – Erosion Control Blanket

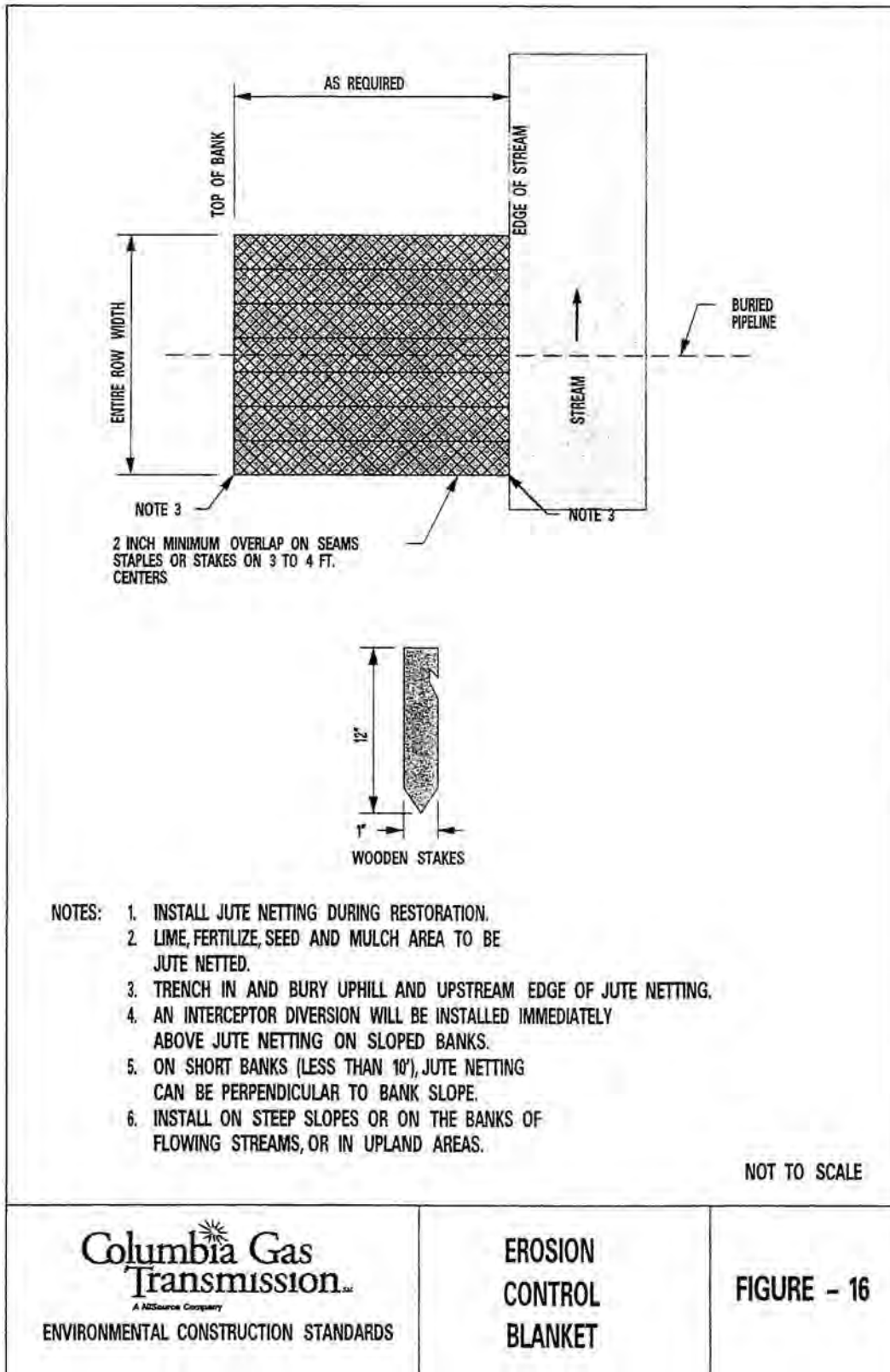

S. Figure 17 – Typical Stream Crossing Intermittent Stream

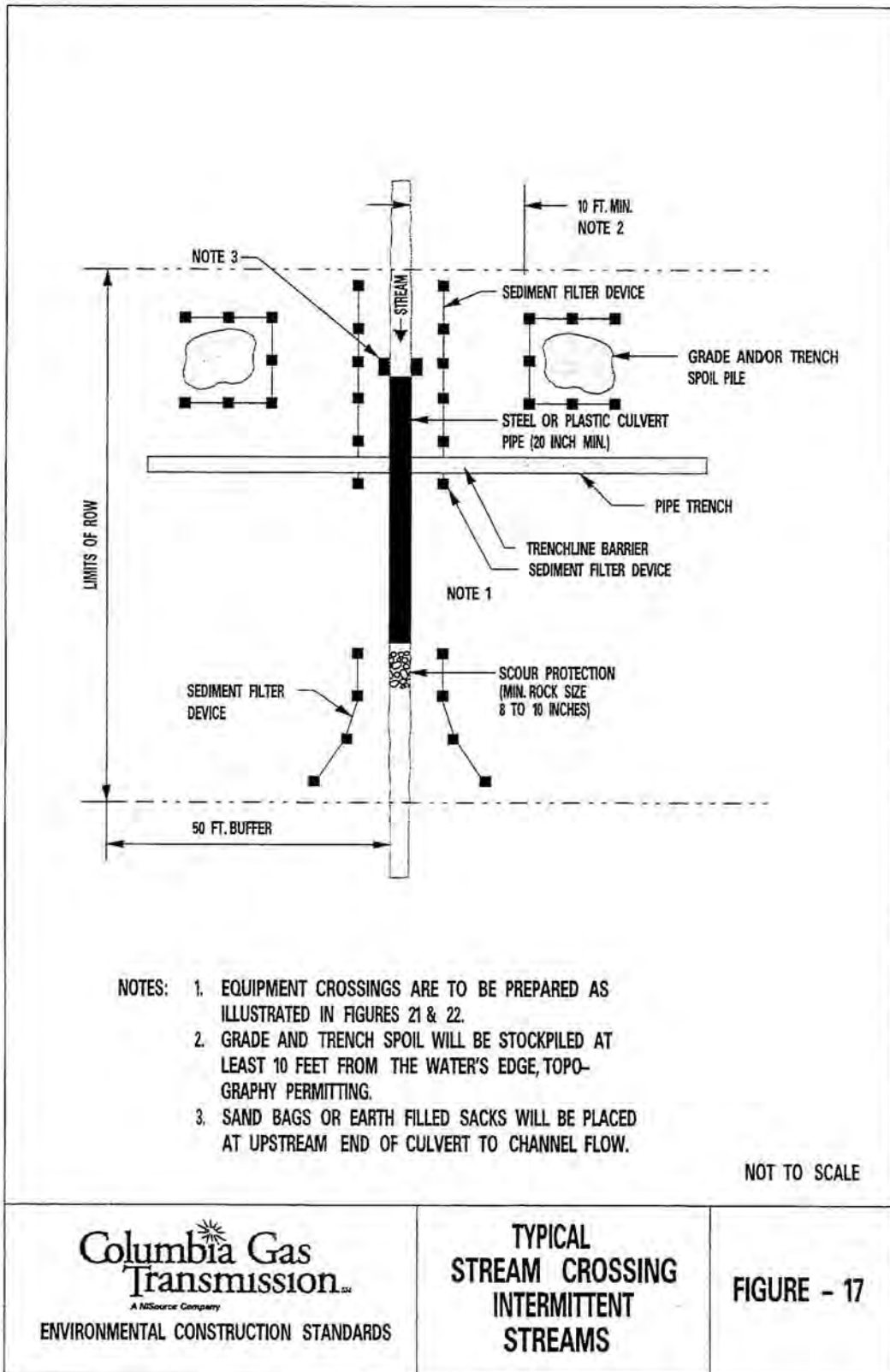

**Columbia Gas Transmission**  
A NISource Company  
**ENVIRONMENTAL CONSTRUCTION STANDARDS**

**TYPICAL  
 STREAM CROSSING  
 INTERMITTENT  
 STREAMS**

**FIGURE - 17**

T. Figure 18 – Typical Stream Crossing Dry-Ditch

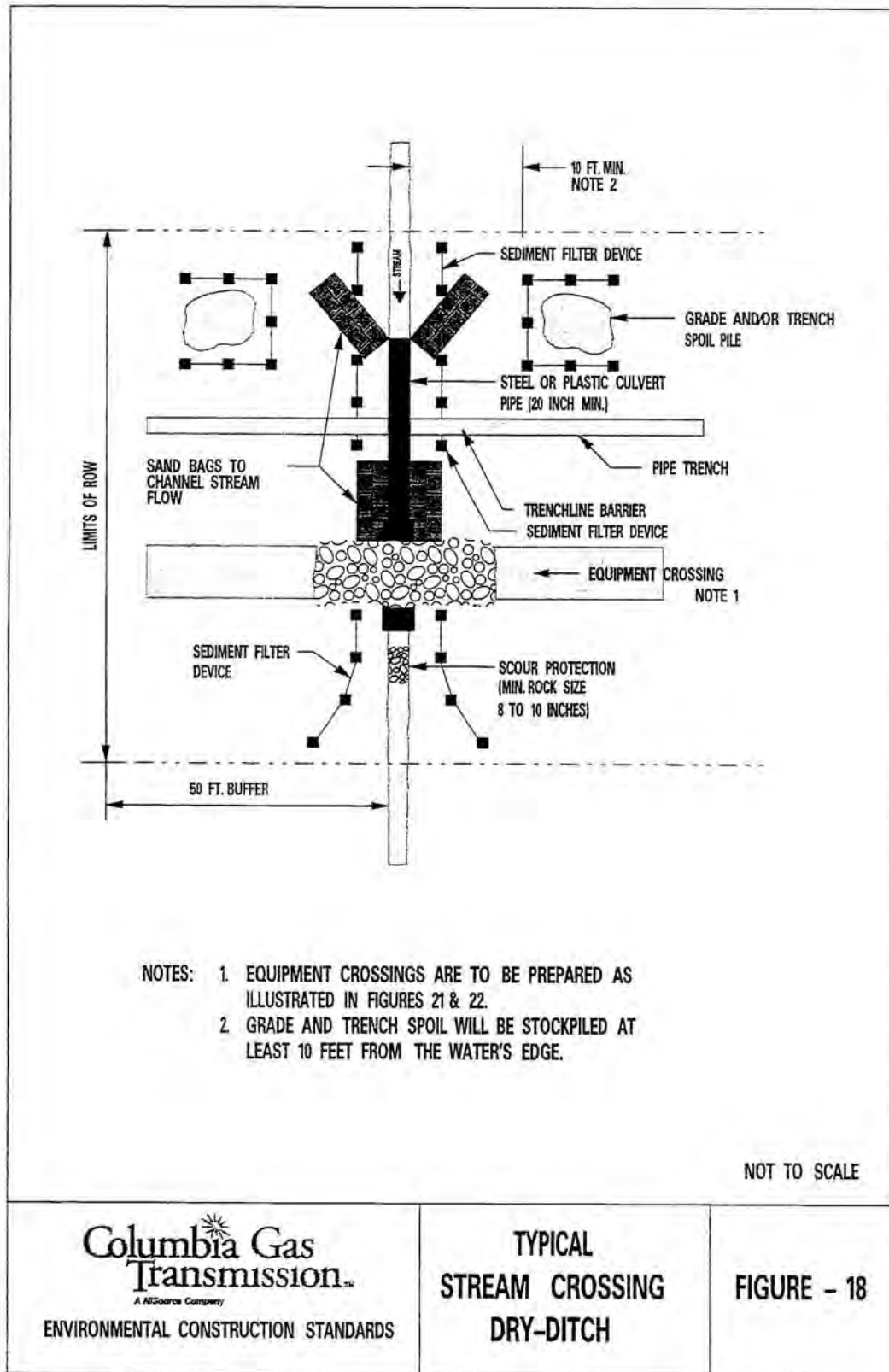

U. Figure 19 – Typical Stream Crossing Dam and Pump

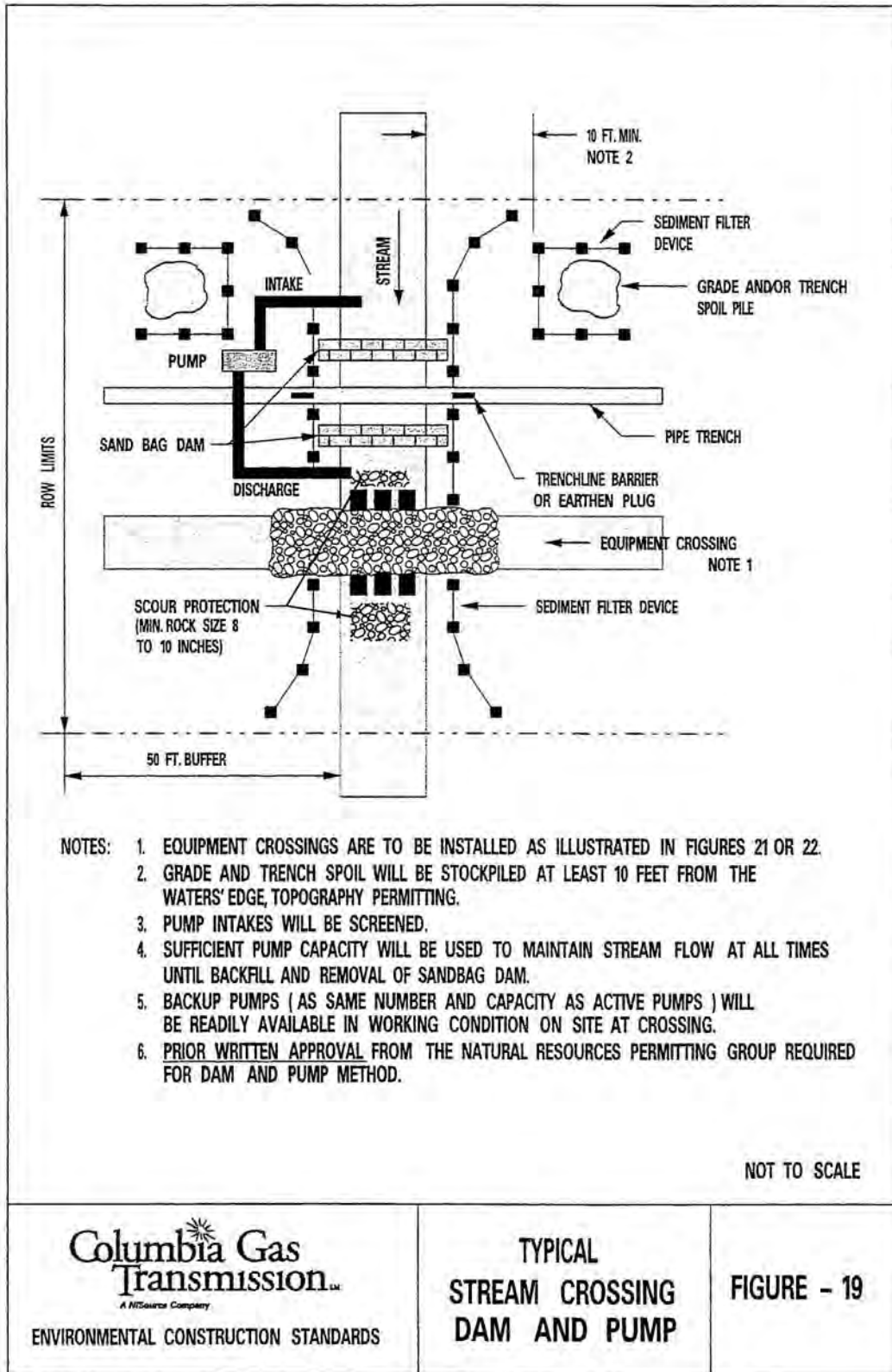

V. Figure 20 – Typical Stream Crossing Wet-Ditch

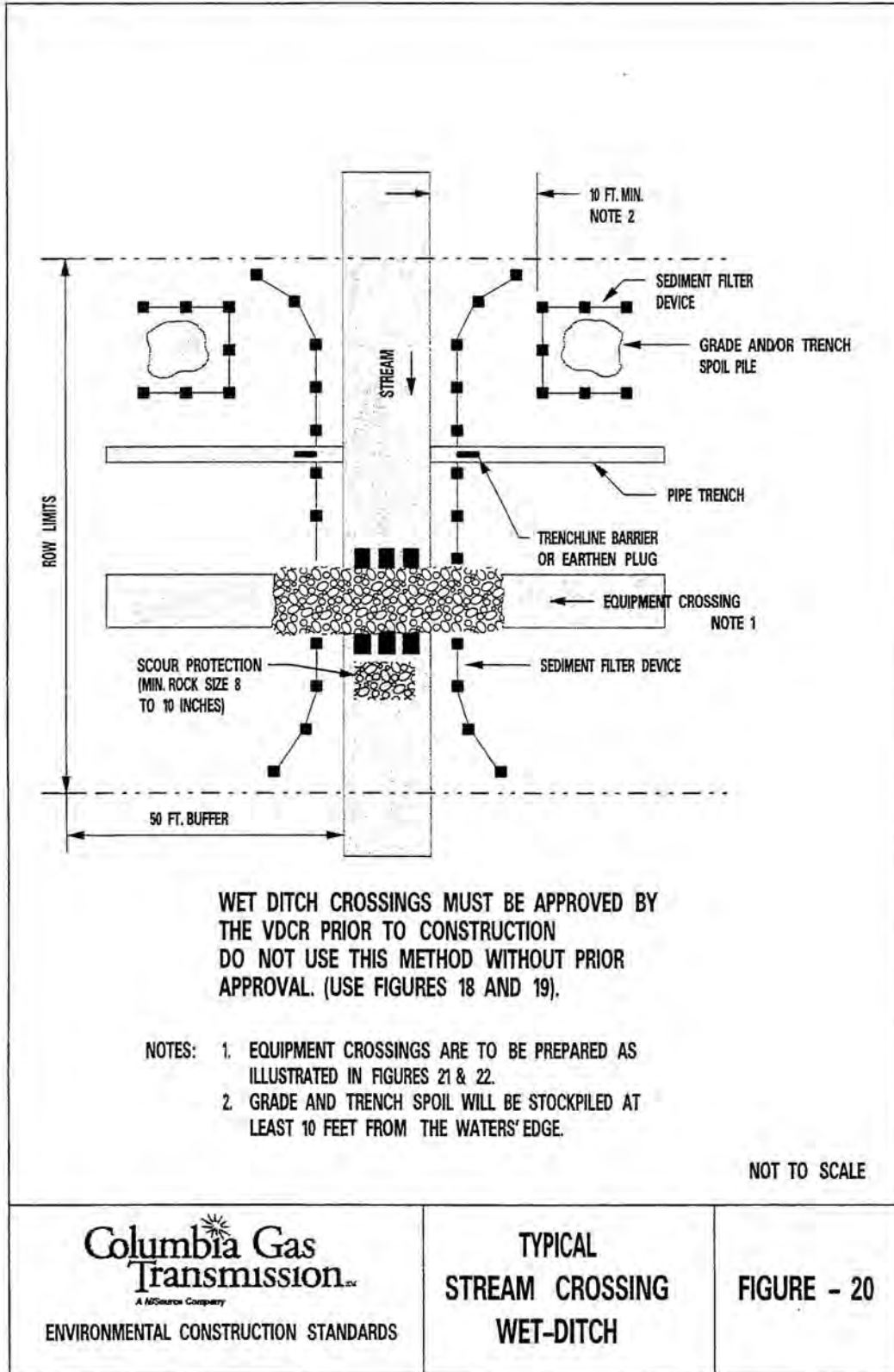



W. Figure 21 – Temporary Equipment Crossing Culvert and Stone

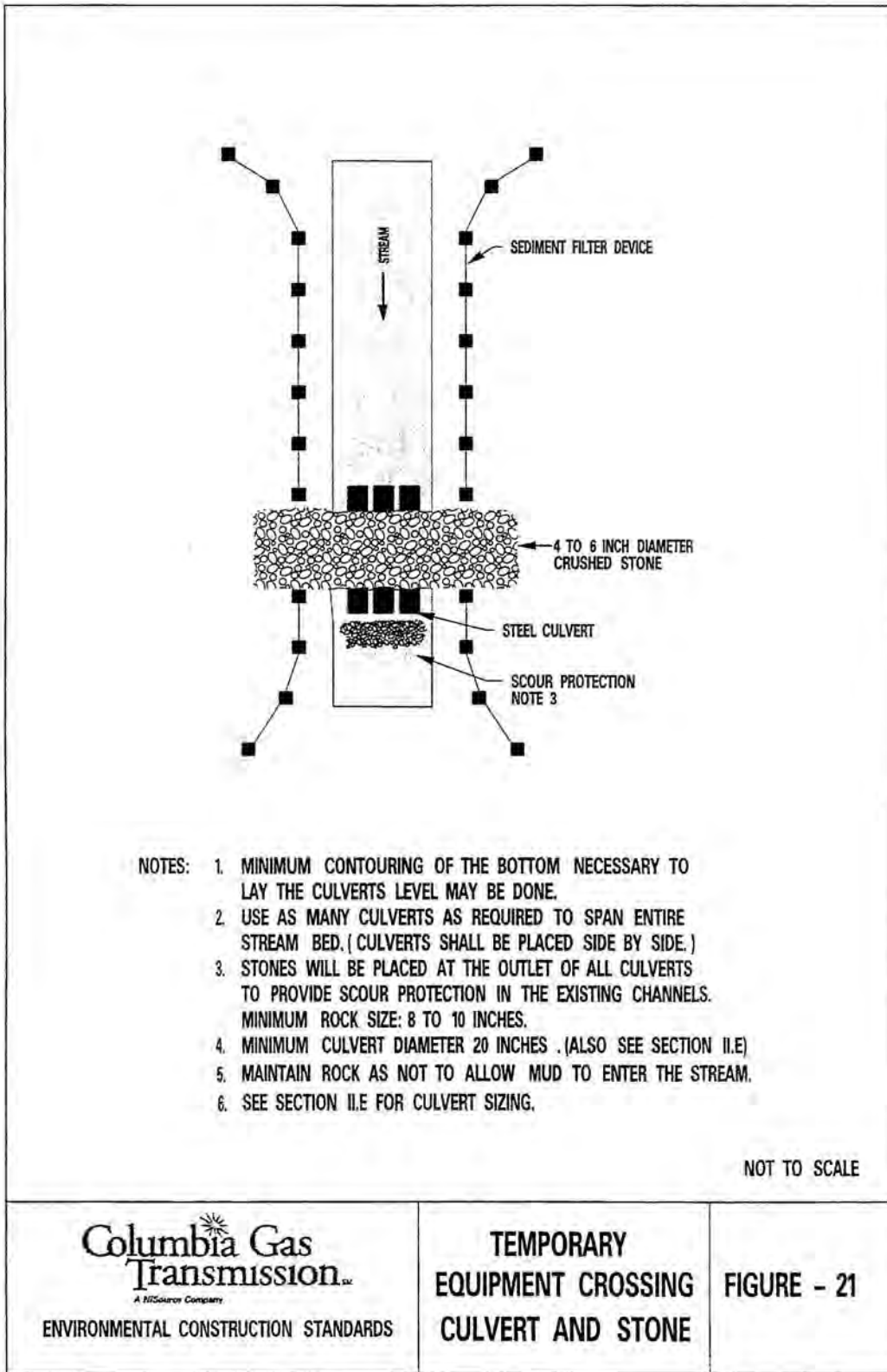

**Columbia Gas**  
**Transmission**  
A NISOURCE Company  
ENVIRONMENTAL CONSTRUCTION STANDARDS

**TEMPORARY  
EQUIPMENT CROSSING  
CULVERT AND STONE**

**FIGURE - 21**

X. Figure 22 – Temporary Equipment Crossing Equipment Pads

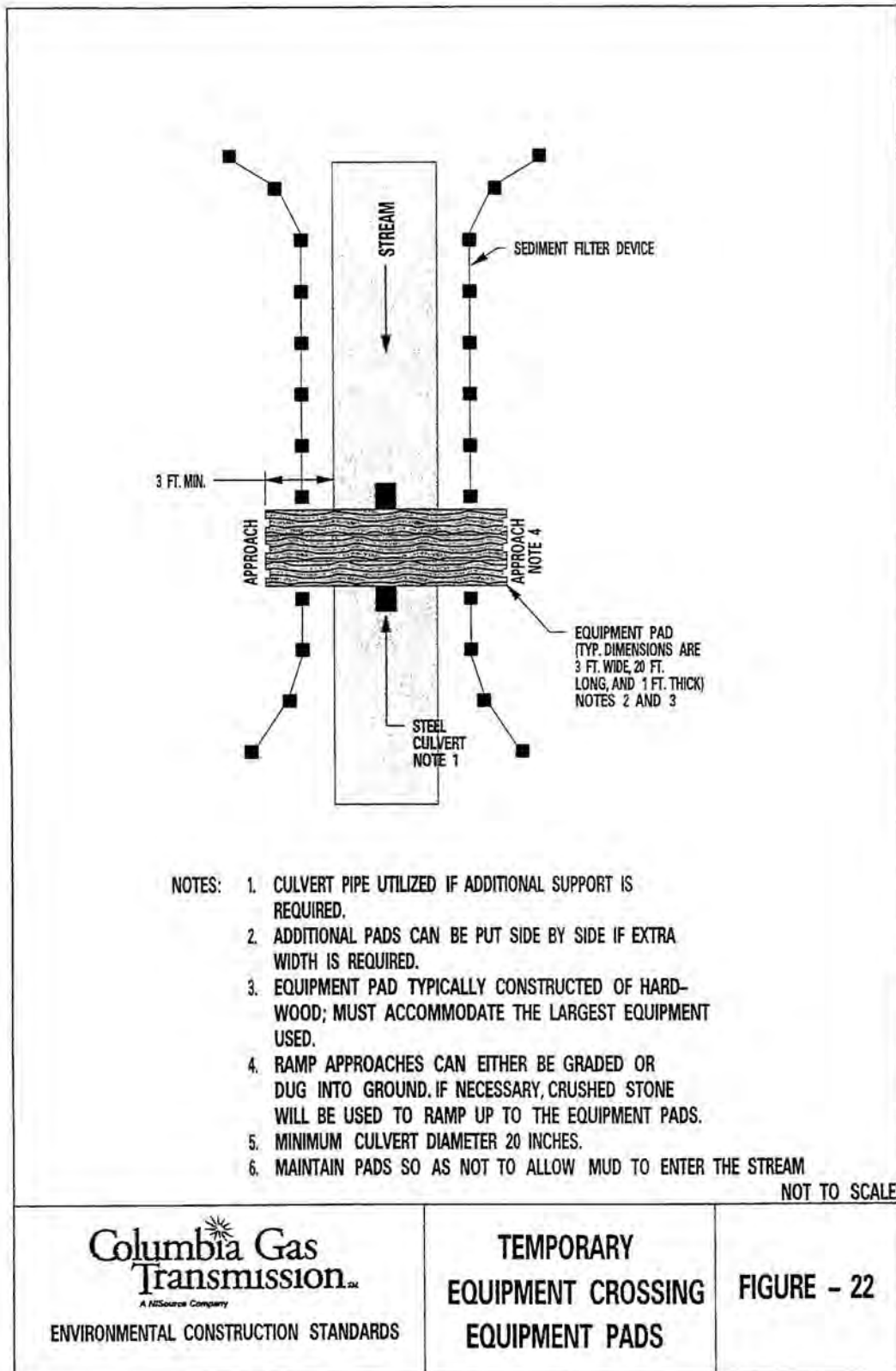

Y. Figure 23 – Typical Wetland Crossing

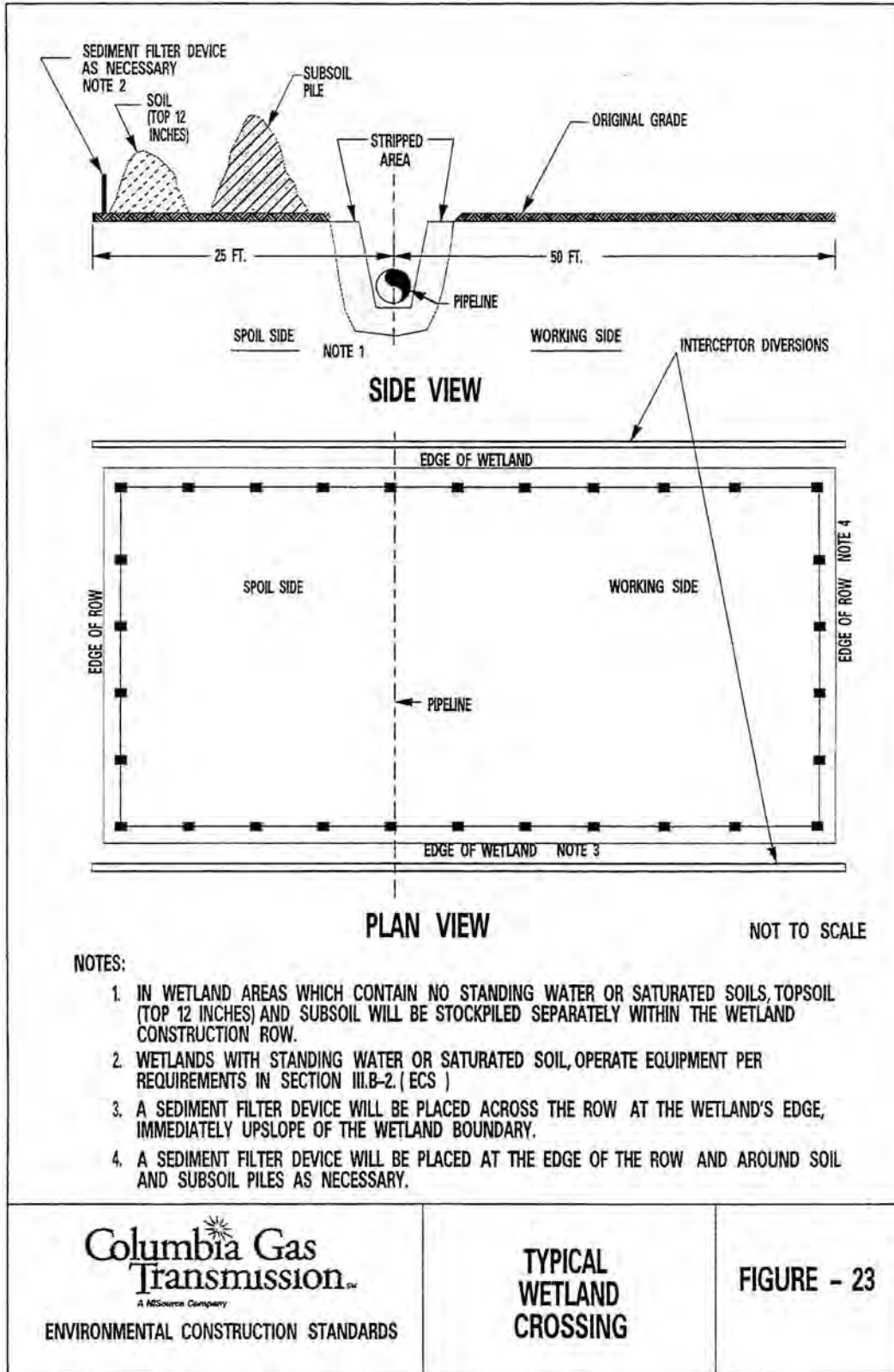

Z. Figure 24 – ROW Maintenance Perennial Streams

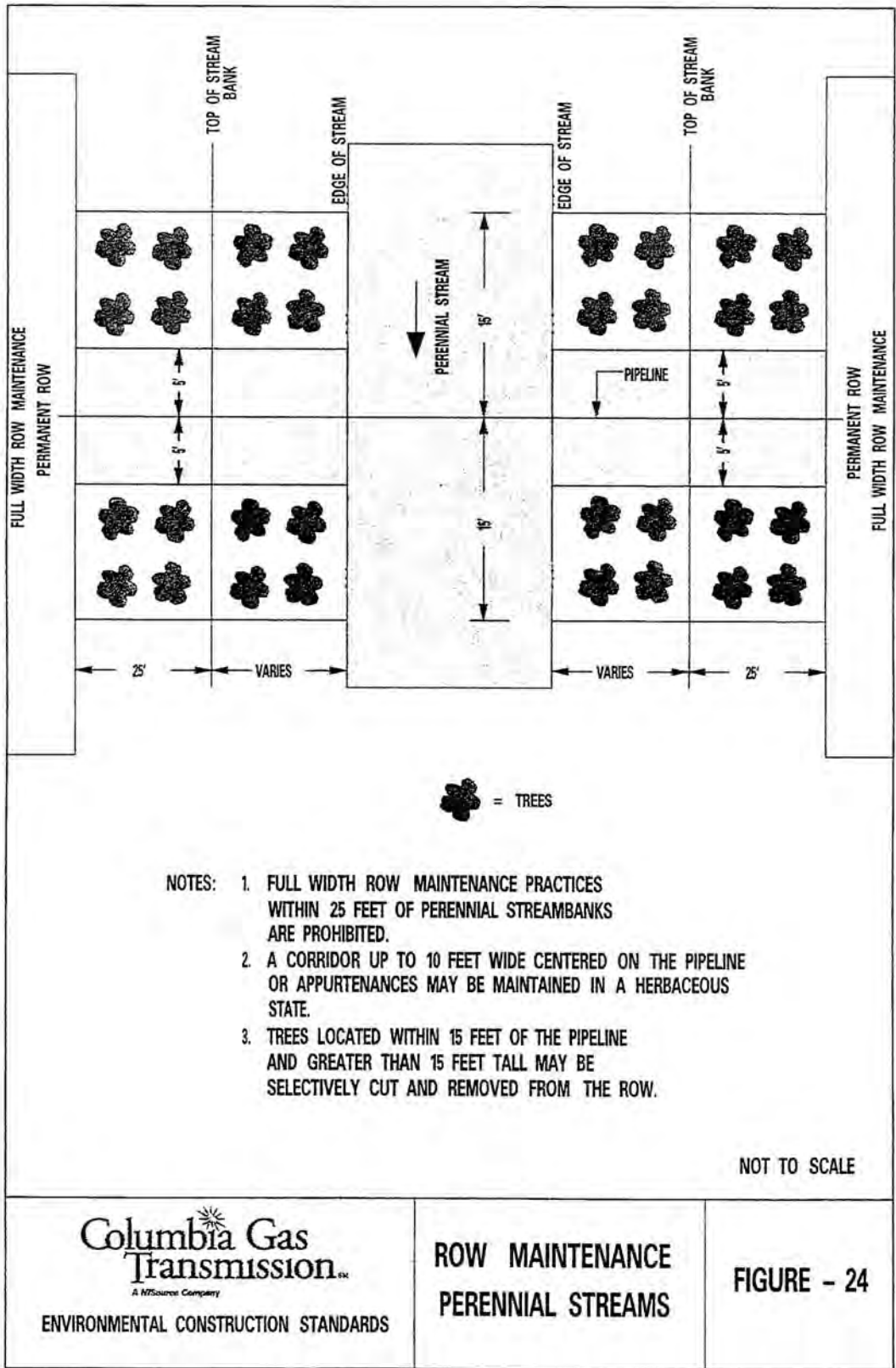



# **ENVIRONMENTAL CONSTRUCTION STANDARDS**

January 2008

---

Columbia Gulf Transmission  
Charleston, West Virginia

## TABLE OF CONTENTS

I.	INTRODUCTION .....	5
II.	UPLAND CONSTRUCTION .....	6
	A.    General.....	6
	B.    Right-of-Way Width .....	6
	C.    Clearing .....	7
	1.    Wood Products .....	7
	2.    Brush .....	7
	3.    Fence Crossings.....	8
	D.    Grading.....	8
	1.    Tree Stump and Rock Removal and Disposal.....	8
	2.    Topsoil Conservation .....	9
	3.    Erosion Control Devices .....	9
	4.    Temporary Road Entrances.....	10
	E.    Access Roads .....	10
	F.    Residential Areas .....	11
	G.    Trenching .....	11
	1.    Trenching Specifications .....	11
	2.    Blasting.....	12
	3.    Temporary Construction Access Over the Trenchline.....	12
	4.    Drainage Tile and Irrigation Facilities .....	12
	H.    Backfilling Specifications .....	13
	I.    Final Grading, Restoration And Stabilization.....	13
	1.    Final Grading .....	13
	2.    Soil Compaction Testing.....	14
	3.    Restoration .....	14
	4.    Temporary Stabilization.....	16
	5.    Restoring Man-Made Structures.....	16
	6.    Off-Road Vehicle (ORV) Control.....	17
	J.    Noise Impact Mitigation .....	17
	K.    Hydrostatic Testing.....	17
III	STREAM AND WETLAND CROSSINGS .....	19
	A.    Stream Crossings.....	19
	1.    General.....	19

2.	Crossing Techniques .....	20
3.	Clearing .....	21
4.	Grading .....	21
5.	Trenching.....	21
6.	Blasting .....	22
7.	Backfilling .....	22
8.	Restoration .....	23
B.	Wetland Crossings .....	24
1.	General.....	24
2.	Crossing Techniques.....	24
3.	Clearing .....	25
4.	Grading.....	25
5.	Trenching.....	26
6.	Blasting.....	26
7.	Backfilling .....	26
8.	Restoration .....	27
IV.	SPILL PREVENTION, CONTAINMENT AND CONTROL .....	27
A.	General.....	27
B.	Spill Cleanup .....	29
V.	MAINTENANCE.....	29
A.	General.....	29
B.	Upland Areas.....	30
C.	Waterbodies, Wetlands, and Environmentally Sensitive Areas.....	31
VI.	ENVIRONMENTAL CONSTRUCTION MANAGEMENT AND INSPECTION.....	32
A.	General.....	32
B.	Environmental Inspector.....	32
C.	Environmental Training .....	33
D.	Contractor’s Environmental Compliance Specialist (Environmental Foreman) ...	33
E.	Environmental Construction Management .....	34
F.	Environmental Variances .....	34
VII.	EMERGENCY CONSTRUCTION.....	34
VIII.	DEFINITION OF TERMS* .....	35
IX.	TABLES.....	38
X.	FIGURES.....	39
A.	Figure 1 – Typical Upland Pipeline Construction Sequence .....	39

B.	Figure 2 – Typical 75 ft. Construction Right-of-Way.....	39
C.	Figure 3 – Typical 50ft. Construction Right-of-Way.....	40
D.	Figure 4 – Temporary Construction Gate.....	41
E.	Figure 5 – Typical Soil Conservation.....	42
F.	Figure 6A - Interceptor Diversions/Slope Breakers .....	43
G.	Figure 6B – Interceptor Diversions.....	45
H.	Figure 7 – Sediment Filter Device Silt Fencing .....	45
I.	Figure 8 – Sediment Filter Device Staked Bales.....	47
J.	Figure 9 – Temporary Road Entrance Rock Pads.....	48
K.	Figure 10 – Temporary Road Entrance Terra-Mats .....	48
L.	Figure 11 – Temporary Road Entrance Board Road.....	50
M.	Figure 12 – Typical Erosion Control Measures at Road Crossings.....	51
N.	Figure 13 – Trenchline Barriers and Breakers .....	52
O.	Figure 14A – Sediment Trap .....	53
P.	Figure 14B – Filter Bag .....	54
Q.	Figure 15 – Field Tile Replacement Methods.....	55
R.	Figure 16 – Erosion Control Blanket .....	55
S.	Figure 17 – Typical Stream Crossing Intermittent Streams.....	57
T.	Figure 18 – Typical Stream Crossing Dry-Ditch .....	58
U.	Figure 19 – Typical Stream Crossing Dam and Pump .....	59
V.	Figure 20 – Typical Stream Crossing Wet-Ditch .....	60
W.	Figure 21 – Temporary Equipment Crossing Culvert and Stone.....	60
X.	Figure 22 – Temporary Equipment Crossing Equipment Pads .....	62
Y.	Figure 23 – Typical Wetland Crossing .....	63
Z.	Figure 24 – ROW Maintenance Perennial Streams .....	64



## I. INTRODUCTION

Columbia is committed to complying with the applicable environmental rules and regulations of federal, state, and local governments. Columbia's goal is to meet these requirements in the pursuit of a cleaner, safer environment for future operations.

Recognizing this goal, it is Columbia's policy that all construction, operation and maintenance activities be conducted in a safe manner that minimizes impacts on stream and wetland ecosystems, wildlife habitat, cultural resources and the human environment. To this end, Columbia has prepared these Environmental Construction Standards (ECS). The ECS provides the minimum requirements to be applied to all construction, operation and maintenance activities.

The general objective of this ECS is to provide Columbia personnel and Columbia's contractors with instructional information, complete with a practical approach to environmental concerns, which can arise before, during and after facility construction. More specific objectives include:

- minimize impacts to environmentally sensitive areas;
- use the minimum land required for safe and efficient construction, operation, and maintenance of the facilities;
- prevent erosion and sedimentation during construction; and
- complete construction in a safe and timely manner.

Words and/or phrases which have special meaning (shown in **bold** at first occurrence in text) and acronyms have been defined in Appendix 1.

The intent of the ECS is to confine project-related disturbance to the identified **construction work areas** and to minimize erosion and enhance revegetation in those areas. Any project-related ground disturbance (including erosion) outside of these areas is subject to compliance with all applicable survey<sup>1</sup> (see superscript note on Page 32) and mitigation requirements.

The ECS is focused primarily on pipeline related construction, operation, and maintenance. However, it can be equally applied to all Columbia facilities, for example, storage facilities including well locations, compressor stations, horizontal directional drill locations and measurement/regulation stations. This ECS shall be used as the base document from which Columbia will build individual project-specific Environmental Management and Construction Plans (EM&CP) as called for in Columbia's Policy and Procedure, Plan 120-10. The EM&CP may include written recommendations from the local soil conservation authorities or land management agencies for both temporary and permanent erosion control and revegetation specifications. Federal, State and local agencies having regulations more stringent than this ECS shall supercede<sup>2</sup> (see superscript note on Page 32)

## II. UPLAND CONSTRUCTION

### A. General

This chapter describes typical upland pipeline construction.

The upland pipeline construction spread operates as a moving assembly line performing specialized procedures in an efficient, planned sequence. Figure 1 presents this typical upland pipeline construction sequence. In addition, special construction crews install and alter fences, bore under roads and railroads, install stream and **wetland** crossings that are not done by conventional upland techniques, and construct valve settings and meter/regulator stations.

While construction work is on going, the construction work area will be kept clean of all rubbish and debris resulting from the work. Non-hazardous materials and waste shall be disposed of in an approved landfill. Hazardous waste shall be disposed of in accordance with Columbia policies (Plan 120.03 and 120.04) and federal, state and local regulations.

### B. Right-of-Way Width

For 14-inch or larger diameter pipelines on new alignments, Columbia typically utilizes a 50-foot wide permanent right-of-way (ROW) and a 25-foot wide temporary construction ROW as illustrated in Figure 2. After the construction work area is restored, the temporary work areas are allowed to revert to its previous uses. The permanent ROW is maintained as Columbia's permanent ROW for the facility. Figure 2 also illustrates the typical pipeline construction work area when paralleling existing facilities.

In addition, there may be instances where extra work areas are needed for topsoil conservation, side hill construction, equipment staging, pipe and material storage, borrow and disposal areas, temporary and permanent access, and related construction activities. Such areas will be identified in the project plans and will undergo all required environmental and cultural resources reviews prior to use. In contrast, pipelines may be constructed through confined areas such as extremely steep and narrow ridges. Alternate construction methods may be required in narrow construction work area situations to safeguard workers, equipment, the pipeline, and the environment.

For 12-inch and smaller diameter pipelines, a 50-foot wide ROW is typically used due to a narrower trench and the use of smaller equipment. The typical 50-foot ROW is illustrated in Figure 3. In addition, there may be areas where extra construction work areas are needed as described above.

For non-pipeline construction activities, such as storage well locations and station projects, the construction work area and permanent ROW may vary and can be dependent on property lease, property owner agreements, and/or local topography. For example, the construction work area for a typical storage well is 200 feet by 200 feet and the permanent ROW is a 300-foot radius around the well.

## C. Clearing

The construction work area is cleared to the width specified in the ROW agreements or EM&CP, whichever is less, during clearing operations, all brush and trees will be felled into the construction work area to prevent off-construction work area damage to trees and structures.

Large or valuable trees may be retained, provided they will not interfere with the construction, operation, or maintenance of the facility.

The clearing crew and related equipment and equipment necessary for installation of equipment crossings will be permitted a single pass through streams prior to equipment crossing installations unless the stream is a **high quality stream** or designated as an **exceptional value water**. Federal, State and local agencies having regulations more stringent than this shall supercede<sup>2</sup> (see superscript note on Page 32).

Should substantial soil disturbance take place during clearing install temporary erosion and sedimentation controls as described in section D-3.

### 1. Wood Products

Wood Products (i.e., sawlogs, pulpwood or cordwood) are the property of the landowner unless otherwise specified. They will not be used for any purpose unless permission is first obtained from the landowner. When the landowner requests salvage of these materials or approves, they will be stockpiled just off the edge of the construction work area, but not within 50 feet of streams, floodplains, or wetlands. Equipment stacking the wood products will not leave the construction work area. Usable timber that measures at least 10 inches in diameter at the butt will be cut into pole lengths or as otherwise negotiated with the landowner. Off-site disposal in other than commercially operated disposal locations is subject to compliance with all applicable survey, landowner approval and mitigation requirements.

### 2. Brush

All cleared brush will be disposed of by one of the following methods:

- Brush may be piled just off the edge of the construction work area but not within 50 feet of streams, floodplains or wetlands. Equipment stacking the brush will not leave the construction work area. Brush piles will be constructed a maximum of 12 feet wide and compacted to approximately 4 feet high, with periodic breaks at a minimum of every 200 feet to permit wildlife travel. The landowner should be consulted to determine acceptable brush pile locations along the construction work area. Landowner approval is required for this method.
- Brush may be burned where permitted by law. The necessary burning permits will be obtained. Fires will be of reasonable size and located and patrolled so that they will not spread off the construction work area.

- The brush may be chipped and given away, buried, or thinly spread (less than 2 inches thick) over the construction work area or blown off the construction work area (per landowner agreement) except in **agricultural lands** or within 50 feet of streams, floodplains, or wetlands. Chipping will be limited to those areas where agreed to with the landowner. During **restoration**, soil will be augmented by the addition of 12 to 15 pounds of nitrogen per ton of chips to aid revegetation.\*
- Brush may be hauled off-site. Off-site disposal in other than commercially operated disposal locations is subject to compliance with all applicable survey, landowner approval and mitigation requirements.

\*One ton of chips spread 1 inch thick cover approximately ¼ acre.

### 3. Fence Crossings

Where it is necessary to remove fences, adequate temporary fences or gates as illustrated in Figure 4 will be installed **immediately** or in accordance with landowner agreement. Such temporary fences or gates will be kept closed, except when necessary for construction purposes per landowner agreement. Once construction is completed, permanent fence repairs will be completed. All fences that have been cut or removed will be permanently repaired during restoration to match the original type of the fence as much as possible. Where there is any doubt as to the usability of old fence material, new material will be used in making repairs. Fence repairs will be subject to the approval of the landowner.

## D. Grading

Grading is necessary to provide a smooth and even surface for safe and efficient operation of construction equipment. Grading will be the minimum amount necessary and includes prompt installation of erosion control devices such as interceptor diversions, **sediment filter devices**, and equipment crossings at streams to minimize soil loss and subsequent sedimentation.

### 1. Tree Stump and Rock Removal and Disposal

Tree stumps and large rocks will be cut, graded or removed as necessary to permit construction and to provide adequate clearance for mechanical equipment and other vehicles. Tree stumps that are adjacent to roads will be cut close to the ground or removed.

Stumps and large rocks will be disposed of in the following manner pending landowner approval.

- buried within the construction work area except in agricultural, residential, or wetland areas;
- windrowed just off the edge of the construction work area with landowners' permission. windrows will be a maximum of 12 feet wide with periodic breaks a minimum of 200 feet apart;

- hauled from the site and disposed of in an approved landfill or other suitable area.

Off-site disposal in other than commercially operated disposal locations is subject to compliance with all applicable survey, landowner approval and mitigation requirements.

## 2. Topsoil Conservation

Unless the landowner or land management agency specifically approves otherwise, prevent the mixing of topsoil with subsoil by stripping topsoil from either the full work area or from the trench and subsoil storage area (ditch plus soil side method) in:

- a. actively cultivated or rotated croplands and pastures;
- b. residential areas;
- c. hayfields; and
- d. other areas at the landowner's or land managing agency's request.

In deep soils (more than 12 inches of topsoil), segregate at least 12 inches of topsoil. In soils with less than 12 inches of topsoil make every effort to segregate the entire topsoil layer. Segregated topsoil may not be used for padding the pipe. Figure 5 illustrates topsoil conservation techniques.

The topsoil will be stockpiled separately from all subsoil and will be replaced last during backfilling and **final grading**. Where topsoil is stripped from the entire construction ROW, an additional 25-foot wide temporary work area may be used for topsoil storage with landowners' permission and appropriate environmental approvals. The **Inspector** will determine if additional erosion control devices are needed in topsoil storage areas.

In residential areas, topsoil replacement (i.e., importation of topsoil) is an acceptable alternative to topsoil segregation.

## 3. Erosion Control Devices

Temporary erosion controls will be installed immediately after or during the initial disturbance of soil. The most effective and versatile erosion control devices are interceptor diversions (temporary slope breakers) and sediment filter devices as illustrated and described in Figures 6A, 6B, 7, and 8. Temporary diversions will be maintained during the construction phase until final diversions are installed. Where required grading has significantly reduced the slope, the Inspector may require fewer temporary diversions consistent with the table on Figure 6.

At a minimum, install and maintain temporary sediment barriers (silt fence, staked hay or straw bales, compacted earth, sand bags, or other appropriate materials) across the entire construction right-of-way at the base of slopes greater than 5 percent where the base of the slope is less than 50 feet from a waterbody, wetland, or road crossing until revegetation is successful. Leave adequate room between the base of

the slope and the sediment barrier to accommodate ponding of water and sediment disposition.

All temporary erosion control devices, including roadside ditches, will be inspected near the end of each work day or after each storm (rain) event of 1/2 inch or greater, to ensure proper functioning. Any devices damaged beyond functioning will be repaired **promptly**.

#### **4. Temporary Road Entrances**

Temporary road entrances as illustrated in Figures 9, 10, and 11 will be installed during grading where the construction work area crosses public roads when needed to maintain safe conditions and to prevent tracking soil and mud onto public roads. These installations are designed to remove mud from vehicle tires and tracks before accessing the road. In addition, public roads will be swept, shoveled or scraped as necessary to keep the road surface safe. If the public road is gravel, the temporary entrance is not required to be graveled. Typical erosion control measures at road crossings are illustrated in Figure 12. If no access is required onto the roadway the installation of a construction entrance is not required, however, safety fencing should be installed across the ROW and signs designating "no entrance" can be erected to avoid any unintentional entrances.

#### **E. Access Roads**

Typically, Columbia requires access roads to the construction and staging areas. New access roads will be built only if existing access is inadequate. The access roads will be a maximum 25-foot wide with additional width in tight turns and at intersections with public roads. The roads will either be temporary (used for access during construction only) or permanent (used during and after construction for operation and maintenance of the facilities). All public roads are available for use as access roads without further environmental review. However, all private access roads intended for use are subject to environmental reviews. Safe and accessible conditions will be maintained at all roadway crossings and access points during construction and restoration.

Access road gradient will be as flat as local topography will practically allow. By breaking or changing grade frequently, fewer erosion problems will be encountered than on long, straight, continuous gradients. Interceptor diversions and/or other erosion and sediment control devices will be installed as needed.

At temporary road entrances, geotextile fabric will be used as illustrated in Figures 9, 10 and 11. The roadbed should be cleared of small stubs because these tend to puncture the fabric, thereby allowing fine particles to mix with the gravel. Geotextile fabric not required at existing, graveled access road entrances, if gravel is to be left after construction landowner approval is required.

Roads will cross streams and wetlands as close as possible to right angles. Road gradients approaching these crossings will be flattened to decrease runoff velocity. Runoff will be dispersed just prior to the crossing by means of an interceptor diversion with a sediment filter device at the outlet. Where conditions permit, new roads will be located at least 25 feet from any stream or wetland

except at crossing locations. Culverts will be sized and placed to permit water flow under the access road.

After construction, temporary access roads (including any additional width used for construction) will be graded and left intact for the landowner's benefit, or removed and the area restored using the same specifications as applied to the construction work area.

## **F. Residential Areas**

The following mitigation measures will be implemented for all residences within 50 feet of the construction work area:

- mature trees and landscaping will not be removed from within the edge of the construction work area unless necessary for safe operation of construction equipment;
- immediately after backfilling the trench, all lawn and landscaping will be restored to final restoration, or temporary restoration pending weather and soil conditions;
- while the trench is open, the edge of the construction work area adjacent to the residence will be safety fenced for a distance of 100 feet on either side of the residence to ensure that equipment, materials and spoil remain within the construction work area;
- a minimum of 25 feet will be maintained between the residence and construction work area for a distance of 100 feet on either side of the residence. If the facility must be within 25 feet of a residence, it must be installed such that the trench does not remain open overnight.

## **G. Trenching**

### **1. Trenching Specifications**

Typically, the trench will not remain open for more than 30 days in any area unless authorized by the Inspector (additional restrictions for stream and wetland areas are provided in Section III).

- As the trench is completed, trenchline breakers as illustrated in Figure 13 will be installed promptly at every second temporary interceptor diversion at a minimum. Topsoil will not be used to construct the breakers. The breakers reduce water velocity and erosion of the trench bottom. The breakers will be maintained promptly.
- Sediment filter devices will be installed around spoil storage areas before digging bore pits, stream crossings, and as necessary wetland crossings.
- If it is necessary to pump water from the trench or bore pits, the water will be pumped into a heavily vegetated upland area where the water will filter back into the ground, a sediment trap as illustrated in Figure 14A, a sediment filter bag as illustrated in Figure 14B, and/or through

a sediment filter device such as a series of terra tubes, sediment logs or flocculent logs least 10 feet from any stream or wetland in order to minimize erosion and subsequent sedimentation of streams or wetlands. Water impounded in the trench will not be released directly or by overland flow into any **waterbody** or wetland. Dewater the trench in a manner that does not cause erosion and does not result in heavily silt laden water flowing into a waterbody or wetland.

When the trench must remain open for a greater length of time, appropriate erosion controls and safety measures will be employed as directed by the Inspector.

## **2. Blasting**

All drilling and blasting will be done in a cautious manner, and suitable precautions will be taken to avoid injury or damage to persons, livestock, or other property.

If blasting is necessary within 150 feet of residential or commercial buildings, An independent contractor will be hired to perform pre- and post-blast structural inspections and, if necessary, seismographic monitoring.

In those instances where blasting has the potential to affect water quantity/quality from domestic or agricultural wells or springs in the proximity of the construction work area, Columbia will conduct pre- and post-blasting (within two months of construction work restoration) testing of water wells within an appropriate distance (typically 150 feet) of the pipeline with landowner permission. These tests may include a pump inspection, flow rate, and bacteriological cultures. If a water well is damaged as a result of Columbia's activities, Columbia will provide a temporary source of water and compensate the owner.

## **3. Temporary Construction Access Over the Trenchline**

Where access across the trenchline is required, temporary facilities such as trench plugs and fences, wooden mats or steel plates will be constructed or installed to permit safe crossing of livestock, vehicles, equipment, and persons from one side of the trench to the other.

## **4. Drainage Tile and Irrigation Facilities**

Attempt to locate existing drain tiles and irrigation systems. Columbia personnel will contact landowners and/or the local National Resource Conservation Service (NRCS) to determine the locations of future drain tiles that are likely to be installed within 3 years of the authorized construction, if planned, the pipeline will be installed at a sufficient depth to accommodate the drainage tile. For adjacent pipeline loops in agricultural areas, install the new pipeline with at least the same depth of cover as the existing pipeline(s) and within US Department of Transportation (DOT) specifications. Mark locations of drain tiles damaged during construction.



Engage qualified drain tile specialists, as needed to conduct or monitor repairs to drain tile systems affected by construction. Use drain tile specialists from the project area, if available. Drainage tile removed, cut, broke, or otherwise damaged during construction will be repaired or replaced as illustrated in Figure 15. Temporary measures approved by the Inspector will be taken to provide suitable drainage until permanent repairs are made. Repair damaged drain tiles to their original or better condition. Do not use filter-covered drain tiles unless the local soil conservation authorities and landowner agrees.

Water flow will be maintained in crop irrigation systems unless shutoff is coordinated with affected parties.

#### **H. Backfilling Specifications**

Backfilling will follow pipe lowering as closely as practical. Topsoil will not be used to pad the pipe. Soil that has been excavated during construction and not used for backfill will be evenly spread over the cleared construction work area or removed from the site and properly disposed. All waste materials such as cans, stumps, coating and wrap, rubbish, waste, or other refuse will not be placed in the trench.

Trenchline barriers as illustrated in Figure 13 will be placed in the trench prior to backfilling to prevent water movement and subsequent erosion. An engineer or similarly qualified professional shall determine the need for and spacing of trenchline barriers. Otherwise, trenchline barriers shall be installed at the spacing illustrated in Figure 13 and up-slope of any permanent interceptor diversions.

Excess rock, including blast rock, may be used to backfill the trench to the top of the existing bedrock profile. Care should be taken to not damage the pipeline.

#### **I. Final Grading, Restoration And Stabilization**

After construction activities, all disturbed areas will be stabilized with either, (1) final grading and restoration; or (2) **temporary stabilization** measures in order to prevent erosion and sedimentation until final grading and restoration can be completed.

##### **1. Final Grading**

Final grading will be completed within 20 calendar days of backfilling (10 days in residential areas), weather and soil conditions permitting. Should unsuitable soil conditions persist, or be expected to persist, for more than 20 calendar days (10 days in residential areas), the Inspector will record the conditions and require the installation of temporary stabilization measures, and final grading and restoration will be delayed until conditions allow. In no case shall final grading be delayed beyond the end of the next recommended seeding season.

If final grade can be established, but conditions are not ideal for permanent seeding, the Inspector will specify application of temporary stabilization measures (including temporary seeding), and may also

consider concurrent application of final seed mix and mulch as provided in Table 2a or per the local conservation authority.

Grade the construction right-of-way to restore pre-construction contours.

During final grading, soil over the trench may be mound to allow for future settling. Where fill in the trench or major depressions have settled below ground level, additional fill will be added as needed, and the area brought to final grade. The Inspector may approve a temporary travel lane in the construction work area where needed to facilitate the remainder of construction and/or restoration. This travel lane must be restored when access through the area is no longer required.

Conserved topsoil will be returned during final grading.

Excess rock will be removed from at least the top 12 inches of soil to the extent practicable in all actively cultivated or rotated agricultural land, hayfields, pastures, residential areas, and other areas at the landowner's request. The size, density and distribution of rock on the construction work area should be similar to adjacent areas not disturbed by construction. Diligent efforts will be made to remove rocks greater than 4 inches if, off-construction work areas do not contain rocks greater than 4 inches. The landowner may approve other rock size provisions in writing.

Final erosion control devices including interceptor diversion/slope breakers will be installed during final grading. Sediment filter devices needed to protect off-construction work area resources will be installed or rebuilt promptly after final grading. Final interceptor diversions will not be installed in agricultural or pasture land without landowner's consent.

## **2. Soil Compaction Testing**

Test topsoil and subsoil for compaction at regular intervals in agricultural and residential areas disturbed by construction activities. Conduct tests on the same soil type under similar moisture conditions in undisturbed areas to identify approximate preconstruction conditions. Use U.S. Army Corps of Engineers-style cone penetrometers or other appropriate devices to conduct tests.

Plow severely compacted agricultural areas with a paraplow or other deep tillage implement. In areas where topsoil has been segregated, plow the subsoil before replacing the segregated topsoil. Alternatively, make arrangements with the landowner to plant and plow under a "green manure" crop, such as alfalfa, to decrease soil bulk density and improve soil structure. If subsequent construction and cleanup activities result in further compaction, conduct additional tilling.

Perform appropriate soil compaction mitigation in severely compacted residential areas.

## **3. Restoration**

Restoration as defined in Appendix 1, will begin within 6 days of final grading, weather and soil conditions permitting. Fertilizer and lime will be

disked into the soil (except rocky soils) to a depth of 3 to 4 inches to prepare a seedbed. In rocky soils, fertilizer and lime may be incorporated into the soil with tracked equipment. Seeding and mulching the construction work area will promptly follow seedbed preparation. Ensure that mulch is adequately anchored to minimize loss due to wind and water. Mulch tackifiers used in accordance with the manufacturers recommendations may be used as an alternative. Do not use liquid mulch binders within 100 feet of wetlands or waterbodies.

The typical application rates for lime, fertilizer, seed and mulch are listed in Table 2a. They will be used unless the ROW agreement, permit or local NRCS provides project-specific recommendations. If Tall Fescue is used, plant endophyte free certified seed.

If hydroseeding is utilized, lime and fertilizer applications should be equivalent to table 2a unless ROW agreement, permit or the local NRCS provides project specific recommendations. Hay or straw mulch shall be applied in accordance with table 2a over hydroseeding. Hydromulch can be used in conjunction with (for texture purposes) but not substituted for hay or straw mulch. **Scarify** the seedbed to facilitate lodging and germination of seed.

Uniformly apply and cover seed in accordance with the written recommendations of the local soil conservation authorities or land management agencies.

Base seeding rates on Pure Live Seed. Use seed within 12 months of seed testing. Treat legume seed with an inoculant specific to the species using the manufacturer's recommended rate of inoculant appropriate for the seeding method. If the above recommendations are not available for conventional seeding, use 4 times the manufactures recommended rate of inoculate. For hydroseeding, use 10 times the recommended rate of inoculant.

In the absence of recommendations from the local conservation authority, a seed drill equipped with a cultipacker is preferred for application, but broadcast or hydroseeding can be used at double the recommended seeding rates. Where seed is broadcast, firm the seedbed with a cultipacker, roller or other suitable means after seeding. In rocky soils or where site conditions may limit the effectiveness of this equipment, other alternatives may be approved by the environmental inspector.

Restoration will not be performed in agricultural lands from the beginning of the spring thaw through May 15 unless requested by the landowner. Restoration will be coordinated with the landowner's planting schedule. Grazing deferment plans will be developed with willing landowners, grazing permittees, and land management agencies as appropriate to minimize grazing disturbance of revegetation efforts.

Permanent seeding, liming, and fertilizing may be performed by the landowner. The Inspector will ensure that the restoration is satisfactory and consistent with the regulatory requirements. Restore all turf, ornamental shrubs, and specialized landscaping in accordance with the landowner's request, or compensate the landowner.

Restoration work must be performed by personnel familiar with local horticultural and turf establishment practices.

Jute netting as illustrated in Figure 16 or equivalent approved by the Inspector may be used on **steep slopes** to help stabilize the construction work area.

Restoration shall be considered successful if the right-of-way surface condition is similar to adjacent undisturbed lands, construction debris is removed (unless requested otherwise by the landowner or land managing agency), revegetation is successful, and proper drainage has been restored.

#### **4. Temporary Stabilization**

When the Inspector determines that temporary stabilization measures are required, they will be completed as soon as possible. The seeding and mulching rates are provided in Table 2b. Consideration will be given to the following when determining if temporary stabilization measures are to be implemented:

- if final grading and installation of permanent interceptor diversions or slope breakers will not be completed in an area within 20 days after the trench in that area is backfilled (10 days in residential areas);
- anticipated weather conditions; and
- resources on and off the construction work area to be protected.
- construction or restoration activity is interrupted for extended periods.

If temporary stabilization measures are utilized, final grading and/or restoration must commence once weather and soil conditions permit.

Apply mulch in accordance with the specifications outlined in this section however, during temporary restoration; increase mulch application on all slopes (8 percent or more) within 100 feet of waterbodies and wetlands to a rate of 6,000 lbs/acre (3 tons).

#### **5. Restoring Man-Made Structures**

All existing man-made installations that are disturbed or damaged during construction along new ROW will be repaired or replaced and left in equivalent or better condition than they were found prior to construction, unless alternative arrangements with landowners dictate otherwise.

Man-made installations on existing ROW that are disturbed or damaged during construction will be addressed consistent with Columbia's encroachment policy.

## 6. Off-Road Vehicle (ORV) Control

Columbia will discuss with each landowner and park manager along new ROW (not adjacent to existing ROW) in forest lands the need for ORV control. If requested, one or more of the following ORV control measures will be installed:

- Plant conifers (pine trees) across the construction work area. The spacing of trees and length of construction work area planted should provide for adequate facility maintenance, but should be sufficient to limit access and to screen the ROW from view. Trees will not be planted directly over the pipeline.
- Install a slash and timber barrier, a pipe barrier, or a line of boulders across the construction work area to restrict vehicle access.
- Install a locking gate with fencing extending a reasonable distance to prevent bypass.
- Install “No Trespass” signs.

## J. Noise Impact Mitigation

Construction equipment will be properly muffled and maintained to avoid producing excessive noise near **noise sensitive areas**.

Efforts will be made to control dust at sensitive areas such as residential areas and road crossings. Water trucks will be used at a minimum to dampen the work area if dust becomes a problem.

## K. Hydrostatic Testing

Typically, Columbia verifies a facility’s integrity by hydrostatic testing. Water will be drawn from local sources (streams, ponds, public water supplies) in a manner that will minimize impacts to the environment and other existing users, while maintaining adequate stream flow. Water from state designed *high quality streams* or *exceptional value waters*, waterbodies which provide habitat for federally listed threatened or endangered species, or streams utilized as public water supplies will not be used unless other water sources are not readily available and the appropriate federal, state or local agency permits its use.

Intake hoses will be screened.

Locate hydrostatic test manifolds outside wetlands and riparian areas to the maximum extent practicable.

All required federal, state and local approvals for the withdrawal and/or discharge of hydrostatic test water will be obtained prior to such activities.

Jurisdictional agencies will be notified of the intent to withdraw water from streams. Notify appropriate state agencies of intent to use specific sources at least 48 hours before testing activities unless they waive this requirement in writing.

Maintain adequate flow rates to protect aquatic life and provide water for downstream withdrawals by existing users.

Comply with all approval/permit conditions which may include notifying the appropriate state agency of withdraw/discharge and collection of samples in accordance with permit conditions where required.

All welds will be radiographically inspected or hydrostatically tested before pipe installation under waterbodies or wetlands.

The discharge of the hydrostatic test water will be performed in a manner that minimizes erosion. The energy of the released test water will be dissipated by discharging the water:

- into a well-vegetated upland area;
- into a tank(s)
- into a body of water (with all required permits); or
- through sediment filter devices or a sediment trap to filter out various particulate matter or allow it to infiltrate through the soil.

If necessary, regulate the water discharge rate, use energy dissipation device(s); and/or install sediment barriers to prevent erosion, streambed scour, suspension of sediments, or excessive streamflow. During the discharge, the Inspector must ensure that erosion and sedimentation are properly controlled.

Do not discharge into waters from state designated exceptional value waters, waterbodies which provide habitat for federally listed threatened or endangered species, or streams utilized as public water supplies unless the appropriate federal, state or local agency grants permission.

Methanol may be injected, after discharging the water, to dry the pipe. Excess methanol will be retrieved from the facility and used during subsequent operation of Columbia's facilities.

This guidance is for hydrostatic testing of new pipe. Permitting requirements associated with hydrostatic testing of used pipe can be extensive. Contact the Construction Permitting Specialist prior to testing any used pipe.

### III STREAM AND WETLAND CROSSINGS

#### A. Stream Crossings

##### 1. General

The main objective of any waterbody crossing is to construct the pipeline in a manner, which minimizes erosion and subsequent sedimentation into the waterbody. Crossings will be constructed as close as possible to right angles with the waterbody channel. Adequate downstream flow rates will be maintained at all times to protect aquatic life and prevent the interruption of existing downstream uses. Each waterbody crossing will be treated as a separate construction entity, such that trenching, pipe installation, backfilling and temporary stabilization or final restoration are completed in the minimum number of consecutive calendar days possible.

Whenever a time limit is imposed on a crossing procedure, that time limit is only applicable to trenching (except blasting), lowering in, and backfilling. Clearing, grading and equipment crossing installation and removal activities are not included as part of the separate construction entity. Construction equipment will not be allowed in the water except as provided in this Section.

Unless expressly permitted or further restricted by the appropriate state agency in writing on a site-specific basis, crossings must be constructed during the following time windows:

- Coldwater Fisheries - June 1 through September 30
- Coolwater and Warmwater Fisheries - June 1 through November 30

Columbia will notify in writing authorities responsible for potable water supplies at least one week, or as required by state or local regulation, prior to any waterbody crossing.

When water levels are temporarily high, the Inspector will direct that starting any waterbody crossing be postponed until water levels subside.

Any extra work areas will be located at least 50 feet away from the water's edge, except where the adjacent upland consists of actively cultivated or rotated cropland or other disturbed land. Where topographic conditions do not permit a fifty-foot setback, contact the Natural Resources Permitting group for approval. All extra work areas must be located at least 10 feet from the water's edge and limited to the size needed to construct the crossing. Pipe assembly for the waterbody crossing is usually performed in the extra work areas prior to or concurrently with trenching.

Standards relating to spill prevention at waterbodies are contained in Section IV., "Spill Prevention".

If the facility parallels a waterbody, attempt to maintain at least 15 feet of undisturbed vegetation between the waterbody and the right-of-way except at the crossing location. Where waterbodies are adjacent to the construction right-of-way, install sediment barriers along the edge of the construction right-of-way as necessary to contain spoil and sediment within the right-of-way.

Waterbody buffers (extra work area setbacks, refueling restrictions, etc.) must be clearly marked in the field with signs and/or highly visible flagging until construction related ground disturbing activities are completed.

## 2. Crossing Techniques

Columbia typically utilizes either the dry-ditch (flume pipe) wet-ditch; or Dam and Pump techniques to install pipelines across waterbodies. Figures 18, 19 and 20 illustrate these methods. **Upland construction** techniques may be used for **intermittent waterbody** crossings without perceptible flow at the time of the crossing, provided that a culvert is **promptly** installed to carry stormwater flow across the trench area and the erosion and sediment control devices illustrated in Figure 17 are installed.

### ***Minor Waterbodies***

For crossings of coldwater fisheries and coolwater and warmwater fisheries considered significant by the state, install the pipeline using the dry-ditch method or Dam and Pump method, unless approved otherwise in writing by the appropriate state agency.

For other **minor waterbody** crossings, complete instream construction in the waterbody using the wet-ditch method within 24 hours (except for blasting and pneumatic chipping; see Section III.6.). Limit use of equipment operating in the waterbody to that needed to construct the crossing.

### ***Intermediate Waterbodies***

The wet-ditch method can be used for **intermediate waterbody** crossings. Only the equipment necessary for excavating the trench, lowering-in the pipe, and backfilling the trench is allowed in the waterbody. Columbia will attempt to complete trenching and backfill work in the waterbody within 48 hours, unless site-specific conditions make completion within 48 hours infeasible.

For crossings of coldwater fisheries and coolwater and warmwater fisheries considered significant by the state 10 to 30 feet in width, install the pipeline using the dry-ditch method or Dam and Pump method, unless approved otherwise in writing by the appropriate state agency.

### ***Major Waterbodies***

Due to their sensitive nature, **major waterbody** crossings will have site-specific construction plans approved by the Natural Resource Permitting



group. Directional drilling may be considered as an alternative for these crossings.

### **3. Clearing**

Tree and brush clearing will be performed as previously described in Section II, "Upland Construction". All cleared materials will be disposed of at least 50 feet from the water's edge.

### **4. Grading**

Grading equipment will not enter the water to grade the banks. Waterbody banks will be graded only where, and as much as, necessary to permit safe and efficient operation of construction equipment. During grading operations, sediment filter devices will be installed across the entire construction right-of-way promptly and as close to the water as practical. Removable sediment filter devices must be installed across the travel lane. These removable sediment filter devices, if removed during the day, must be re-installed by the end of the work day or when heavy precipitation is imminent. All disturbed areas within 50 feet of the water's edge will be promptly mulched. The mulch will be maintained until the waterbody crossing restoration is complete. Spoil from grading will be piled at least 10 feet from the stream banks and immediately protected with sediment filter devices so that it will not erode into the waterbody. On waterbody crossings with approaches sloped 5 percent or greater, interceptor diversions will be installed 50 feet from the water's edge to divert surface runoff into adjacent vegetation. If vegetation is sparse or nonexistent, a sediment filter device will be installed at the discharge of the diversion. Install a sediment filter device across the entire construction right-of-way at the base of slopes 5 percent or greater where the base of the slope is less than 50 feet from a stream. Leave adequate room between the sediment filter device and base of the slope for sediment deposition.

Construction equipment bridges consisting of culvert(s) with clean rock fill of non-erodable material or equipment pads as illustrated in Figures 21 and 22 will be installed during grading operations at all waterbodies. For proper culvert installation, the Inspector may permit grading/excavating equipment to enter the water. Equipment bridges are not required at minor waterbodies that do not have a state-designed fishery classification (for example, agricultural or intermittent drainage ditches). However, if an equipment bridge is used, it must be constructed in accordance with this ECS. Construct equipment bridges to maintain unrestricted flow and to prevent soil from entering the stream.

### **5. Trenching**

Notifications to applicable jurisdictional agencies will be made at least 2 days prior to any trenching in waterbodies, or as specified in permits

Prior to trenching within the waterbody, water impounded in the upland trench will be pumped into a into a sediment trap( Figure 14A) and/or properly installed filter bag (Figure 14B) and/or a series of terra tubes,

sediment logs or flocculent logs, or a heavily vegetated upland area where the water can filter back into the ground. Prevent the flow of spoil or heavily silt-laden water into any waterbody.

Sediment filter devices for trench spoil will be installed prior to commencing trenching activities. Sediment filter devices can be temporarily removed from the trench line only to allow trenching activities to proceed.

All spoil from minor and intermediate waterbody crossings, and upland spoil from major waterbody crossings, must be placed in the construction ROW at least 10 feet from the water's edge or in additional extra work areas.

For all new construction activities, the minimum depth of cover for all waterbody crossings is 48 inches in normal soils and 24 inches in consolidated rock.

Trench plugs will be used at all non-flumed waterbody crossings to prevent diversion of water into upland portions of the pipeline trench and to keep any accumulated trench water out of the waterbody. Trench plugs must be of sufficient size to withstand upslope water pressure.

For dry ditch method crossings, use sand bag or sand bag and plastic sheeting diversion structure or equivalent to develop an effective seal and to divert stream flow through the flume pipe (some modifications to the stream bottom may be required in to achieve an effective seal). In addition, do not remove flume pipe during trenching, pipelaying, or backfilling activities, or initial streambed restoration efforts.

## **6. Blasting**

During the pre-planning of waterbody crossings, an evaluation will be made concerning the need for blasting. If the evaluation is inconclusive, the waterbody bed will be tested for consolidated rock prior to trenching.

Blasting will not be done within waterbody channels without prior approval from applicable government authorities having jurisdiction and at least 2-day notice to the authority, or as specified in permits

If the waterbody bottom is consolidated rock, it can be drilled and shot at any time prior to commencing the crossing. However, removal of shot rock, and any additional drilling, shooting and material removal, must be completed within the minimum number of consecutive calendar days practical. The time frame for completing the crossing will immediately commence once a trench of appropriate dimensions is established.

## **7. Backfilling**

Waterbody bottoms will be returned as near as practical to their original contours. Spoil from the trench will be used as backfill. Clean gravel or native cobbles will be used for the final one-foot of fill in the backfilled trench in all coldwater fisheries.

The sediment filter devices removed at the stream will be promptly reinstalled after backfilling.

## **8. Restoration**

The preferred restoration method is to achieve final grade and restore the waterbody, its banks, and 50-foot buffers within 24 hours of backfilling. In the absence of site-specific seeding recommendations, the specifications listed in Table 2a will be used. If conditions do not permit the preferred method, the construction work area not in use for access will be promptly rough graded and stabilized in accordance with Table 2b.

Stabilize waterbody banks and install permanent sediment barriers/sediment filter devices within 24 hours of completing the crossing. For dry-ditch crossings, complete streambed and bank stabilization before returning flow to the waterbody channel.

Liquid mulch binders will not be used within 100 feet of waterbodies.

For each waterbody crossed, install a permanent interceptor diversion/slope breaker and a trench breaker at the base of slopes near the waterbody. Locate the trench breaker immediately upslope of the interceptor diversion/slope breaker.

All equipment bridges will be removed once access in the area is no longer required.

Return all waterbody banks to preconstruction contours or to a stable angle of repose as approved by the Environmental Inspector. If the waterbody banks are such that an unstable final soil grade would result and vegetative stabilization is inadequate, the Inspector will require mechanical stabilization of the waterbody banks. Mechanical stabilization includes riprap, gabions, jute netting, etc.

Unless otherwise specified by state permit, limit the use of riprap to areas where flow conditions preclude effective vegetative stabilization techniques, such as seeded erosion control fabric.

Revegetate disturbed riparian areas with conservation grasses and legumes or native plant species, preferably woody species.

Application of riprap must comply with the US Army Corps of Engineers, or its delegated agency, permit terms and conditions. In general, riprap will be of field or quarry run stone, which is hard and durable. The riprap will be large enough to prevent normal waterbody current from moving it, typically 6-inch rock for slow moving waterbodies and 12 inch or larger rock for others. The riprap will be placed at least 18 inches thick and generally thicker at the base. The riprap slope will be no steeper than 1:1 and should conform with the remainder of the waterbody bank slopes where they are flatter than 1:1.

Install erosion control fabric, figure 16, such as jute thatching or bonded fiber blankets at a minimum, on waterbody banks at the time of final bank re-contouring. Anchor the erosion control fabric with staples or other appropriate devices.

Sediment filter devices will be removed once permanent revegetation is successful.

## **B. Wetland Crossings**

### **1. General**

The main objective of any wetland crossing is to construct the pipeline and restore the original contour of the wetland. Wetlands will be clearly marked in the field by a knowledgeable person prior to the start of construction with signs and/or highly visible flagging until construction is complete. The Inspector will maintain these field markings during construction. A maximum 75-foot wide construction work area may be used through wetlands.

Mulch will not be used as a temporary erosion control measure in wetlands.

Aboveground facilities will not be located in any wetland, except where the location of such facilities outside of wetlands would prohibit compliance with US DOT regulations.

When water levels are temporarily high, the Inspector will direct that starting construction in the wetland will be postponed until after the water levels subside.

Standards relating to spill prevention at wetlands are contained in Section IV, "Spill Prevention".

### **2. Crossing Techniques**

For wetland crossings without standing water or saturated soils, upland construction techniques can be used provided the top 12 inches of soil taken from the trench is stockpiled separately from the remaining excavated material. The construction right-of-way may be used for access when the wetland soil is firm enough to avoid rutting or the construction right-of-way has been appropriately stabilized to avoid rutting (e.g., with timber riprap, prefabricated equipment mats, or terra mats). In wetlands that cannot be appropriately stabilized, all construction equipment other than that needed to install the wetland crossing shall use access roads located in upland areas. Where access roads in upland areas do not provide reasonable access, limit all other construction equipment to one pass through the wetland using the construction right-of-way.

Wetland crossings in non-saturated soil wetlands will be constructed in a manner that will minimize the amount of time construction activities are occurring in the wetland, such as the length of time the topsoil is segregated and the trench is open.

Wetland crossings with standing water or saturated soils will be constructed as separate construction entities, such that trenching, pipe installation, backfilling, and restoration are completed in the minimum

number of consecutive calendar days necessary. Clearing, grading and equipment crossing installations are not included as part of the separate construction entity. The “push-pull” or “float” technique of pipe installation will be utilized whenever water and other site conditions permit. Assemble the pipeline in an upland area unless the wetland is dry enough to adequately support skids and pipe.

If standing water or saturated soils are present or if construction equipment causes ruts or mixing of the topsoil and subsoil, use **low-ground-weight** construction equipment, or operate normal equipment on timber riprap (only 2 layers), prefabricated equipment mats or terra mats. Tree stumps, rock, gravel, soil imported from outside the wetland or brush will not be used to stabilize the construction work area or as equipment pads in wetlands. Remove all equipment mats, and timber riprap during restoration of the wetland.

Staging areas will be located at least 50 feet from the wetland edge except where the adjacent upland consists of actively cultivated or rotated cropland or other disturbed land and will be limited to the minimum necessary to construct the crossing. If topographic conditions do not permit a 50-foot setback, these areas must be located at least 10 feet from the wetland’s edge with prior approval from the Natural Resources Permitting group.

The only access roads, other than the construction work area, that can be used in wetlands without FERC approval are those existing roads that can be used with no modification and no impact on the wetland.

Limit construction equipment operating in wetland areas to that needed to clear the construction work area, dig the trench, fabricate and install the pipeline, backfill the trench, and restore the ROW. All other construction equipment shall use access roads located in upland areas to the maximum extent practicable. Where access roads in upland areas do not provide reasonable access, limit all other construction equipment to one pass through the wetland using the construction work area.

A typical wetland crossing is illustrated in Figure 23.

### 3. **Clearing**

Tree and brush clearing will be performed as previously described in Section II, “Upland Construction”. Cut vegetation off just above ground level, leaving existing root systems in place, and remove (vegetation) from the wetland for disposal.

### 4. **Grading**

Grading in wetlands will consist of the minimum necessary for safe and efficient equipment operation. Limit pulling of tree stumps and grading activities to directly over the trenchline. Do not grade or remove stumps or root systems from the rest of the construction work area in wetlands unless the Chief Inspector and **Environmental Inspector** determine that safety-related construction constraints require removal of tree stumps from under the working side of the construction work area. Areas where

stumps are removed will be noted by the Inspector so, if necessary, those areas can be replanted with woody vegetation as described in wetland restoration.

Where wetlands are adjacent to the construction right-of-way and the right-of-way slopes toward the wetland, install sediment barriers along the edge of the construction work area as necessary to prevent sediment flow into the wetland. Remove these sediment barriers after successful restoration has occurred.

Sediment filter devices will be installed promptly across the construction work area during grading at any wetland edge and maintained until construction work area revegetation is complete. Temporary interceptor diversions will be installed adjacent to wetlands. Locations for these devices are illustrated in Figure 23.

## **5. Trenching**

Sediment filter devices can be temporarily removed from the trenchline to allow trenching activities to proceed. Spoil piles will be protected with sediment filter devices, if determined necessary by the Inspector, to prevent the flow of spoil off the construction work area.

## **6. Blasting**

During the pre-planning of crossing wetlands with standing water or saturated soils, an evaluation will be made concerning the need for blasting. If the evaluation is inconclusive, the wetland will be tested for consolidated rock prior to trenching. If the wetland has consolidated rock, it must be drilled and shot as part of the single construction entity.

## **7. Backfilling**

If trench dewatering is required, the water will be filtered and discharged through a sediment trap (Figure 14A) and/or filter bag (Figure 14B) and/or a series of terra tubes, sediment logs or flocculent logs or into a heavily vegetated area outside the wetland (where the water will filter back into the ground), so that no heavily silt-laden water enters directly into a wetland or waterbody. Remove any dewatering structure as soon as possible after the completion of dewatering activities. Spoil from the trench will be used as backfill. The surface will be recontoured as closely as practical to the original condition so that drainage patterns will not be changed. The conserved topsoil layer will be returned to the surface after backfilling.

Sediment filter devices will be promptly installed after backfilling.

Where the pipeline trench may drain a wetland, construct trenchline barriers and/or seal the trench bottom as necessary to maintain the original wetland hydrology. For each wetland crossed, install a permanent interceptor diversion and trenchline barriers at the base of slopes near the boundary between the wetland and adjacent upland

areas. Locate the trenchline barriers immediately upslope of the interceptor diversion.

Concrete coating activities will not take place within 100 feet of any wetland.

## **8. Restoration**

For each wetland crossed, install a trench breaker at the base of slopes near the boundary between the wetland and adjacent upland areas. Install a permanent slope breaker/interceptor diversion across the construction right-of-way at the base of a slope greater than 5 percent where the base of the slope is less than 50 feet from the wetland, or as needed to prevent sediment transport into the wetland. In addition, install sediment barriers/sediment filter devices as shown in Figure 23. In some areas, with the approval of the Environmental Inspector, an earthen berm may be suitable as a sediment barrier adjacent to the wetland.

Consult with the appropriate land management or state agency to develop a project-specific wetland restoration plan. The restoration plan should include measures for re-establishing herbaceous and/or woody species, controlling the invasion and spread of undesirable exotic species (e.g., purple loosestrife and phragmites), and monitoring the success of the revegetation and weed control efforts.

Upon completion of construction in wetland areas with standing water or saturated soils, all access improvements will be promptly removed. In the absence of specific recommendations from conservation authorities, the seed mix and rate specified in Table 2c will be used. Fertilizer, lime or mulch will not be used, unless required in writing by a jurisdictional agency.

Asphaltic emulsions will not be used to stabilize mulch within 100 feet of wetlands. Liquid mulch binders will not be used within 100 feet of wetlands.

## **IV. SPILL PREVENTION, CONTAINMENT AND CONTROL**

### **A. General**

Spills of any amount of petroleum products or polluting materials are to be prevented. The following will be followed to help avoid spills and minimize the impact of spills, which accidentally occur:

- Bulk quantities up to 5,000 gallons of diesel fuel and 5,000 gallons of gasoline will be stored in one location (the fuel depot) for the Project. Adequate spill containment measures, such as containment dikes, combined with impervious lining will be installed before fuel storage tanks are filled, and will be maintained throughout the Project. Bulk quantities of hazardous liquids (e.g., solvents and lubricants) will be stored at the fuel depot locations.

- Generally, fuel will be stored at the equipment staging areas and as much equipment as practical will be refueled there. Any equipment that must be refueled in the field will be fueled from tanks carried to the work site. Fuel carriers (greater than 110 gallons capacity) will not be permitted to cross wetlands or ford waterbodies. Equipment refueling will not be performed within 100 feet of any body of water or wetland except by hand-carried cans (5 gallon maximum capacity) when necessary. If construction equipment must be refueled within 100 feet of a waterbody, follow the procedures outlined in the project-specific SPCC Plan. Care will be taken during refueling not to overfill or spill fuel onto the housing of equipment.
- Lesser quantities of fuel (up to 500 gallons) and solvents and lubricants (e.g., motor oils, hydraulic fluid) may be stored along the construction work area as necessary to service equipment used on the Project (quantities vary depending on the size of the construction spread being used), provided that this storage does not conflict with other parts of this plan. Sorbent booms and clean-up kits will be kept at all storage locations and will be readily available at all times.
- All fuel storage areas will be located at least 100 feet from streams, ponds, or wetlands; at least 200 feet from active private water wells, and at least 400 feet from municipal water wells, unless using an operational fuel storage area established on Columbia property. All fuel storage areas will not be located within any designated municipal watershed area (except at locations designated for these purposes by an appropriate governmental authority): Equipment servicing, lubricating and refueling will also be in accordance with these requirements whenever possible (i.e., except when stationary equipment such as drilling rigs is being used). Where these conditions cannot be met, the Environmental Inspector will prepare a supplemental SPCC plan, based on field conditions, to protect these resources.
- Use of hazardous materials for vehicle maintenance will follow the same requirements mentioned above for equipment refueling. Impervious or sorbent materials will be placed under the work area before the work begins. Additional sorbent materials will also be readily available. Waste materials created during maintenance (e.g., used oil) will be collected for proper disposal. The work site and the vehicle will be checked by a Columbia inspector after the maintenance work is complete to ensure that all hazardous materials are properly contained. All waste material, including partially used or empty containers, discarded parts, clean up rags, and used sorbent materials, as well as discarded hazardous materials containers (e.g., oil cans, grease tubes), will be collected for proper disposal.
- All motor fuel, lube oil, chemicals, and other polluting substances will be tightly sealed and clearly labeled during transportation and storage.
- Fuel trucks, pumps, mechanics' vehicles, the contractor's foremen's vehicles and Columbia Inspectors' vehicles will be equipped with appropriate sized spill kits containing absorbent materials approved for petroleum products and have sufficient tools and material to stop leaks.
- Construction equipment will not be washed in any body of water or wetland, nor will runoff resulting from washing operations be permitted to directly enter any body of water or wetland area.



- Construction equipment, vehicles, materials, hazardous materials, chemicals, fuels, lubricating oils, and petroleum products will not be parked, stored, or serviced within 100 feet of all bodies of water and wetlands.
- All equipment will be checked, by a Columbia inspector, daily for leaks prior to beginning work in bodies of water or wetlands. Steps will be taken to repair leaks or remove the equipment from service, if necessary.

If barge mounted equipment is to be employed, the contractor will develop specific spill-prevention plans to be reviewed and approved by Natural Resource Permitting group.

## **B. Spill Cleanup**

Spills occurring during construction, operation and maintenance are to be reported immediately to the Monitoring Center at 1-800-835-7191 in accordance with Columbia policies, plans and procedures (Plan Number 120.02.01). Columbia's Environmental Health and Safety department will be responsible for contacting the appropriate agencies, except as provided for below.

If the call to the Monitoring Center is not returned within 30 minutes and the spill has impacted water, the person discovering the spill or release will contact the National Response Center at 1-800-424-8802 and report the release. That person will continue calling the Monitoring Center until a representative is reached.

If a spill should occur, Columbia will ensure immediate action is taken to minimize the impact of the spill, and see that appropriate cleanup action is immediately undertaken.

In the event of a spill into or in the vicinity of bodies of water or wetlands, the following will occur immediately:

- the source will be immediately stopped;
- the spill will be contained by placing sorbing booms or constructing dikes;
- the spill will be collected with sorbing materials, skimmed off water surfaces with booms, and/or the contaminated soil will be excavated;
- the waste materials will be properly stored and disposed in accordance with Columbia policy.

The affected areas will be restored as closely as possible to their previous condition.

If the spill is such that Columbia personnel or the on-site contractor cannot immediately and effectively respond, Columbia's environmental contractor, who specializes in spill cleanup, will be employed.

## **V. MAINTENANCE**

### **A. General**

Maintenance of Columbia's ROWs is an ongoing process, which is governed by Columbia policy, certificate and permit conditions and landowner agreements. Full width vegetation maintenance clearing shall not be done more frequently than every 3 years. However, to facilitate periodic corrosion and leak surveys, a corridor not exceeding 10 feet in width centered on the pipeline may be maintained annually in a herbaceous state. In no case shall full width vegetation maintenance clearing occur between April 15 and August 1 of any year.

Maintenance activities will be performed with emphasis on preservation and enhancement of the environment. All applicable certificate and permit conditions will be incorporated into the future maintenance plan of the facility.

Specific procedures when required by regulations will be developed in coordination with the appropriate agency to prevent the introduction or spread of noxious weeds and soil pests resulting from construction and restoration activities.

## **B. Upland Areas**

Maintenance of facility ROW will be performed on the minimum width necessary to operate the facility.

Plant growth on the ROW will be inspected regularly and maintained for the life of the facility. Follow-up inspections will occur after the first and second growing season.

Revegetation in non-agricultural areas shall be considered successful if upon visual survey the density and cover of non-nuisance vegetation are similar in density and cover to adjacent undisturbed lands. In agricultural areas, revegetation shall be considered successful if crop yields are similar to adjacent undisturbed portions of the same field.

Continue revegetation efforts until revegetation is successful.

Monitor and correct problems with drainage and irrigation systems resulting from pipeline construction in active agricultural areas until restoration is successful.

ROW are generally maintained by mowing or other mechanical means, and through the use of herbicides. Use of herbicides will follow Columbia policy. Only those herbicides approved by the EPA will be used. Herbicide use will be in accordance with existing regulations and label instructions.

If revegetation is not successful, the area will be restored as soon as practical.

Problems with drainage and irrigation systems resulting from construction activities will be reported to the local Operations Team Leader. Corrective measures will be performed as needed.

Erosion problems on the facility ROW and access roads will be reported to the local Operations Team Leader or the Natural Resource Permitting group. Corrective measures will be performed as needed. Erosion control devices that are no longer required must be removed. Removal of the erosion control devices will be at the discretion of the local Operations Team Leader and the Engineering

& Construction department. Similarly, additional erosion control devices will be installed as required.

Maintain all temporary sediment barriers in place until permanent revegetation measures are successful or the upland areas adjacent to wetlands, waterbodies, or roads are stabilized. Remove temporary sediment barriers from an area once that area is successfully restored.

Efforts to control unauthorized off-road vehicle use, in cooperation with the landowner, shall continue throughout the life of the project. Maintain signs, gates, and vehicle trails as necessary.

### **C. Waterbodies, Wetlands, and Environmentally Sensitive Areas**

Columbia will work cooperatively with appropriate government agencies in an effort to minimize the impacts of ROW maintenance in waterbodies, wetlands, and other environmentally sensitive areas.

Limit vegetation maintenance adjacent to waterbodies to allow a riparian strip at least 25 feet wide, as measured from the waterbody's mean high water mark, to grow. Figure 24 illustrates ROW maintenance standards near waterbodies.

Do not use herbicides or pesticides in or within 100 feet of a waterbody or wetland except as specified by the appropriate land management or state agency.

In wetlands, a corridor up to 10 feet wide centered on the pipeline will be maintained in a herbaceous state. In addition, trees that are located within 15 feet of the pipeline and greater than 15 feet tall may be selectively cut. All felled trees will be removed from the wetland.

Attempts will be made to prevent the invasion or spread of undesirable exotic vegetation (i.e., purple loosestrife and phragmites) within wetland areas disturbed during construction. Typically, these efforts include Columbia's wetland construction techniques and the use of approved herbicides.

Monitor the success of wetland revegetation annually for the first 3 years after construction or until wetland revegetation is successful. Revegetation should be considered successful if the cover of native herbaceous and/or woody species is at least 80 percent of the total area, and the diversity of native species is at least 50 percent of the diversity originally found in the wetland. If revegetation is not successful at the end of 3 years, develop and implement (in consultation with a professional wetland ecologist) a remedial revegetation plan to actively revegetate the wetland with native wetland herbaceous and woody plant species. Continue revegetation efforts until wetland revegetation is successful.

For certain locations through Columbia's system listed threatened, endangered, or special concern species and their habitats have been identified. In addition, eligible cultural resources, wetlands, and other environmentally sensitive areas may also have been identified. In these instances, permits normally include maintenance provisions that must be adhered to for the life of the facility.

## **VI. ENVIRONMENTAL CONSTRUCTION MANAGEMENT AND INSPECTION**

### **A. General**

Columbia is responsible for compliance with the environmental conditions contained in a Projects' EM&CP, which include all permits and other approvals. One or more Environmental Inspectors will be assigned to every Project and will report to the Natural Resources Permitting group. At least one Environmental Inspector is required for each construction spread during active construction or restoration. Environmental Inspectors shall have peer status with all other activity inspectors.

### **B. Environmental Inspector**

The Environmental Inspector is responsible for assuring that the construction activity is performed in accordance with the environmental conditions of the EM&CP and landowner requirements and have the authority to stop work and order appropriate corrective action as outlined in Section VI.E. For construction activities that are found by the Natural Resource Permitting group to have minimal environmental impacts, the Environmental Inspector may also serve to monitor other construction functions.

At a minimum, the Environmental Inspector(s) shall be responsible for:

- ensuring compliance with the requirements of the EM&CP, ECS, and any permits, landowner agreements or FERC certificates obtained for the Project;
- Identifying, documenting and overseeing corrective actions, as necessary to bring an activity back into compliance.
- verifying that the limits of authorized construction work areas and locations of access roads are properly marked before clearing;
- verifying the location of drainage and irrigation systems;
- identifying erosion/sediment control and stabilization needs in all areas;
- locating dewatering structures and interceptor diversions to ensure they will not direct water into known cultural resource sites or locations of sensitive species;
- verifying that trench dewatering activities do not result in the deposition of sand, silt, and/or sediment near the point of discharge into a wetland or waterbody. If such deposition is occurring, the dewatering activity shall be stopped and the design of the discharge shall be changed to prevent reoccurrence;
- verifying the testing of subsoil and topsoil in agricultural and residential areas to measure compaction and determine the need for corrective action;
- advising the Chief Inspector when conditions (such as wet weather) make it advisable to restrict construction activities in agricultural areas;

- ensuring restoration of contours and topsoil;
- verifying that the soils imported for agricultural or residential use are noxious weed free certified;
- ensuring that temporary erosion controls are properly installed and maintained, daily if necessary;
- inspecting temporary erosion control measures at least on a daily basis in areas of active construction or equipment operation, on a weekly basis in areas with no construction or equipment operation, and within 24 hours of each 0.5 inch of rainfall; This responsibility may be transferred to field operations after construction is complete but before restoration is successful.
- ensuring the repair of all ineffective temporary erosion control measures within 24 hours of identification;
- keeping records of compliance with the environmental conditions of the (EM&CP and any certificates) and other federal or state environmental permits during active construction and restoration;
- establishing a program to monitor the success of restoration. Implementation of this program may be transferred to (Field Services) upon completion of construction and restoration activities;
- looking for evidence of contamination and, if found, cease activities in that area and notify the Environmental Health & Safety department and the Natural Resource Permitting group and wait for further instruction. If the contamination is determined to be hazardous, an experienced hazardous waste contractor will be mobilized to handle the waste; the hazardous waste contractor will follow a site-specific health and safety plan and standard operating procedures for working in hazardous environments, which is maintained by the Environmental Health & Safety department; and
- verifying the location of signs and visible flagging marking the boundaries of wetlands, waterbodies and other environmental sensitive areas.

### **C. Environmental Training**

The Engineering & Construction Team Leader assigned to the construction activity and/or the Columbia employee in responsible charge, will be responsible for assuring that the Environmental Inspector(s), other inspectors and any contractor's foreman have been trained in all environmental aspects of the activity, and fully understands the environmental conditions contained in the activity's EM&CP.

The Natural Resource Permitting group staff will conduct training for construction personnel when sensitive resource issues are present, when permit/certificate conditions mandate, or when requested by the Team Leader.

### **D. Contractor's Environmental Compliance Specialist (Environmental Foreman)**

For construction activities that utilize an outside contractor, the contractor will be required to provide at least one environmental compliance specialist. This specialist will become thoroughly familiar with Columbia's EM&CP for the activity.

The specialist will be responsible for the contractor's efforts to correctly install and maintain environmental control devices and for construction in environmentally sensitive areas. Contractor's specialist will work in cooperation with Columbia's employees responsible for environmental compliance.

The Contractor's Environmental Foreman must be available at all times during the project and have the appropriate number of available employees to adequately implement the project's EM&CP.

#### **E. Environmental Construction Management**

The Environmental Inspector and each functional inspector shall have the authority to stop work on a particular construction function to which they are assigned if it deviates from the environmental conditions of the activity's EM&CP. The deviation shall be reported immediately to the Columbia employee in responsible charge of the activity and the Environmental Inspector. The Columbia employee in responsible charge, the Engineering & Construction Team Leader and the Natural Resource Permitting group department will be responsible for the resolution of the deviation.

Stop work authority for the entire construction activity rests with the Columbia employee in responsible charge or the Engineering & Construction Team Leader.

The Natural Resource Permitting group may, from time to time, perform inspections of construction activities to review the implementation of the EM&CPs. The Natural Resource Permitting group will have stop work authority during these inspections should deviations from the activity's EM&CP occur. Any corrective actions that are required shall be taken as directed by the Natural Resources Permitting group.

#### **F. Environmental Variances**

Unapproved variances from an EM&CP and this ECS are not permitted. Any proposed variance from an EM&CP will require approval from the EM&CP preparer, prior to commencing the activity. The approval for a variance will be in writing. In instances where written approval is not practical (i.e., emergencies and weekends), verbal approval may be given provided that written confirmation is provided as soon as possible.

Any proposed variance from this ECS will require approval from the Natural Resource Permitting group prior to commencing the activity.

### **VII. EMERGENCY CONSTRUCTION**

In the event of an emergency, the Company employee in responsible charge will take such action as is necessary to contain the emergency giving due regard to minimizing environmental impact. In conjunction with other Columbia policies, the requirements contained in this ECS will be followed as close as possible.

<sup>1</sup> Will include all environmental and regulatory mandated surveys such as but not limited to, threatened and endangered species surveys, archeology surveys, wetland delineations etc.

<sup>2</sup> Deviations that involve measures different from those contained in this ECS will only be permitted by written approval from the Natural Resource Permitting group. The Natural Resource Permitting group may be required to obtain written approval from the Director of the Office of Pipeline Regulation (OPR) (Federal Energy Regulatory Commission), or his/her designee, unless specifically required in writing by another Federal, state, or Native American land management agency for the portion of the project on its land. The Natural Resource Permitting group shall coordinate the filing of other agency requirements with the Secretary of the Commission (Secretary). This filing shall be prior to construction.

## **VIII. DEFINITION OF TERMS\***

**AGRICULTURAL LANDS:** Permanent or rotated croplands, hayfields, and pastures.

**COLUMBIA:** Columbia Gulf Transmission Corporation

**COE:** U.S. Army Corps of Engineers

**CONSTRUCTION WORK AREA:** Construction work areas include permanent and temporary ROW, contractor's yards, pipe and materials storage yards, and access roads.

**ECS:** Environmental Construction Standards

**ENVIRONMENTAL INSPECTOR:** The Inspector responsible for environmental compliance on a construction project.

**EPA:** Environmental Protection Agency

**FWS:** U.S. Fish and Wildlife Service

**EM&CP:** Environmental Management and Construction Plan

**EXCEPTIONAL VALUE WATER(S):** A stream or waterbody which constitutes an outstanding national, State, regional or local resource, such as waters of national, State or county parks or forests, or waters which are used as a source of unfiltered potable water supply, or waters of wildlife refuges or State game lands, or waters which have been characterized by the Fish Commission as "Wilderness Trout Streams." and other waters of substantial recreational or ecological significance.

**FINAL GRADING:** Includes returning the construction work area as closely as practical to its original contour, redistributing conserved topsoil, soil compaction testing in agricultural lands, and installing final interceptor diversions.

**HIGH QUALITY STREAM:** A cold water fishery or significant warm water fishery as designated by a state resource agency.

**IMMEDIATE:** Without interval of time; "right now".

**INSPECTOR:** Collectively: the Chief Inspector, Environmental Inspector, Utility Inspector, or any other inspector assigned to do an environmental task.

**INTERMITTENT WATERBODY:** A waterbody channel which generally carries water in the spring or immediately after a rain event; designated on topographic maps and environmental construction drawings with a broken line.

**INTERMEDIATE WATERBODY:** A waterbody greater than 10 feet wide at the water's edge at the time of construction but less than or equal to 100 feet wide.

**LOW-GROUND-WEIGHT:** Construction equipment that is designed "specifically for" or "frequently used in" areas where compaction and sinking is to be minimized. This equipment can be less than 5 lbs/in<sup>2</sup> or contain wider tracks than the standard minimum size width tracks for the model equipment to be used.

**MAJOR WATERBODY:** A waterbody greater than 100 feet wide at the water's edge at the time of construction.

**MINOR WATERBODY:** A waterbody less than or equal to 10 feet wide at the water's edge at the time of construction.

**MSDS:** Material Safety Data Sheet

**NRCS:** Natural Resource Conservation Service

**NOISE SENSITIVE AREA:** Includes residences, schools, churches, cemeteries, hospitals, farms, camping facilities and outdoor amphitheaters and playgrounds.

**ORV:** Off-road vehicle.

**PERENNIAL WATERBODY:** A waterbody which generally flows all year in years of normal rainfall; waterbody level is generally lowest in the fall, highest in the spring; designated with a solid line on topographic maps and environmental construction drawings.

**PROMPTLY:** By the end of the work day.

**RESTORATION:** Includes fertilizing, liming, disking, seeding and mulching, and crimping mulch.

**RIVER:** A waterbody which is 100 feet wide or more.

**ROW:** Right-of-way.

**SCARIFY:** To make shallow cuts into the soil surface. This should be accomplished with a disk, rake, tracked equipment (grousers) or other suitable means.

**SEDIMENT FILTER DEVICE:** Properly embedded silt fence or staked bales (Figures 7 & 8).

**SPCC:** Spill Prevention Control and Countermeasure Plan

**STEEP SLOPE:** Slope of 33% or greater.

**TEMPORARY STABILIZATION:** Includes installing temporary interceptor diversions and sediment filter devices, mulching critical areas and at times, seeding to hold soil in place until final grading and restoration can be accomplished.



**UPLAND CONSTRUCTION:** All areas which are not waterbodies, rivers, streams, or wetlands.

**WATERBODY:** Includes any natural or artificial waterbody, river, or drainage with perceptible flow at the time of crossing, and other permanent waterbodies such as ponds and lakes.

**WETLAND:** An area of special concern with soils prone to holding water for long periods of time, generally also characterized by distinctive plants such as rushes, sedges, cattails, or certain trees. Includes any area that satisfies the requirements of the current Federal methodology for identifying and delineating wetlands.

*\*Includes all grammatical variations of each term.*

**IX. TABLES**

**TABLE 2A  
SEED MIX REQUIREMENTS FOR ROW AND WATERBODY CROSSINGS**

<b>Type</b>		<b>Rate (lbs/acre)</b>
Seed <sup>1</sup>	Orchard Grass and/or Tall Fescue <sup>2</sup>	20
	Birdsfoot-trefoil (Empire) <sup>3</sup>	7
	Annual Rye	10
Fertilizer	10-10-10 (or equivalent)	600 <sup>4</sup>
Agricultural Lime		4000
Mulch	Hay or Straw	4000
<sup>1</sup> Pure live seed within 12 months of testing. <sup>2</sup> If tall fescue is used, plant endophyte-free certified seed. <sup>3</sup> Legumes to be inoculated by manufacturer's recommendations, if not available legumes are to be inoculated at 4 times recommended rate for conventional methods. 10 times recommended rate for hydroseeding. <sup>4</sup> Where wood chips are spread, additional nitrogen (12 to 15 lbs per ton of chips) will be spread.		

**TABLE 2B  
SEED MIX FOR TEMPORARY STABILIZATION**

<b>Type</b>		<b>Rate (lbs/acre)</b>
Seed	Annual Rye	40
Mulch	Hay or Straw	6000

**TABLE 2C  
SEED MIX REQUIREMENTS IN WETLANDS**

<b>Type</b>		<b>Rate (lbs/acre)</b>
Seed*	Annual Rye	40
*Annual Rye is used as a temporary revegetative measure until indigenous plants re-establish cover. A monitoring program will be in effect to insure adequate cover is established.		

X. FIGURES

A. Figure 1 – Typical Upland Pipeline Construction Sequence

B.

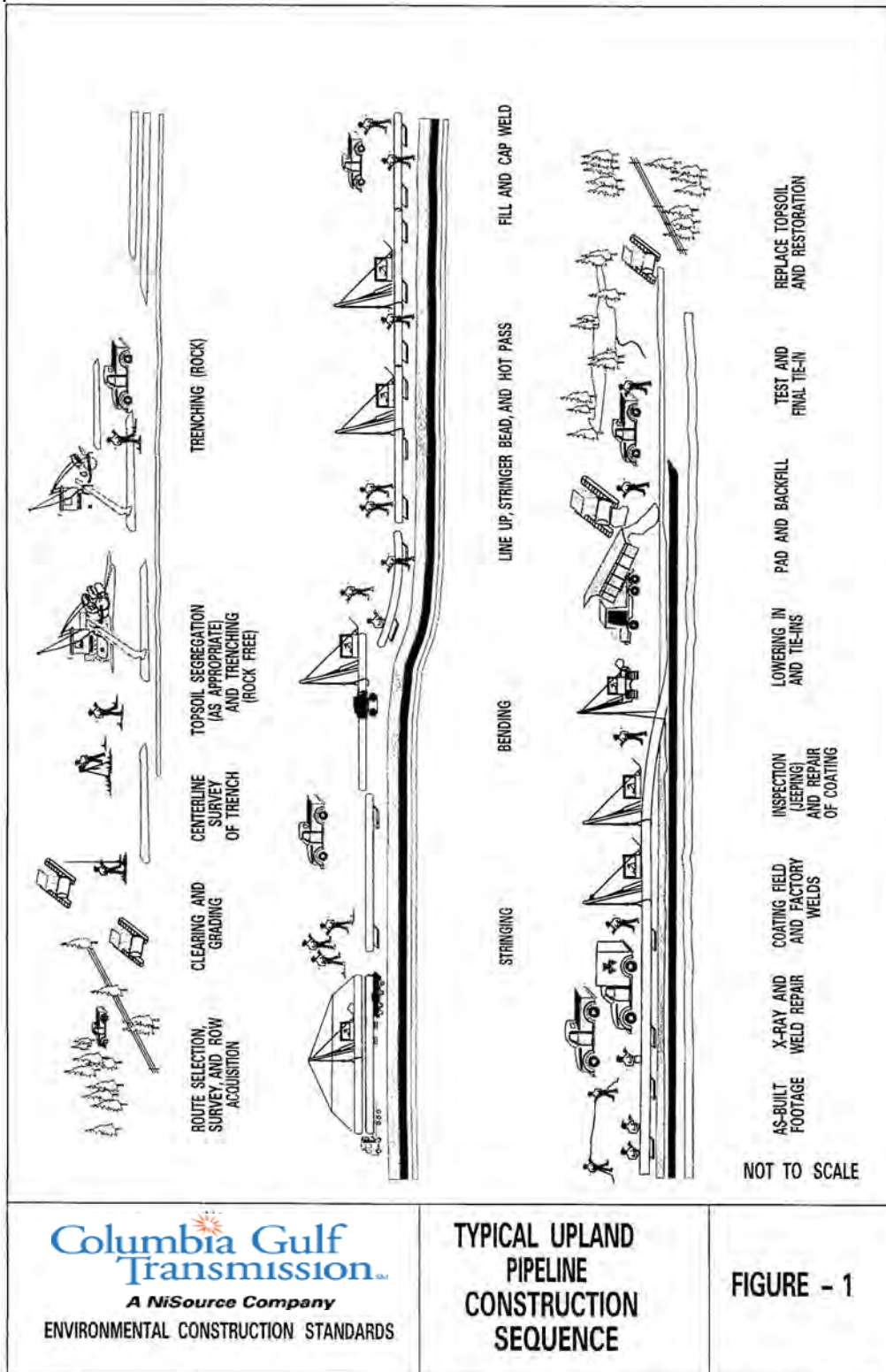

B.

**Columbia Gulf Transmission**  
*A NiSource Company*  
 ENVIRONMENTAL CONSTRUCTION STANDARDS

**TYPICAL UPLAND PIPELINE CONSTRUCTION SEQUENCE**

**FIGURE - 1**

Figure 2 – Typical 75 ft. Construction Right-of-Way

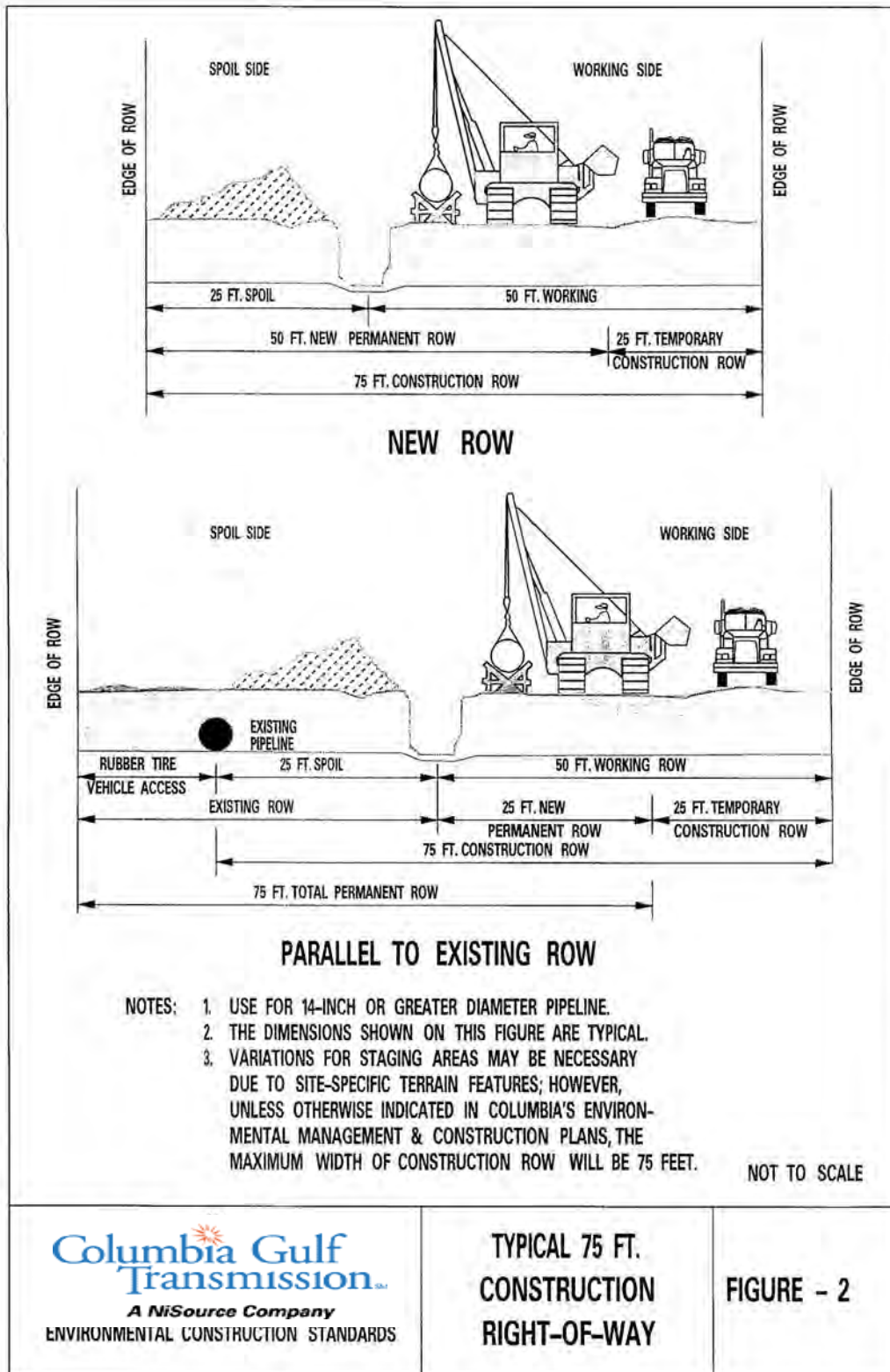

C. Figure 3 – Typical 50ft. Construction Right-of-Way

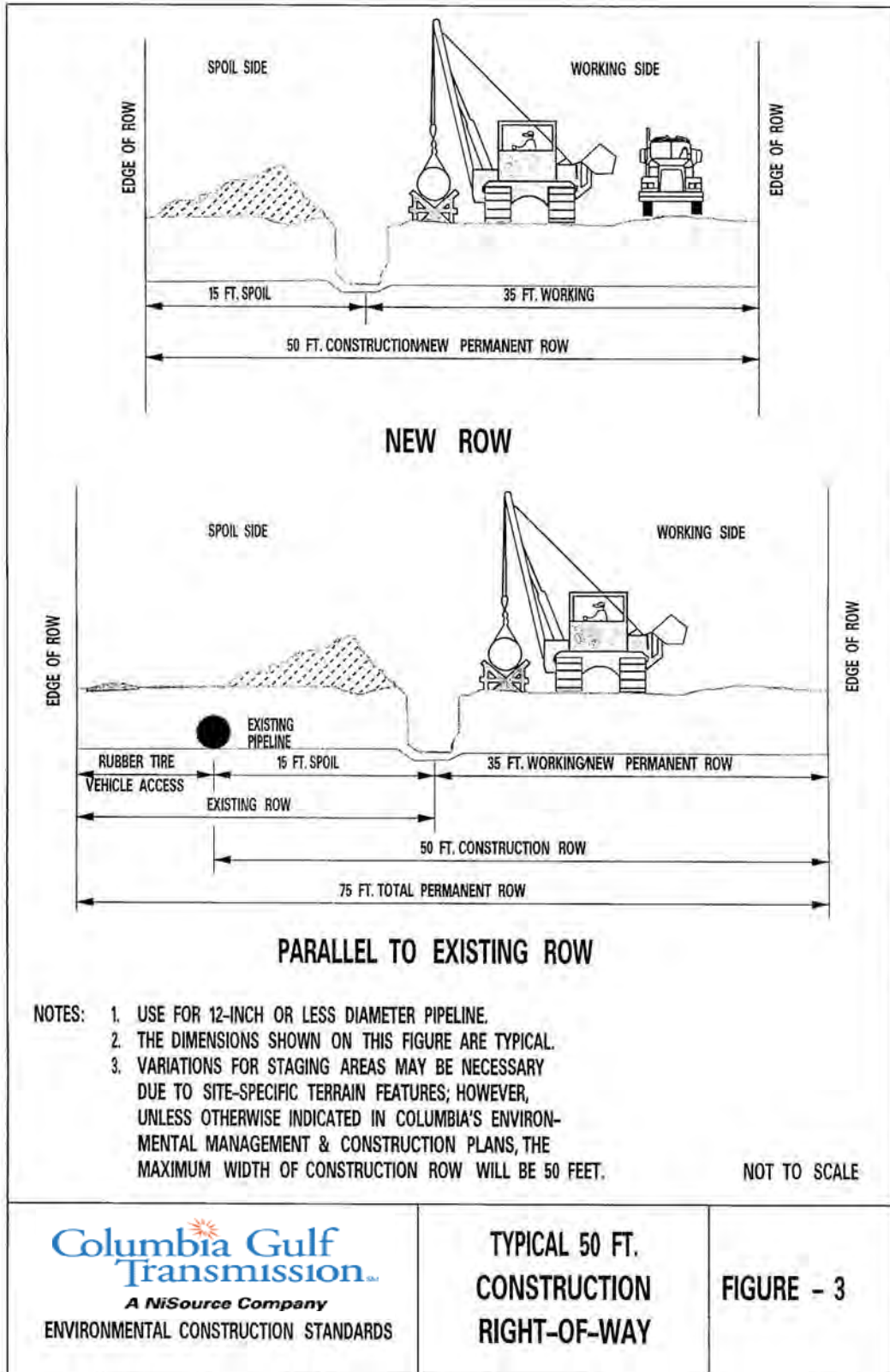

D. Figure 4 – Temporary Construction Gate

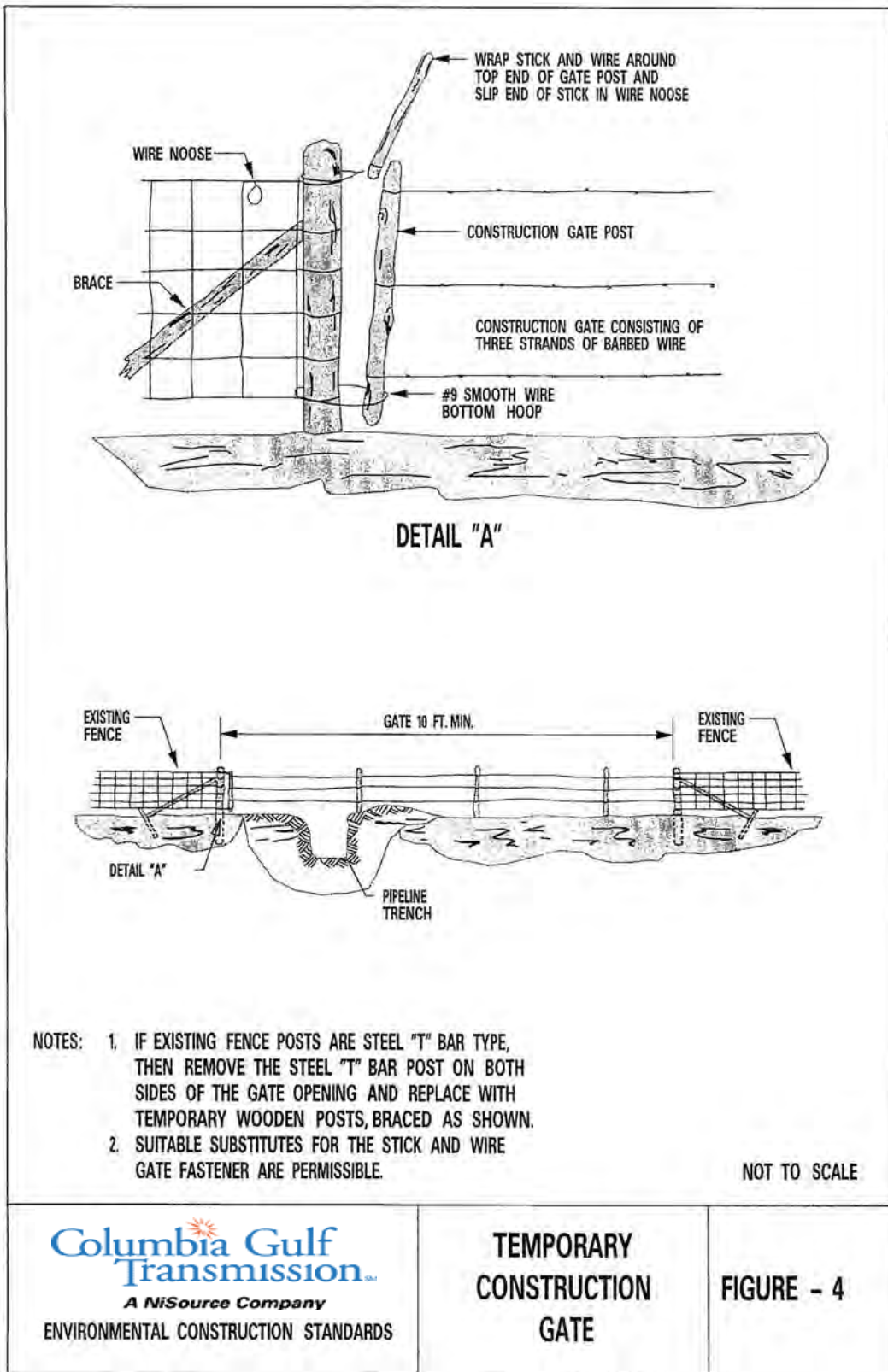

E. Figure 5 – Typical Soil Conservation

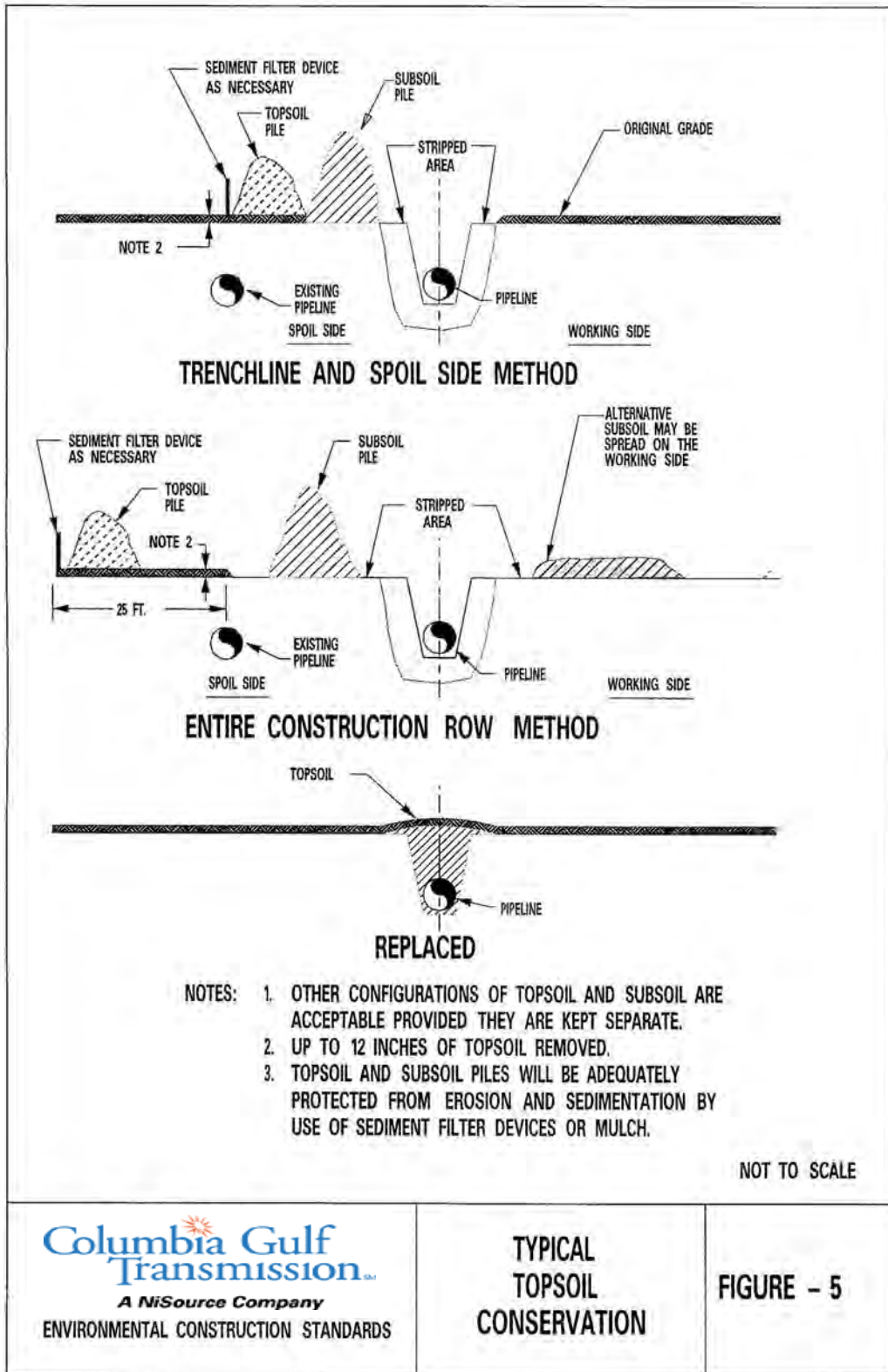

F. Figure 6A - Interceptor Diversions/Slope Breakers

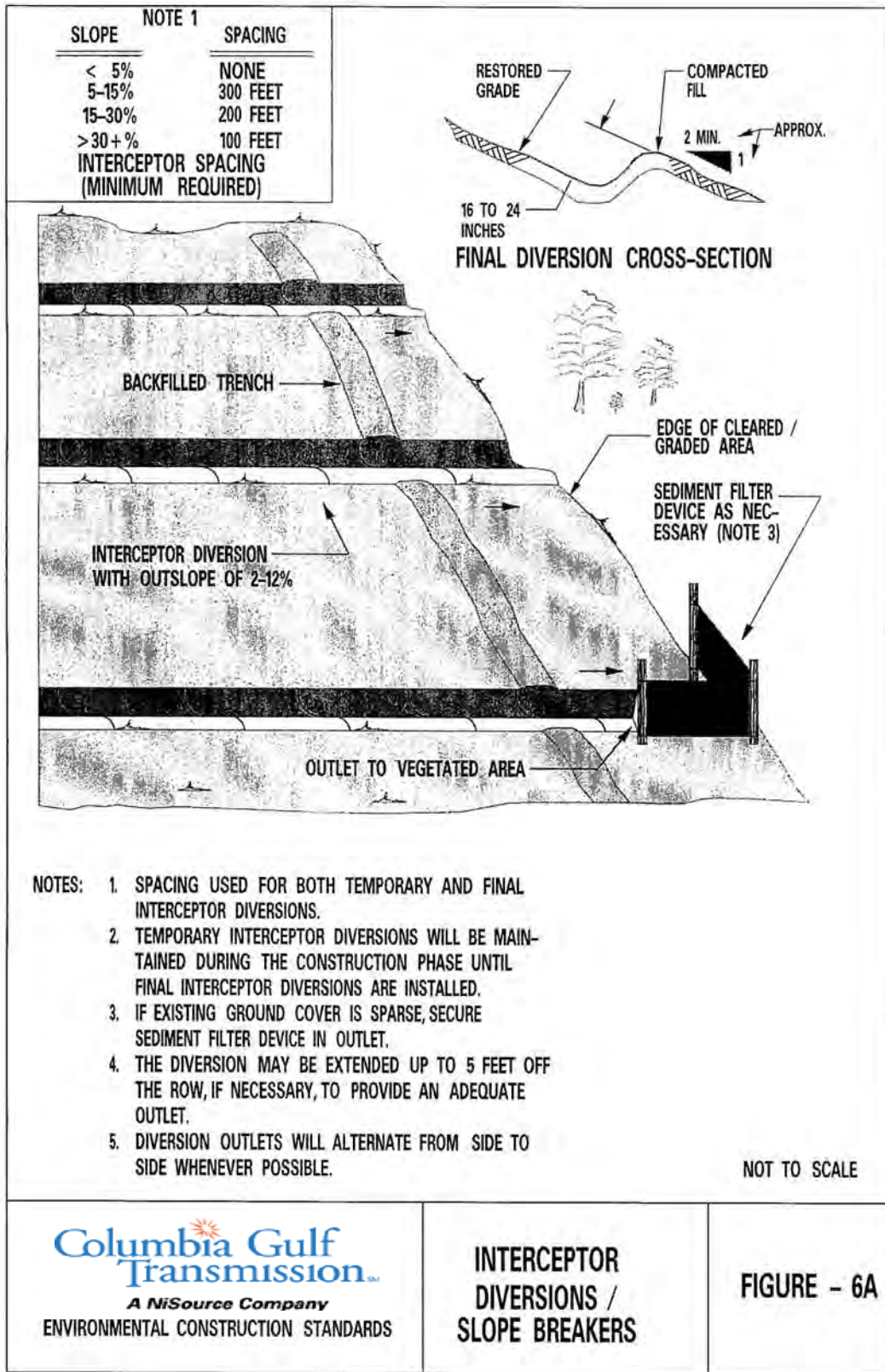



**G. Figure 6B – Interceptor Diversions**

**INTERCEPTOR DIVERSIONS /SLOPE BREAKERS**

Interceptor diversions are the most common and effective device used for erosion control on construction ROW. During construction, temporary diversions are installed to control water on the graded ROW. During restoration final diversions are installed to protect the ROW from erosion until the vegetation reestablishes on the disturbed areas.

Temporary diversions are generally made by building a curb 8 to 14 inches high across the ROW. The curbs are shaped to allow passage of construction equipment and inspector vehicles. The diversion should have a gradient of 2%– 12%, and must drain either into the trench or off the ROW. Where water is directed off the ROW, the outlet will be protected by a sediment filter device or heavy vegetation. Temporary diversions may be broken down by construction equipment during the workday, but will be restored by the end of each day. Temporary diversions will be spaced along the ROW in accordance with Figure 6A. The actual number of temporary diversions may vary from that of final diversions because the construction ROW's artificial grade may reduce the slope. Temporary diversions may be constructed out of silt fence, staked hay or straw bales or sand bags with the Environmental Inspectors approval. Position the outfall of each temporary slope breaker to prevent sediment discharge into wetland, waterbodies, or other sensitive areas.

Final diversions typically consist of a curb 16 to 24 inches high below a shallow swale. The curb is constructed of compacted earth fill with side slopes of 2:1 or flatter to allow passage of maintenance equipment. The diversions should extend across the entire ROW and drain water with a 2% to 12% gradient. The outlets of final diversions are stabilized with sediment filter devices, rock, brush, or heavy vegetation. Final diversions will be spaced along the ROW in accordance with Figure 6A (or as shown on the Environmental Construction Drawings), and will tie into existing diversions where present. In places where final grade creates side slopes or slopes which break in more than one direction, diversion installation may need to vary to create an outslope of 2% to 12% which will carry water off the ROW.

Alternative diversion construction may be used in areas where an earthen diversion is impractical. In these instances, temporary diversions may be constructed with sediment filter devices as noted above.

H. Figure 7 – Sediment Filter Device Silt Fencing

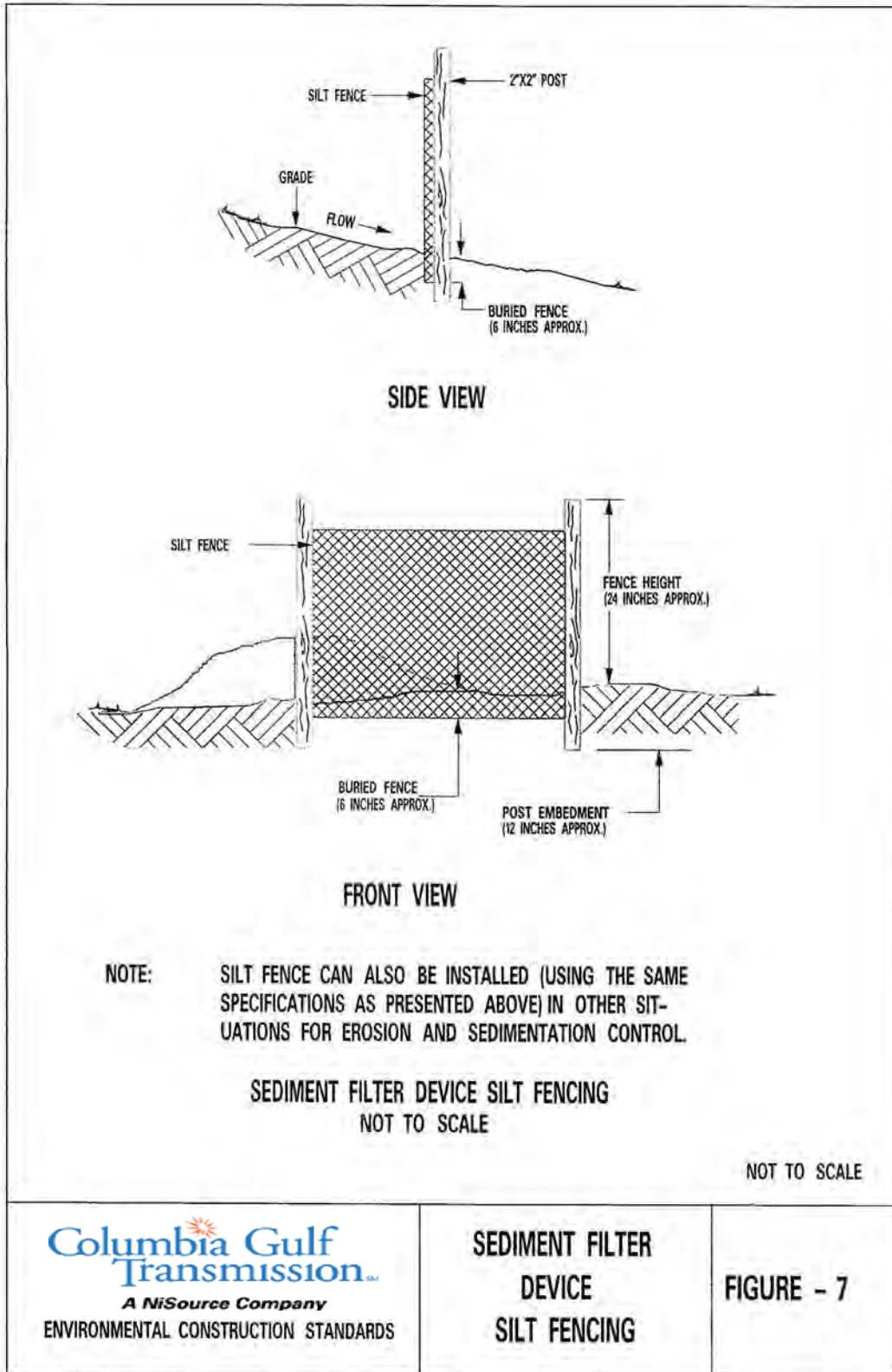

I. **Figure 8 – Sediment Filter Device Staked Bales**

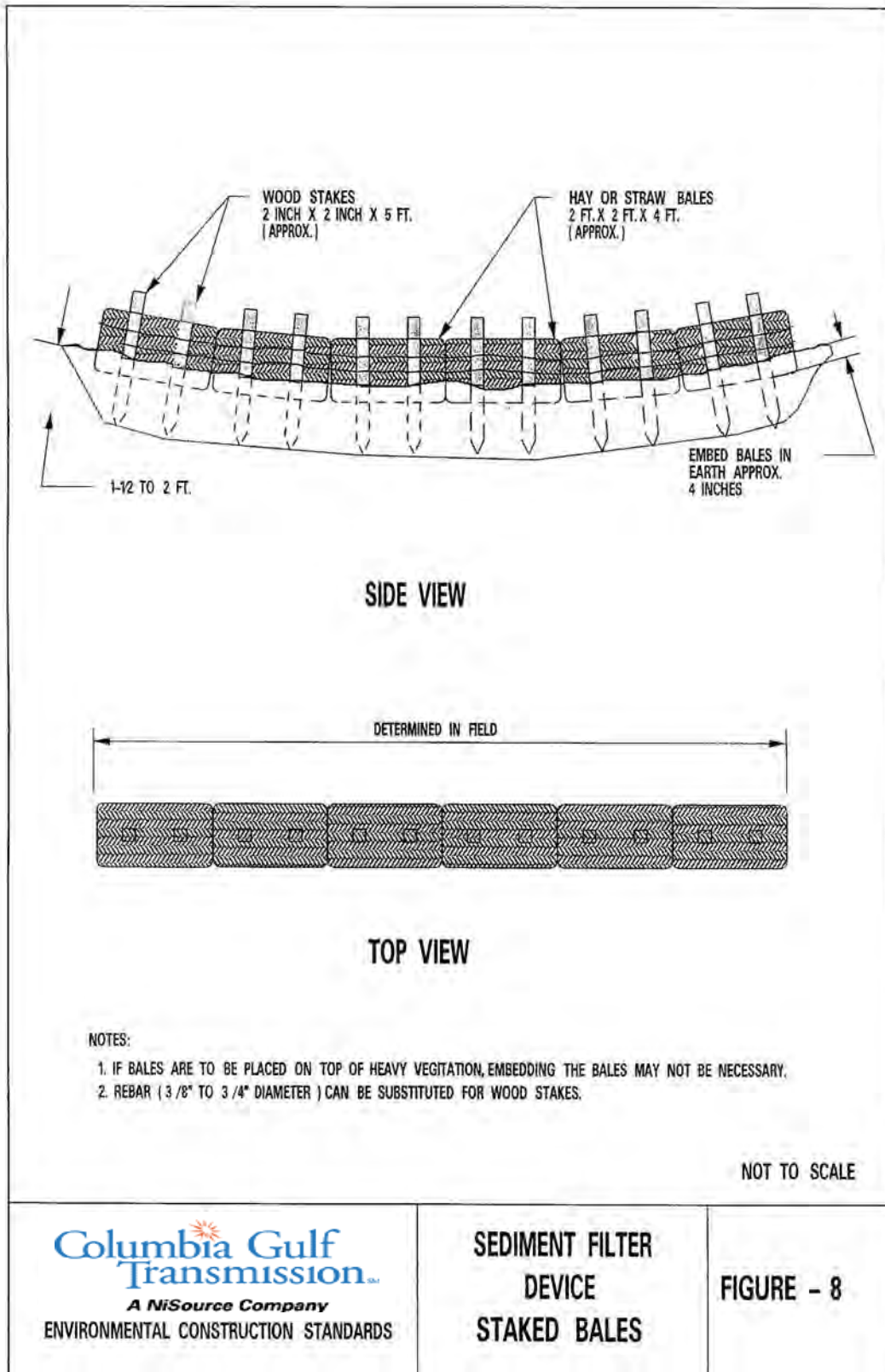

J. Figure 9 – Temporary Road Entrance Rock Pads

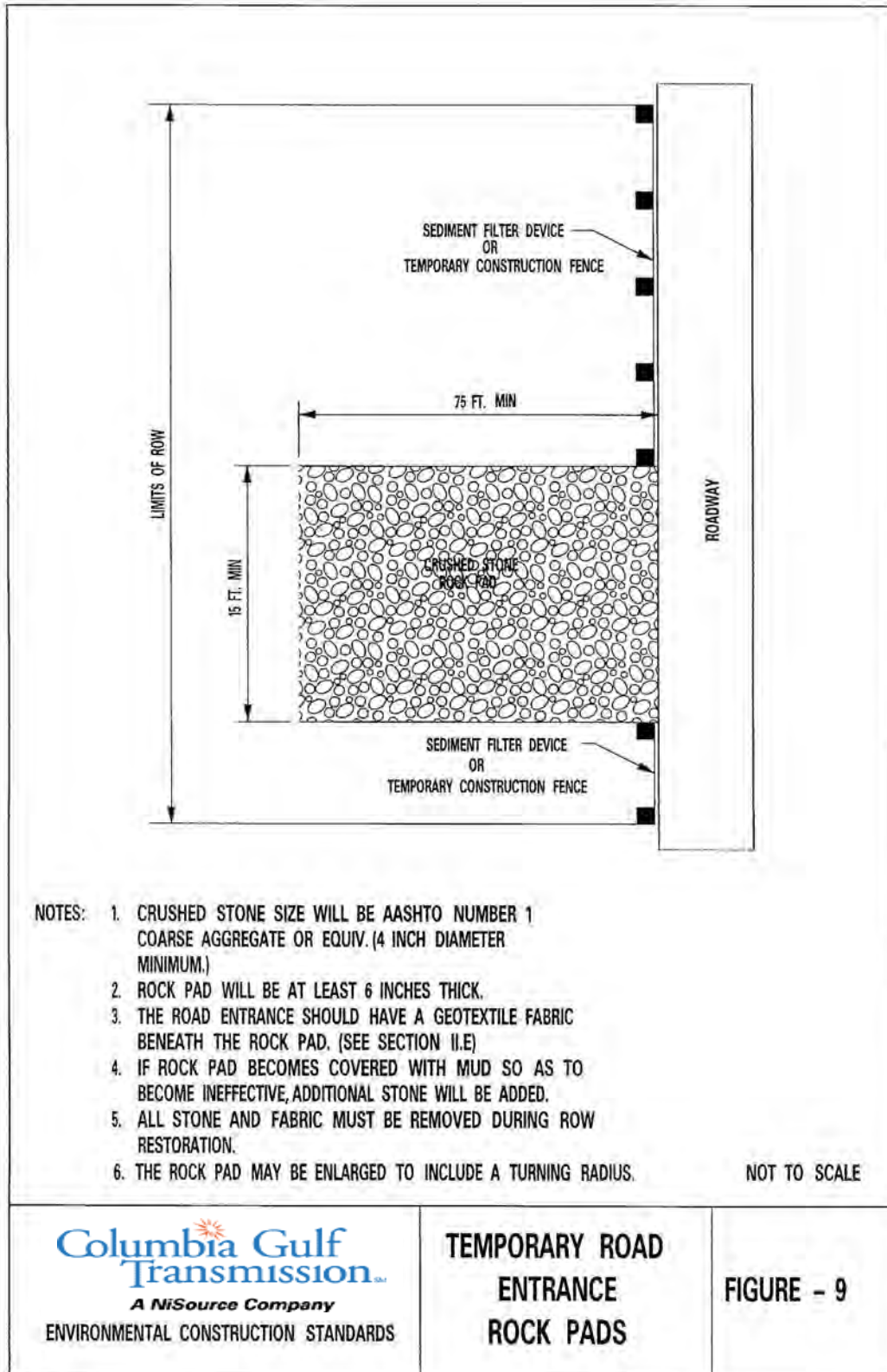

K. Figure 10 – Temporary Road Entrance Terra-Mats

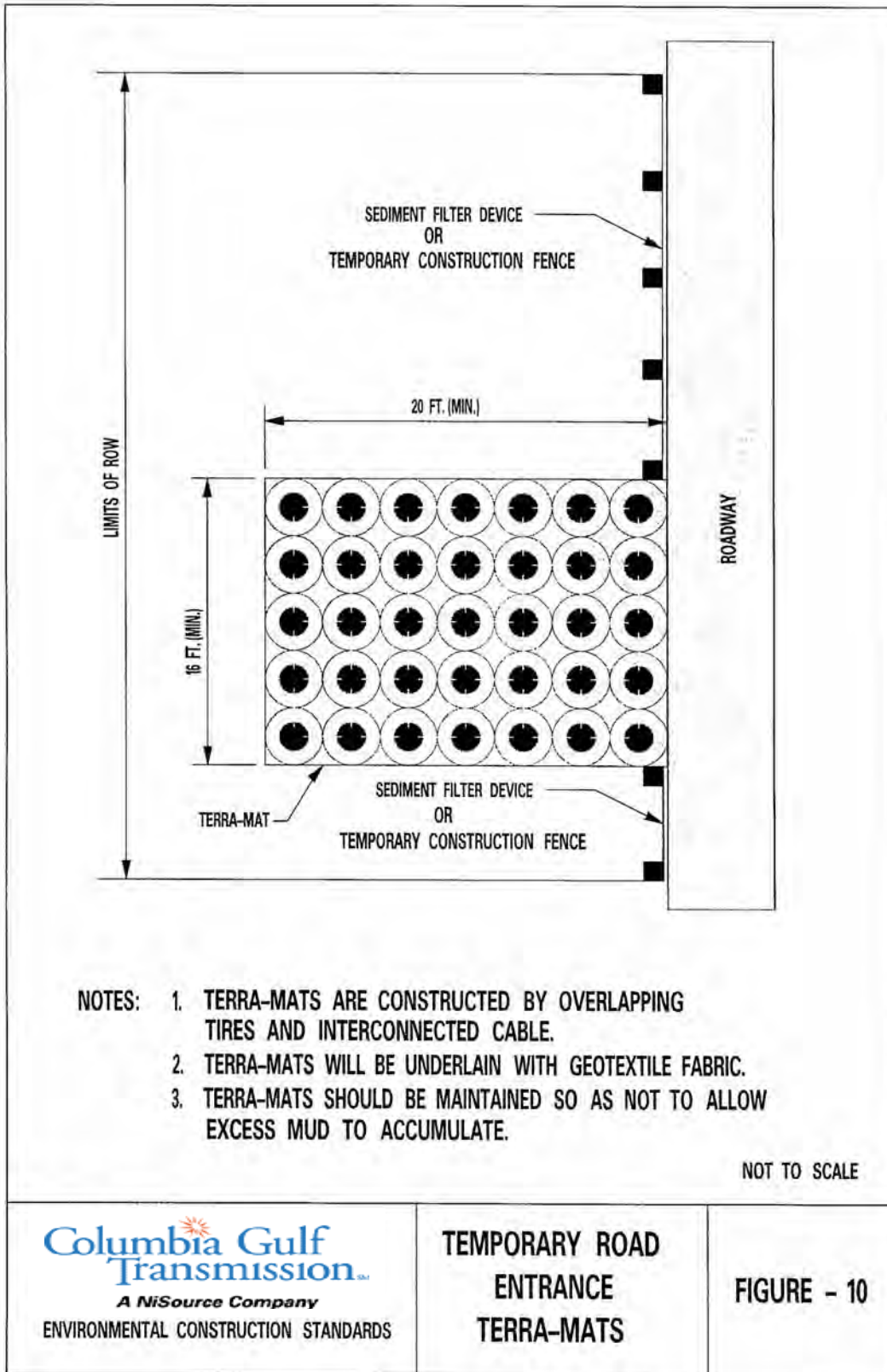

L. Figure 11 – Temporary Road Entrance Board Road

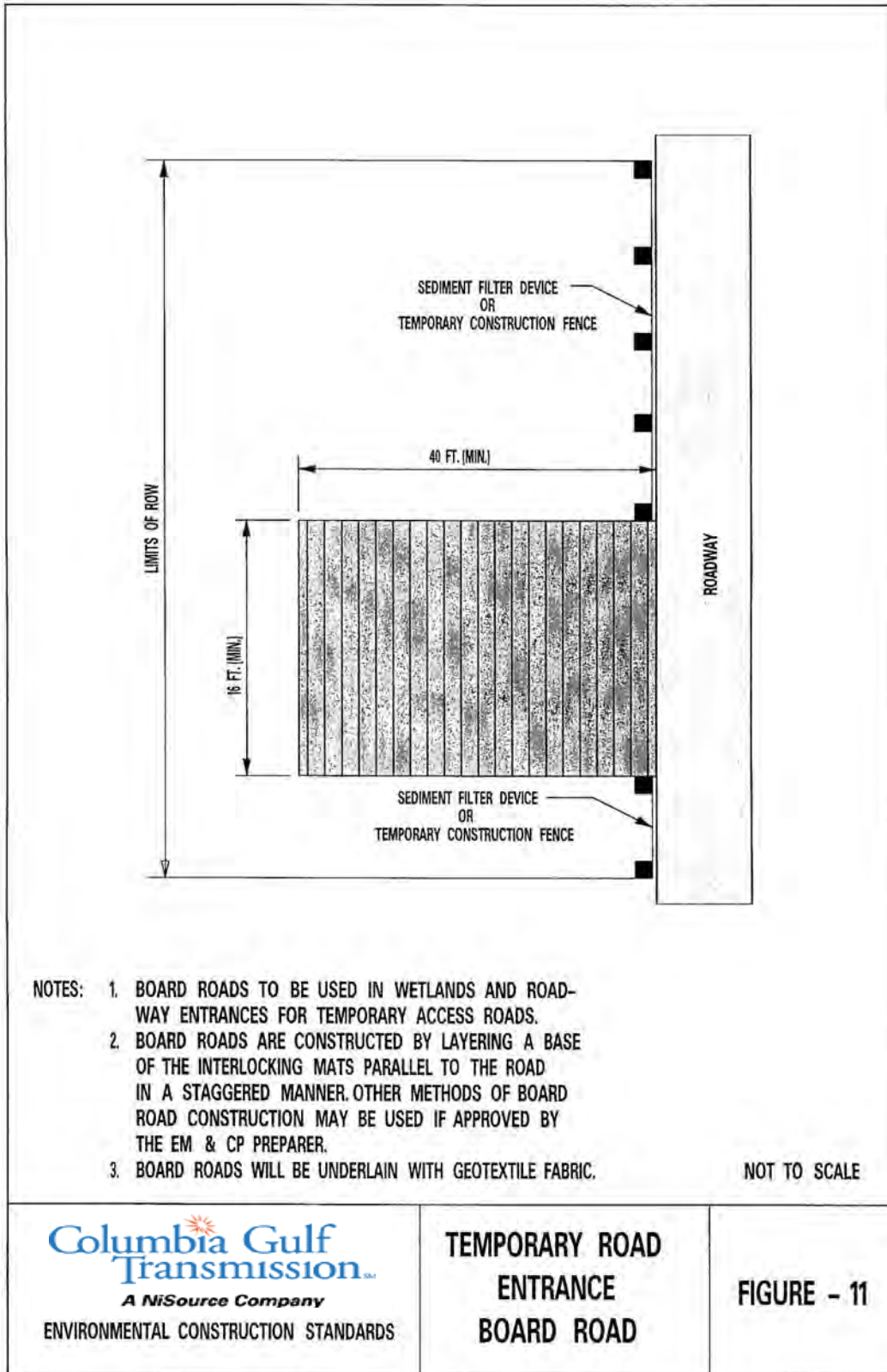

M. Figure 12 – Typical Erosion Control Measures at Road Crossings

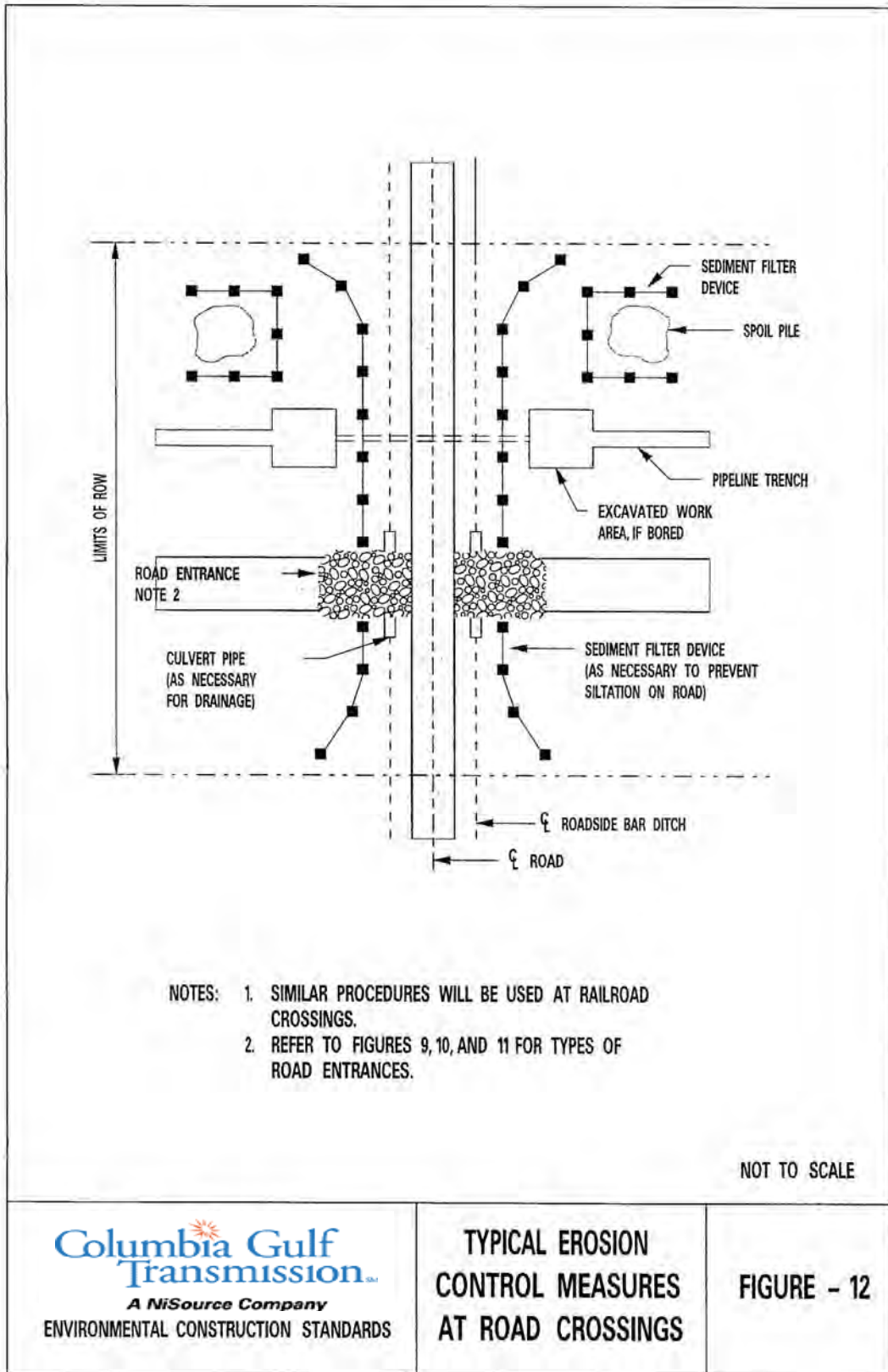

N. Figure 13 – Trenchline Barriers and Breakers

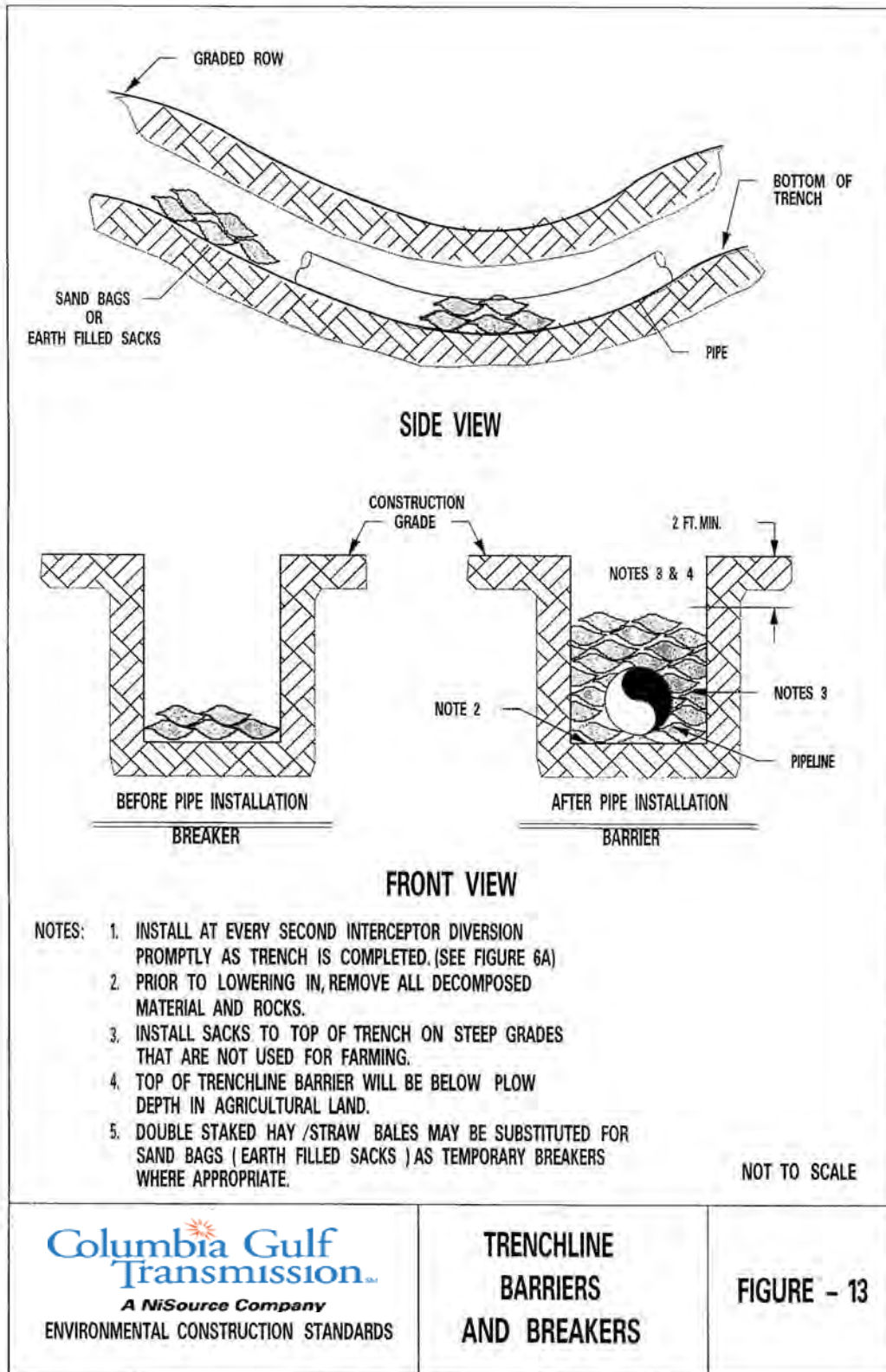



O. Figure 14A – Sediment Trap

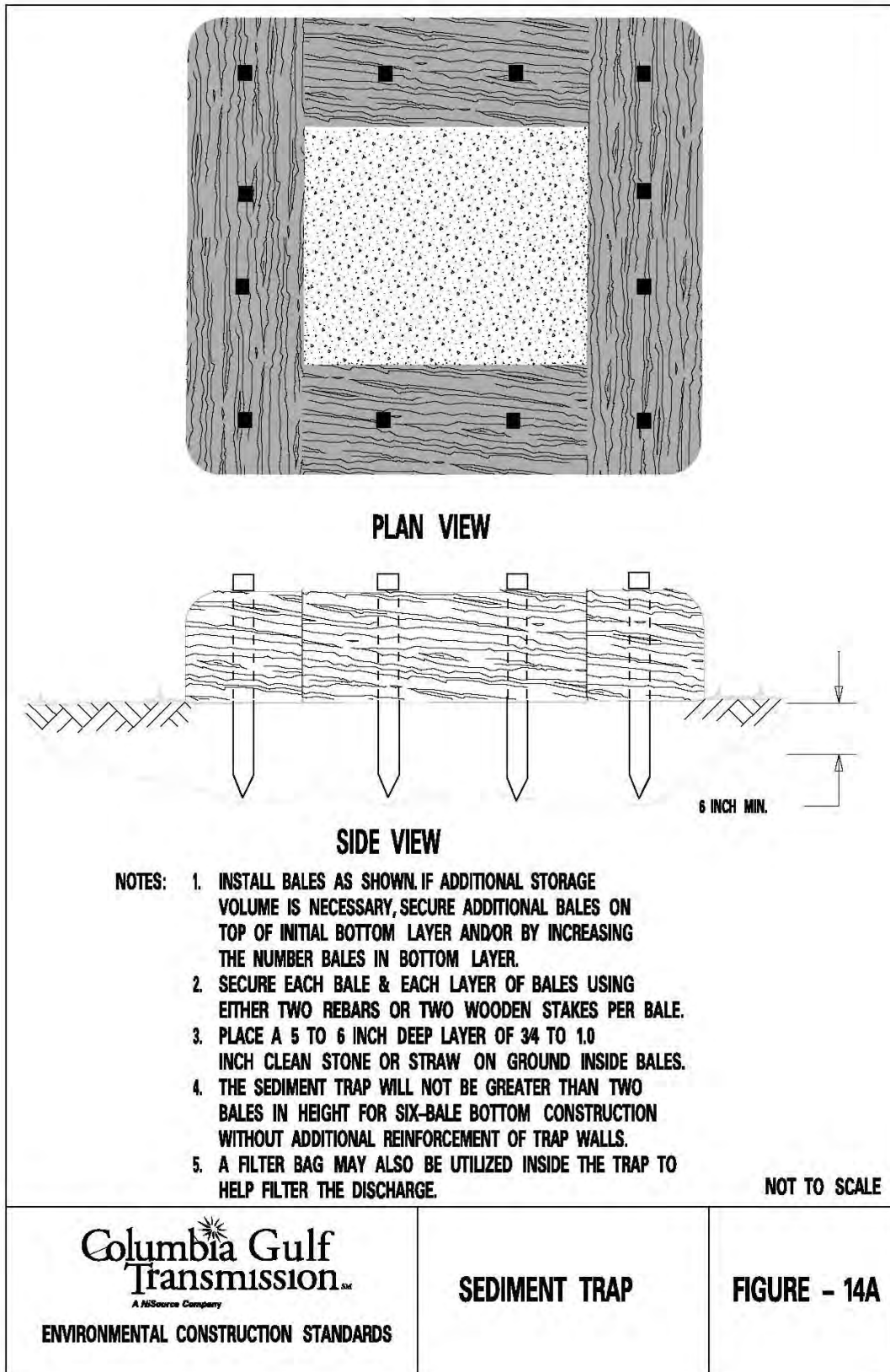

P. Figure 14B – Filter Bag

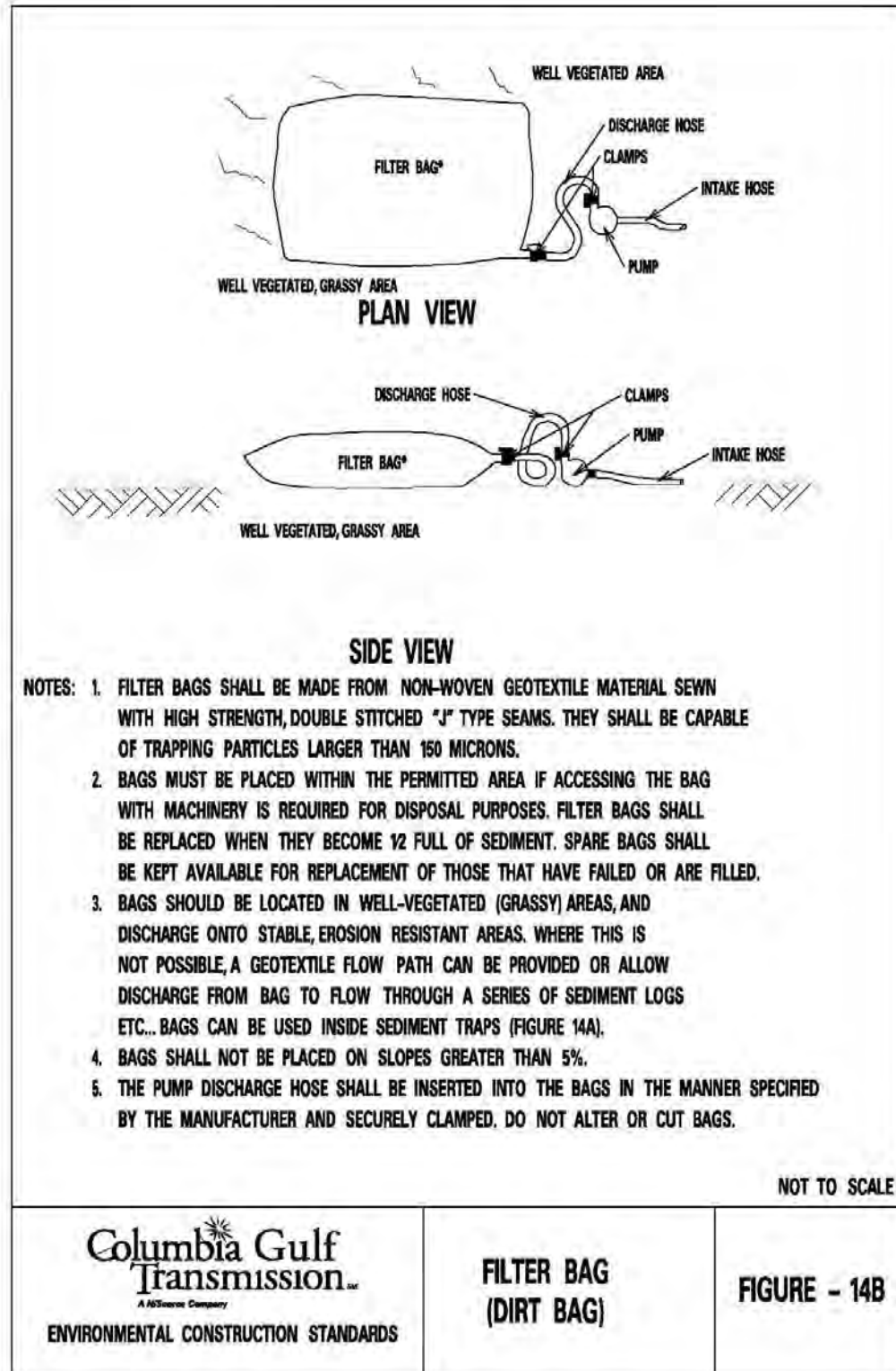

Q. Figure 15 – Field Tile Replacement Methods

R.

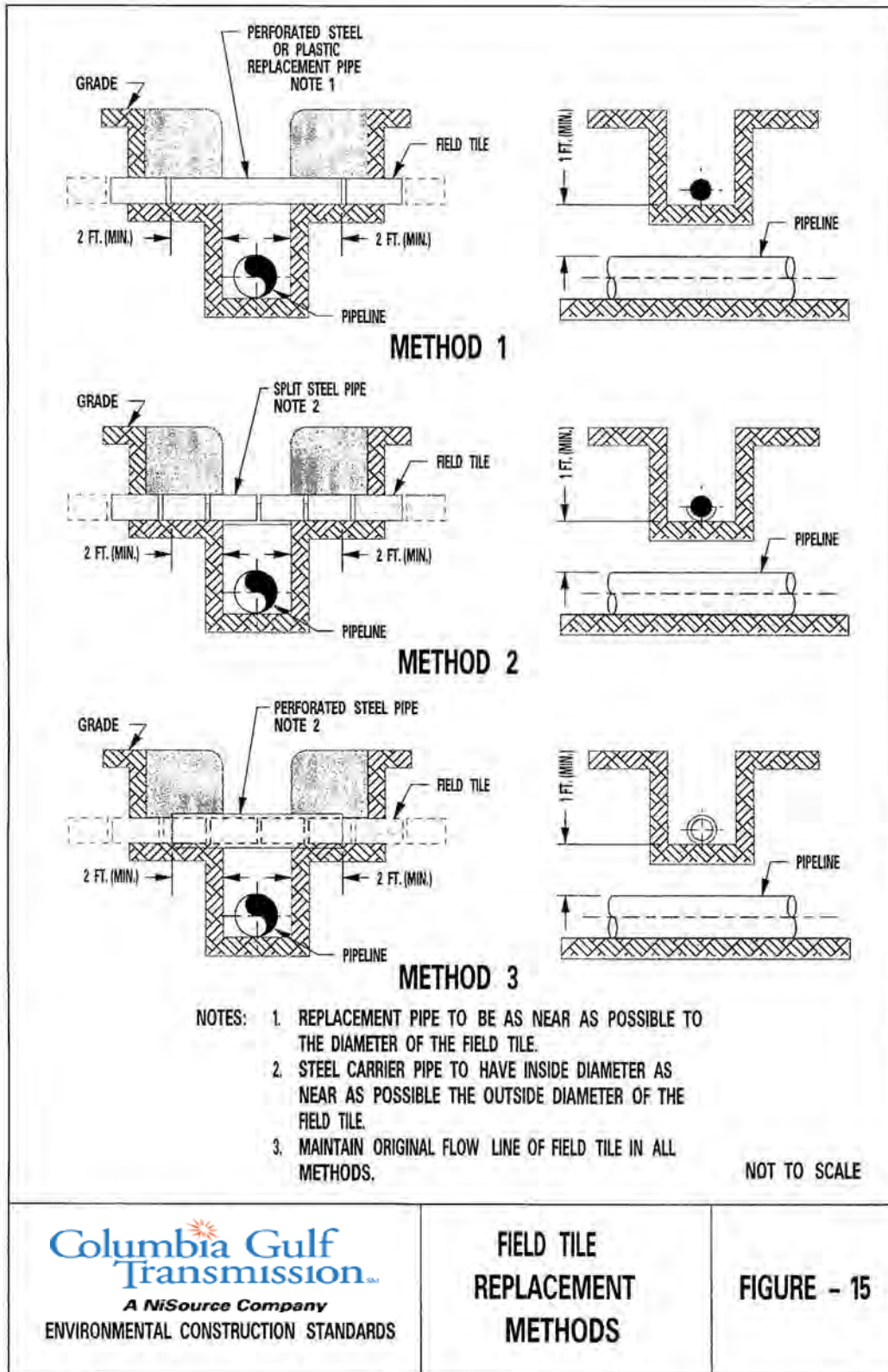

**Figure 16 – Erosion Control Blanket**

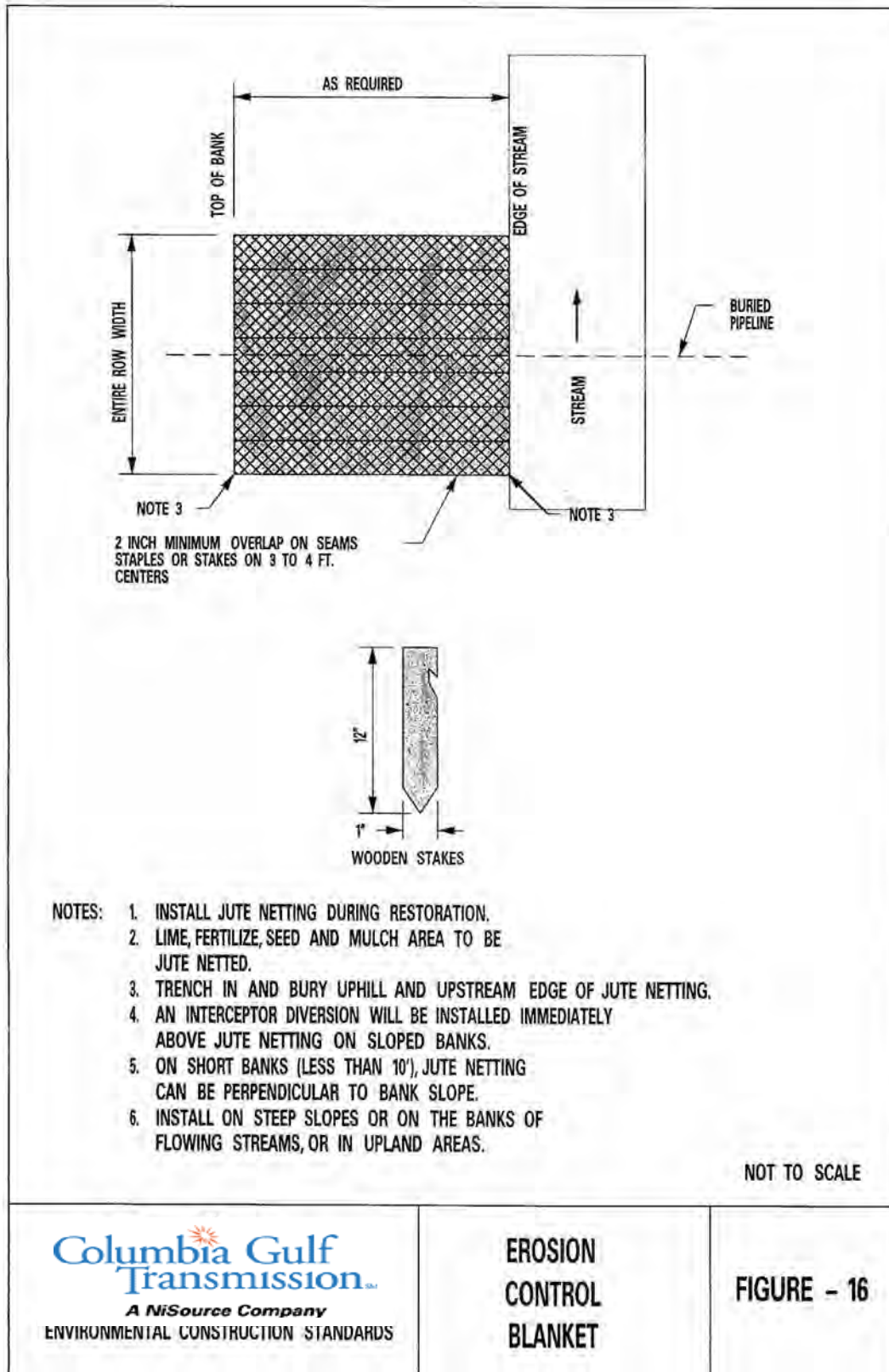

S. Figure 17 – Typical Stream Crossing Intermittent Streams

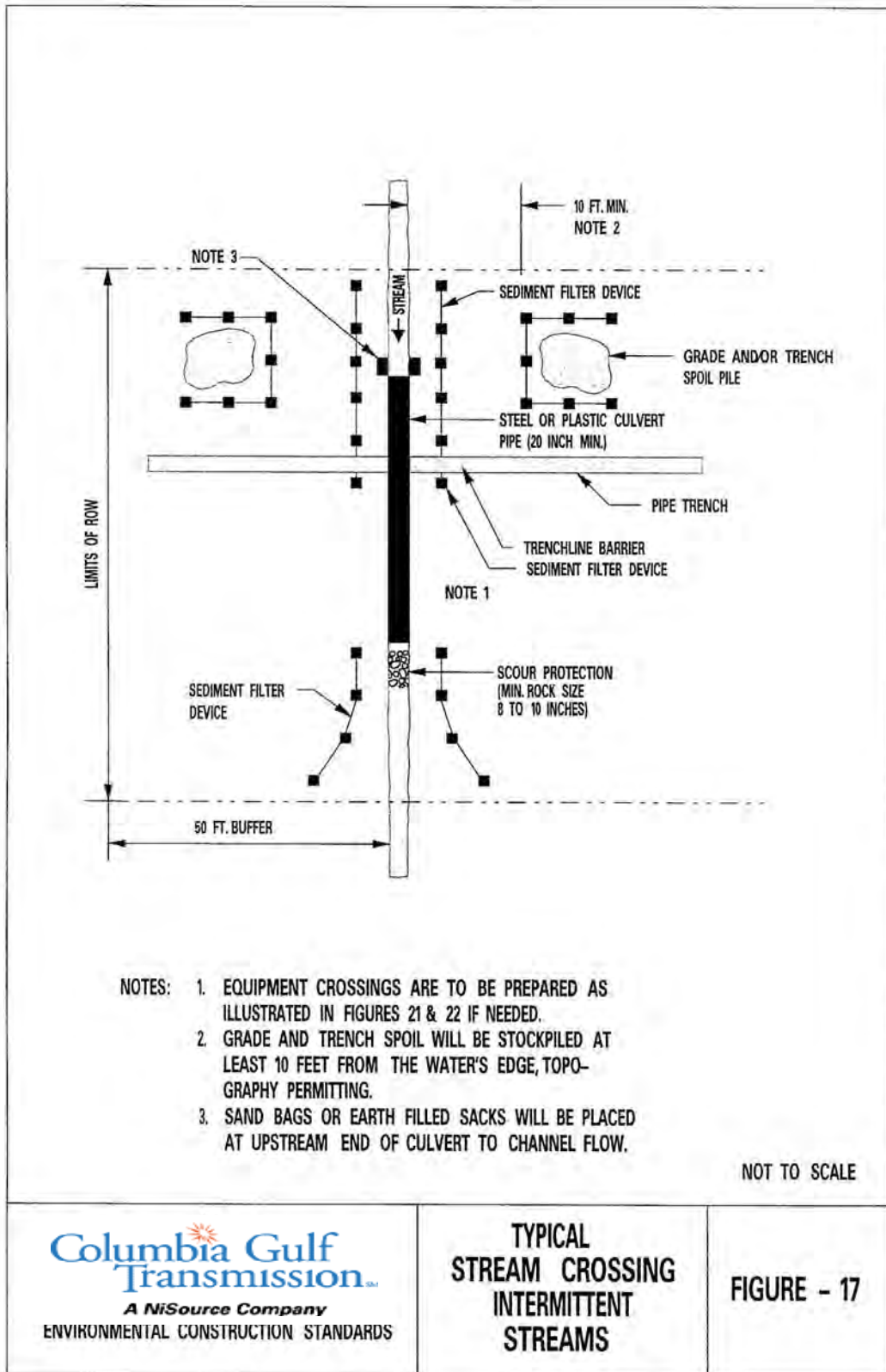

T. Figure 18 – Typical Stream Crossing Dry-Ditch

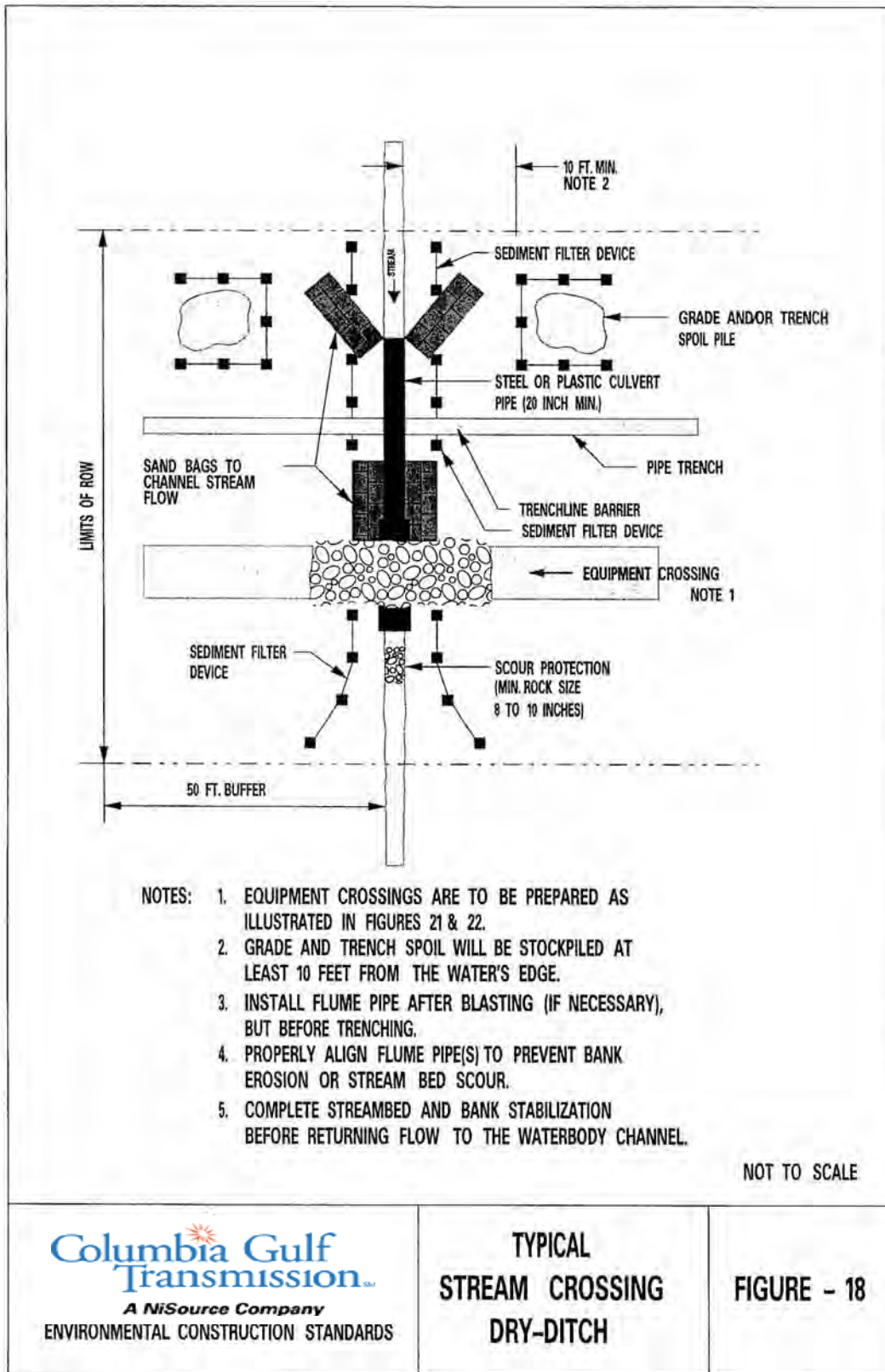

**Columbia Gulf Transmission**  
 A NiSource Company  
 ENVIRONMENTAL CONSTRUCTION STANDARDS

**TYPICAL  
 STREAM CROSSING  
 DRY-DITCH**

**FIGURE - 18**

U. Figure 19 – Typical Stream Crossing Dam and Pump

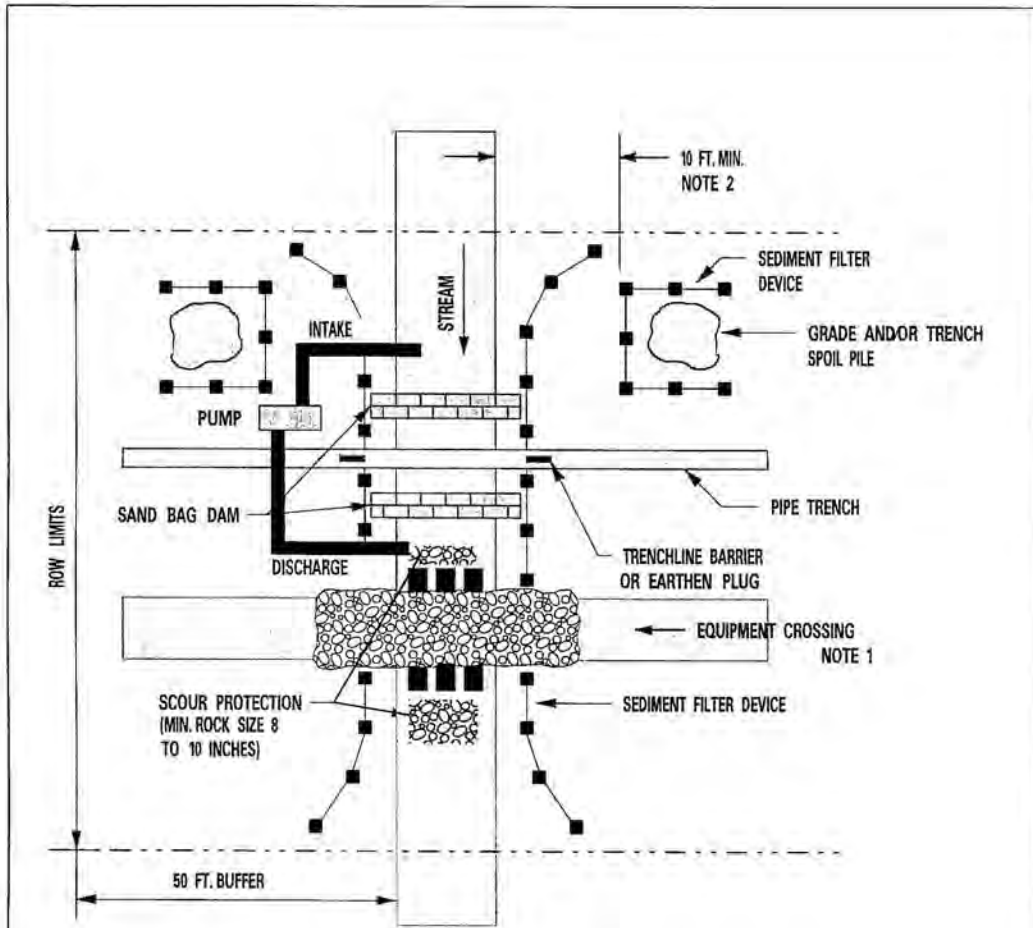

- NOTES:
1. EQUIPMENT CROSSINGS ARE TO BE INSTALLED AS ILLUSTRATED IN FIGURES 21 OR 22.
  2. GRADE AND TRENCH SPOIL WILL BE STOCKPILED AT LEAST 10 FEET FROM THE WATERS' EDGE, TOPOGRAPHY PERMITTING.
  3. PUMP INTAKES WILL BE SCREENED. PREVENT STREAMBED SCOUR AT DISCHARGE.
  4. SUFFICIENT PUMP CAPACITY WILL BE USED TO MAINTAIN STREAM FLOW AT ALL TIMES UNTIL BACKFILL AND REMOVAL OF SANDBAG DAM.
  5. BACKUP PUMPS (AS SAME NUMBER AND CAPACITY AS ACTIVE PUMPS ) WILL BE READILY AVAILABLE IN WORKING CONDITION ON SITE AT CROSSING.
  6. CONSTRUCT DAMS WITH MATERIAL THAT PREVENT SEDIMENT AND OTHER POLLUTANTS FROM ENTERING THE WATERBODY.
  7. MONITOR THE DAM AND PUMPS TO ENSURE PROPER OPERATIONS THROUGHOUT THE WATERBODY CROSSING.

NOT TO SCALE

<p><b>Columbia Gulf Transmission</b>  <i>A NiSource Company</i>          ENVIRONMENTAL CONSTRUCTION STANDARDS</p>	<p><b>TYPICAL          STREAM CROSSING          DAM AND PUMP</b></p>	<p><b>FIGURE - 19</b></p>
---	--	---------------------------

V. Figure 20 – Typical Stream Crossing Wet-Ditch

W.

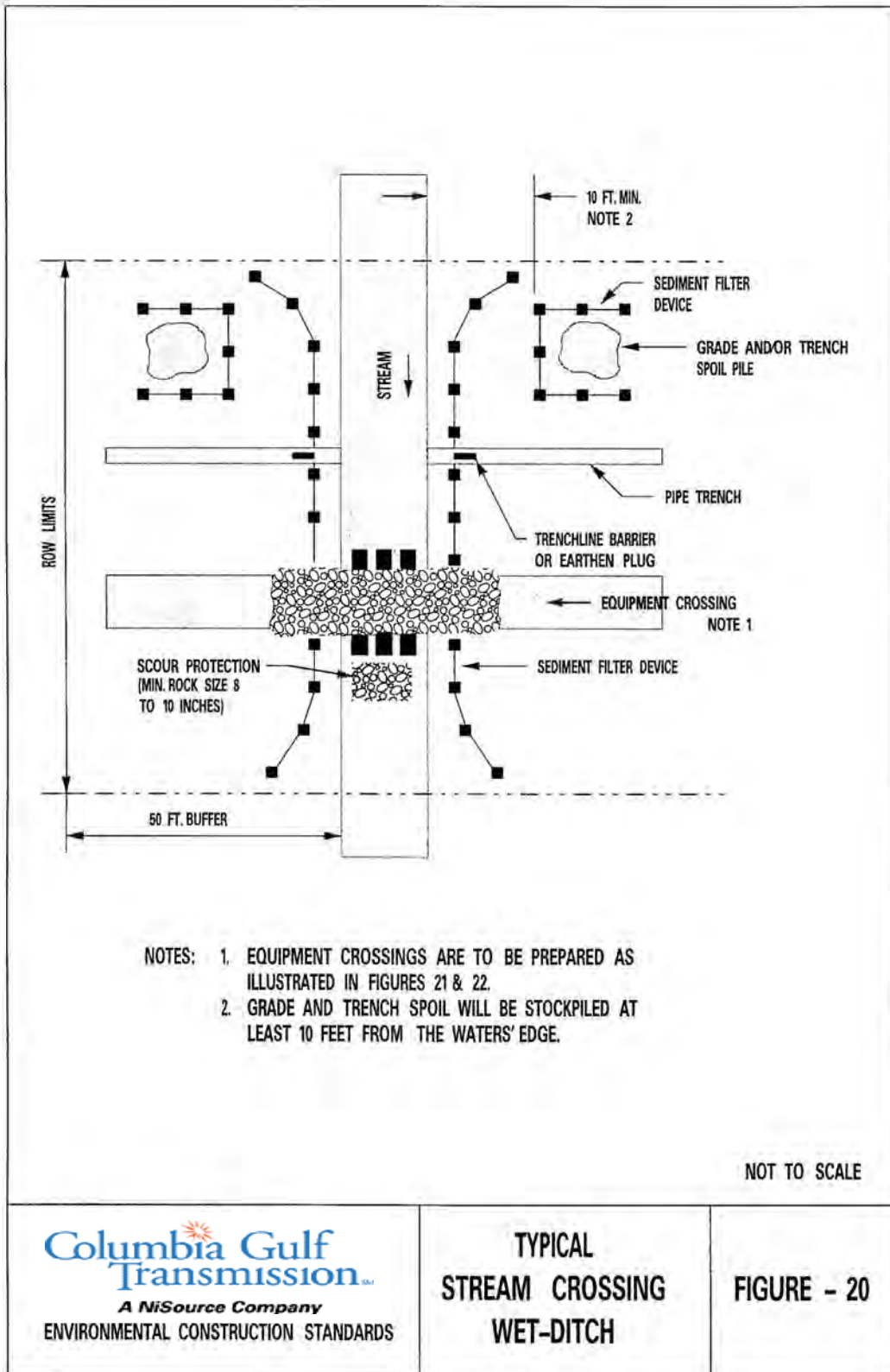
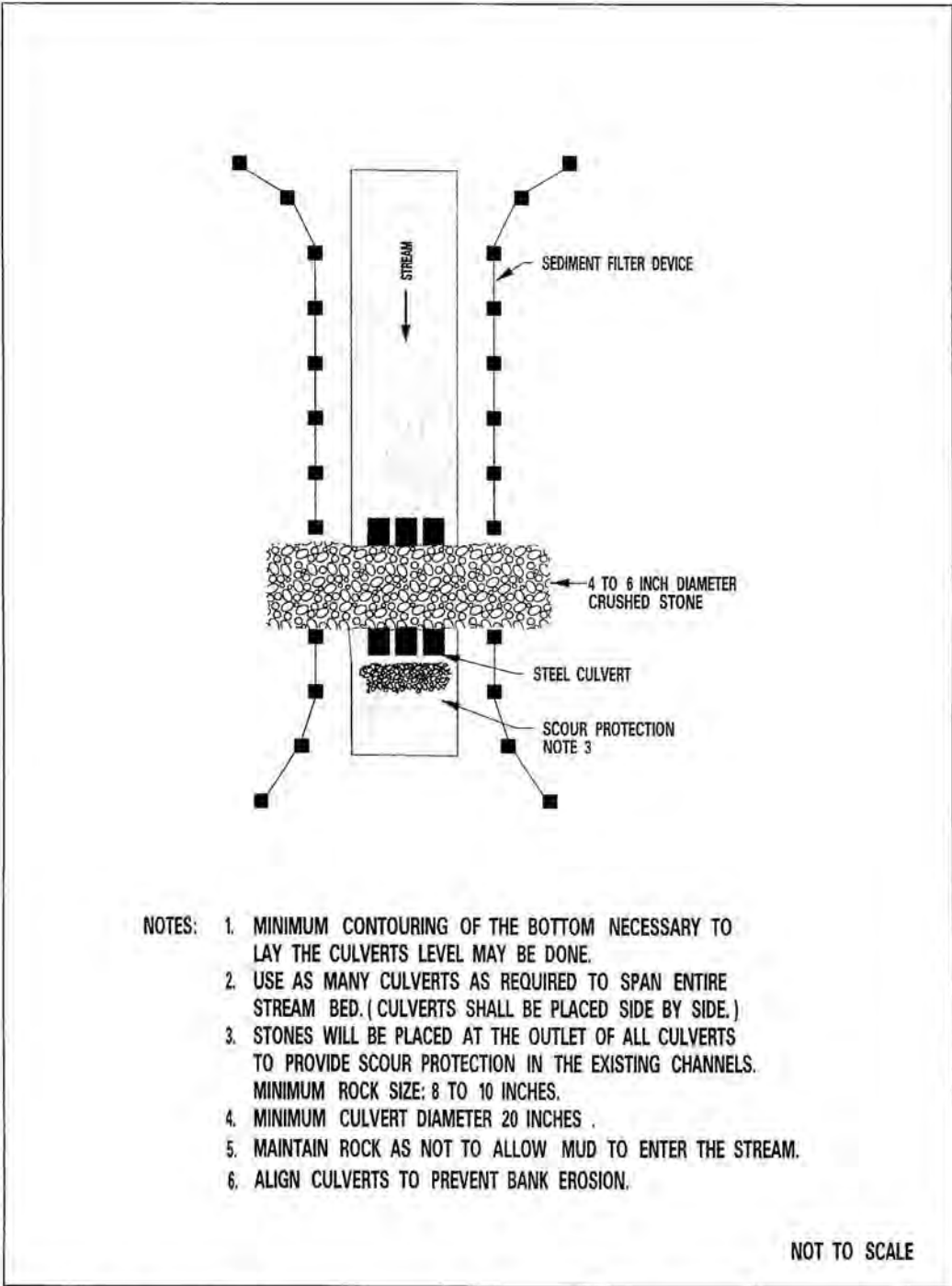



Figure 21 – Temporary Equipment Crossing Culvert and Stone



- NOTES:
1. MINIMUM CONTOURING OF THE BOTTOM NECESSARY TO LAY THE CULVERTS LEVEL MAY BE DONE.
  2. USE AS MANY CULVERTS AS REQUIRED TO SPAN ENTIRE STREAM BED. (CULVERTS SHALL BE PLACED SIDE BY SIDE.)
  3. STONES WILL BE PLACED AT THE OUTLET OF ALL CULVERTS TO PROVIDE SCOUR PROTECTION IN THE EXISTING CHANNELS. MINIMUM ROCK SIZE: 8 TO 10 INCHES.
  4. MINIMUM CULVERT DIAMETER 20 INCHES .
  5. MAINTAIN ROCK AS NOT TO ALLOW MUD TO ENTER THE STREAM.
  6. ALIGN CULVERTS TO PREVENT BANK EROSION.

NOT TO SCALE

<p><b>Columbia Gulf Transmission</b>  <i>A NiSource Company</i>                  ENVIRONMENTAL CONSTRUCTION STANDARDS</p>	<p><b>TEMPORARY                  EQUIPMENT CROSSING                  CULVERT AND STONE</b></p>	<p><b>FIGURE - 21</b></p>
---	--	---------------------------

X. Figure 22 – Temporary Equipment Crossing Equipment Pads

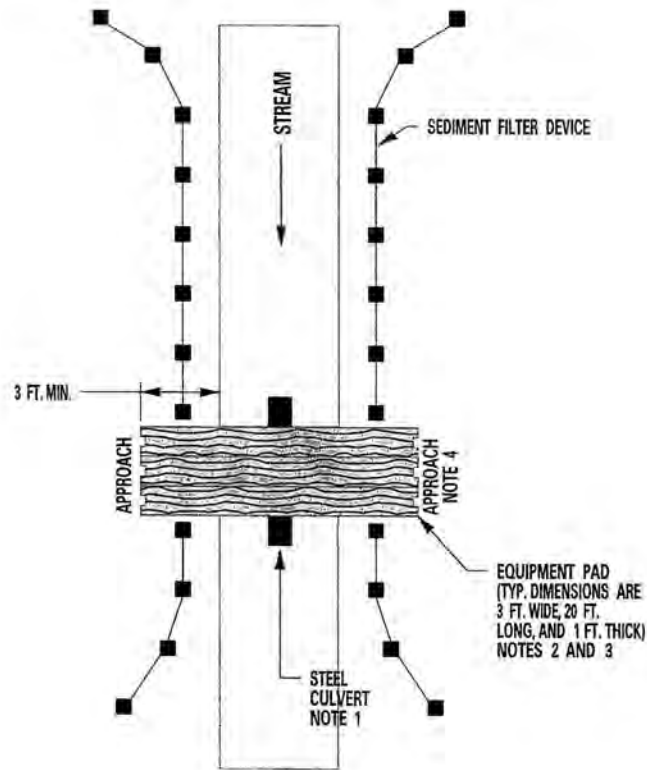

- NOTES:
1. CULVERT PIPE UTILIZED IF ADDITIONAL SUPPORT IS REQUIRED. ALIGN CULVERT TO PREVENT SCOUR OR BANK EROSION.
  2. ADDITIONAL PADS CAN BE PUT SIDE BY SIDE IF EXTRA WIDTH IS REQUIRED.
  3. EQUIPMENT PAD TYPICALLY CONSTRUCTED OF HARD-WOOD; MUST ACCOMMODATE THE LARGEST EQUIPMENT USED.
  4. RAMP APPROACHES CAN EITHER BE GRADED OR DUG INTO GROUND. IF NECESSARY, CRUSHED STONE WILL BE USED TO RAMP UP TO THE EQUIPMENT PADS.
  5. MINIMUM CULVERT DIAMETER 20 INCHES.
  6. MAINTAIN PADS SO AS NOT TO ALLOW MUD TO ENTER THE STREAM

NOT TO SCALE

**Columbia Gulf  
Transmission**  
A NiSource Company  
ENVIRONMENTAL CONSTRUCTION STANDARDS

**TEMPORARY  
EQUIPMENT CROSSING  
EQUIPMENT PADS**

**FIGURE - 22**

Y. Figure 23 – Typical Wetland Crossing

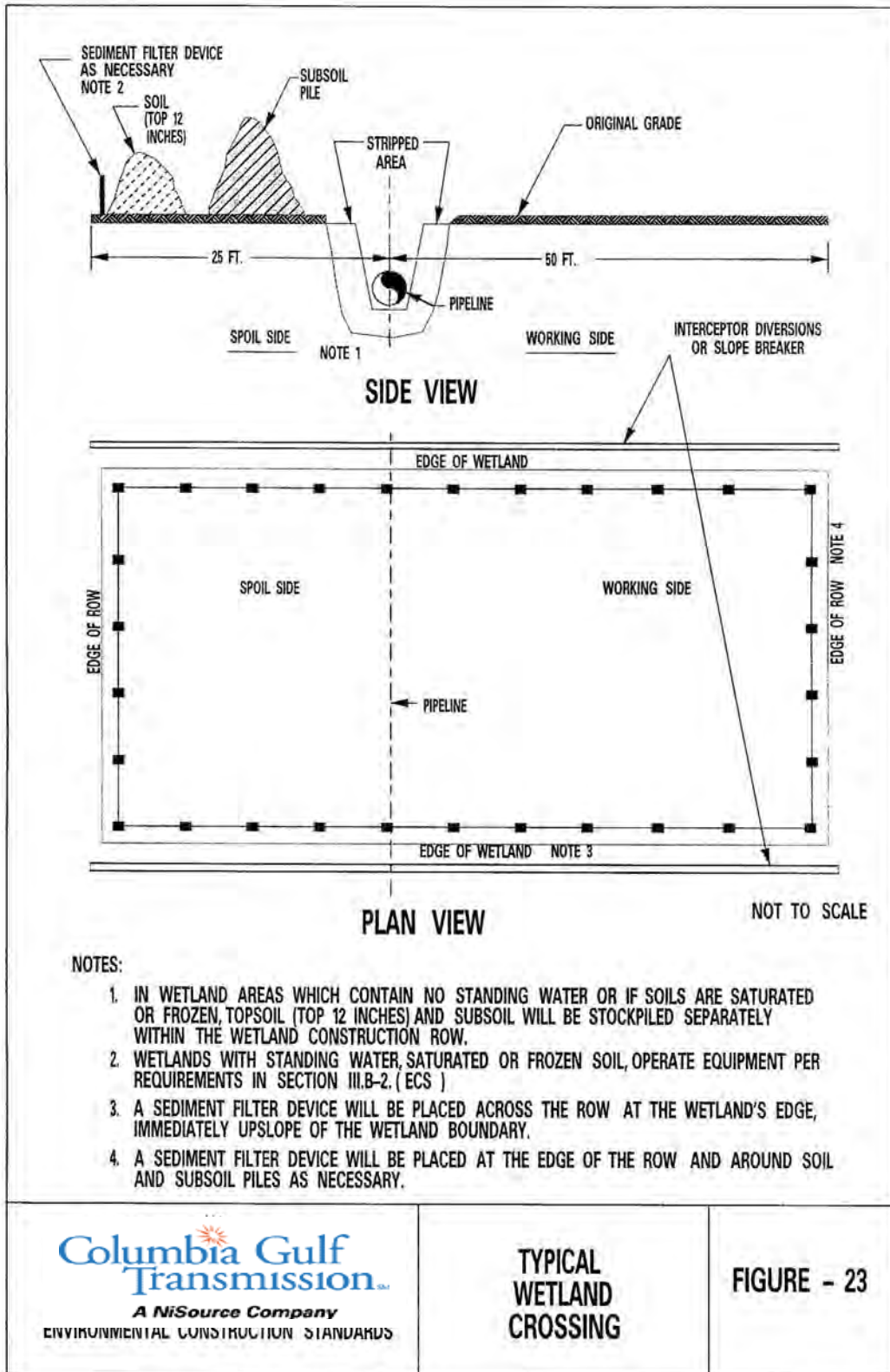

**Columbia Gulf Transmission**  
*A NiSource Company*  
 ENVIRONMENTAL CONSTRUCTION STANDARDS

**TYPICAL WETLAND CROSSING**

**FIGURE - 23**

Z. Figure 24 – ROW Maintenance Perennial Streams

